

Power, Control &
Green Solutions

elsto



Drives & Controls | Stokvis Group 

 **Bonfiglioli**
Tecnoingranaggi

Precision Planetary Gearboxes

TQ
TQF
TQK
TR
MP
LC
LCK
SL
KR

EN

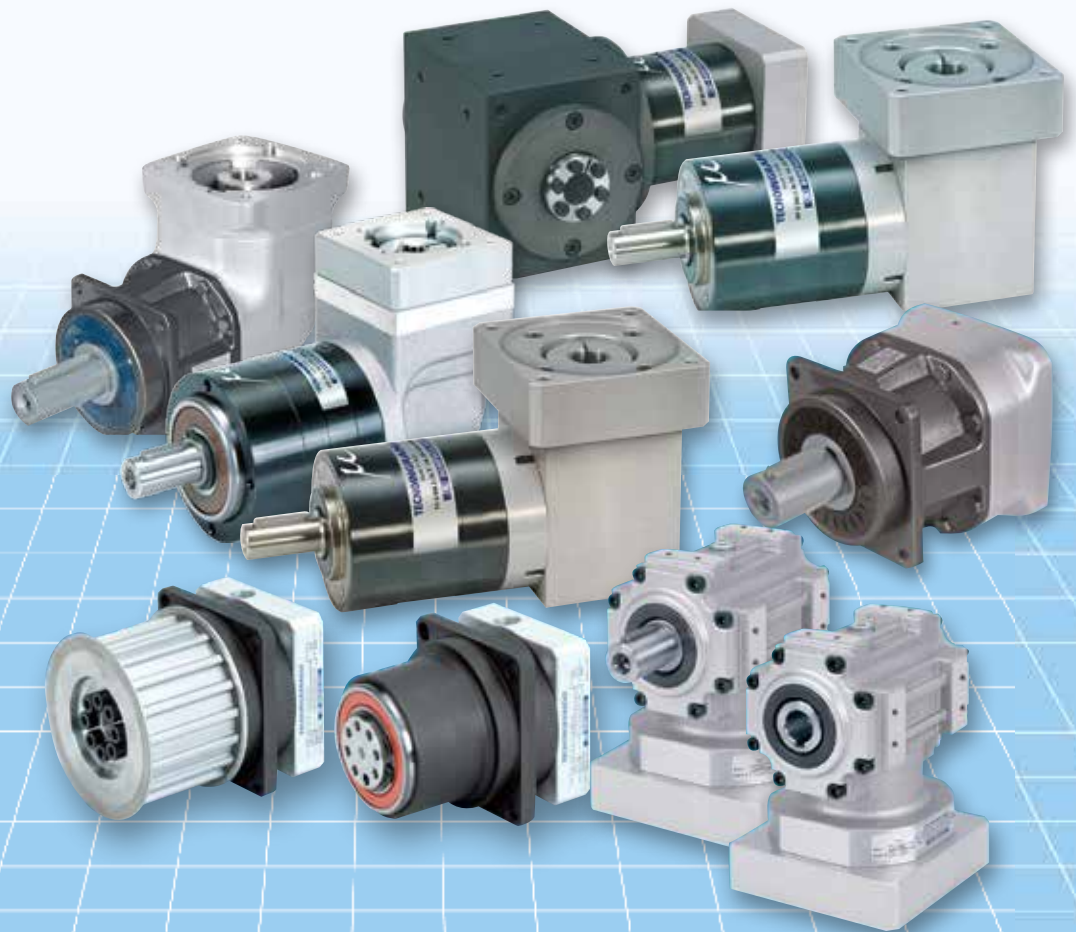

T +31(0)88 7865200
F +31(0)88 7865299
E info@elsto.eu

elsto.eu



ELSTO Drives & Controls is gevestigd in vijf locaties verspreid over Nederland en maakt deel uit van de Stokvis group. Iedere vestiging heeft haar specialisatie en sommige zijn meer dan 100 jaar actief op het gebied van aandrijftechniek. In de loop van de jaren heeft Elsto een compleet programma ontwikkeld die verder gaat dan alleen import en verkoop van aandrijfcomponenten. Meer dan de helft van onze vakbekwame medewerkers is bezig met het realiseren van aandrijfoplossingen volgens klantspecificatie. Bij Elsto stopt de service niet als de aandrijvingen geleverd zijn. Voor de after-sales staat een compleet MRO programma klaar.

Drives

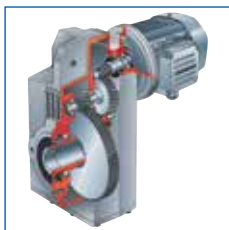

Het elektro-mechanische programma van ELSTO is voor een groot deel gebaseerd op het assortiment van Bonfiglioli Riduttori. Dit programma bestaat uit tandwielreductoren, wormwielreductoren, heavy duty reductoren, planetaire reductoren en motoren. Naast het motorreductoren programma van Bonfiglioli Riduttori voert ELSTO tal van andere gerenommeerde merken in haar programma op het gebied van motoren, lineaire aandrijvingen, koppelingen en overige aandrijfcomponenten. ELSTO beschikt over een kleine 20.000m² magazijnoppervlakte en de meeste van de 150.000 artikelen zijn uit voorraad leverbaar. Leverbetrouwbaarheid en kwaliteit zijn kernwaarden van ons bedrijf.

Controls



Door de opkomst van elektronisch bestuurd aandrijvingen en de verdere ontwikkelingen op dit gebied is deze vakdiscipline in 2006 ondergebracht in een eigen bedrijfsfaciliteit. Hierin worden complete besturingsoplossingen ontworpen, geproduceerd, en (op locatie) in bedrijf gesteld. De projecten variëren van een eenvoudige schakelkast tot een complete besturingsoplossing. Het leveringsprogramma is voor een groot deel gebaseerd op de producten van Bonfiglioli Vectron en Tecnoingranaggi, aangevuld met andere kwalitatief hoogstaande productgroepen op het gebied van besturingen en servoaandrijvingen.

Engineering

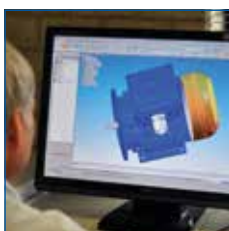

Een groot deel van het succes van ELSTO is te danken aan de creativiteit in het vinden van oplossingen voor aandrijf vraagstukken. In totaal zijn 12 engineers continu bezig met het creëren en uitwerken van maatwerk aandrijvingen voor klanten of eigen productontwikkelingen. Daarnaast staat een groot aantal productspecialisten en projectleiders voor u klaar voor het uitvoeren van grote projecten of consultancy.



De diensten van ELSTO gaan verder dan alleen het leveren van nieuwe producten. ELSTO voert op meerdere locaties in het land reparaties en revisies uit. Hiervoor wordt het bekende totaalconcept Maintenance, Repair en Overhaul (MRO) toegepast. De werkzaamheden variëren van het wikkelen en balanceren van elektromotoren tot het voeren van complete onderhoudsprogramma's in grote productieomgevingen. Dit kan tijdens gepland groot onderhoud zijn maar ook preventief onderhoud behoort tot de dagelijkse werkzaamheden waarbij onder meer trillings- en warmteanalyses worden uitgevoerd. Ook kunt u voor de continuïteit van uw productie rekenen op ELSTO in geval u ongepland storing heeft met als gevolg productiestilstand. Met het beheer van consignatie-voorraden en 24/7 storingsdienst kunt u vertrouwen op snelle en adequate ondersteuning van de ELSTO servicedienst zodat u met een minimum aan stilstandstijd weer verder kunt produceren. ELSTO neemt een unieke positie in Nederland in aangaande ATEX reparatie en onderhoud omdat ELSTO één van de weinige bedrijven is die hiervoor gecertificeerd is.

Specials



Ruim de helft van de medewerkers bij ELSTO is dagelijks bezig met de productie, assemblage, afwerking en installatie (op locatie) van klantspecifieke aandrijvingen. ELSTO voert nagenoeg alle werkzaamheden in eigen huis uit en beschikt onder meer over eigen afdelingen verspaning (conventioneel en CNC), assemblage, spuitrij, testen, revisie en service. Doordat bijna alle werkzaamheden door vakbekwame medewerkers in eigen huis worden uitgevoerd, bent u verzekerd van hoge kwaliteit en snelle doorlooptijd.

System Solutions



Wat is een systeem oplossing

Een systeemoplossing zorgt er voor dat door het slim combineren van aandrijven en besturen een bepaalde taak goed, veilig en efficiënt kan worden uitgevoerd. Bij een geïntegreerde systeemoplossing wordt daarnaast de complete energiecycclus beheerd. Bij al deze oplossingen is het vanzelfsprekend dat ze eenvoudig te bedienen en te onderhouden zijn en gebruik maken van algemeen aanvaarde industriestandaards.

Er worden stationaire en mobiele systeemoplossingen onderscheiden. Bij stationaire oplossingen blijven aandrijfmotor, besturing en transmissie op één plek, terwijl daar omheen het proces plaatsvindt, zoals bij productielijnen, machines of transportsystemen.

Bij een mobiele systeemoplossing bewegen de aandrijfmotor de besturing en transmissie mee met het proces, waarbij vaak de energievoorziening tijdens het gebruik los staat van het vaste stroomnet, zoals bij voer- en vaartuigen en de daarop geïnstalleerde machines of apparaten.

Precision Planetary Gearboxes

INDEX

	Mechatronics - the challenge to build your success	6
	Our expertise from start to finish!	7
	One stop shop for your mechatronic applications	8
	Better performing, efficient & cost effective designs	9
	Energy cost model to allow the servo optimization	10
	A reliable partner for your business	11
	One-stop shop our services	12
	Quality & technology	13
	Our products at a glance	14
	Servo gearheads	16
	Technical information	17
1	General information	18
1.1	Symbols, units and definitions	18
1.2	Selecting the gear unit	20
1.3	Service life of bearings	24
	TQ series	27
2	Features of TQ series	28
2.1	Ordering code	29
2.2	Dimensions and technical specifications	30
	New TQF series	41
3	Features of TQF series	42
3.1	Ordering code	43
3.2	Dimensions and technical specifications	44
	TQK series	55
4	Features of TQK series	56
4.1	Ordering code	57
4.2	Dimensions and technical specification	58
	TR series	69
5	Features of TR series	70
5.1	Ordering code	72
5.1.1	Version and input section	73
5.1.2	Mounting positions	73
5.2	Admissible radial and axial forces for MB version	73
5.3	Dimensions and technical specifications	74
5.3.1	Machine shaft	108
	MP series	109
6	Features of MP series	110
6.1	Ordering code	112
6.1.1	Version and input section	113
6.1.2	Mounting positions	113

Alle rechten voorbehouden. Niets uit deze uitgave mag worden verveelvoudigd, opgeslagen in een geautomatiseerd gegevensbestand, of openbaar gemaakt, in enige vorm of enige wijze, hetzij elektronisch, mechanisch, door fotokopieën, opnamen, of enige andere manier, zonder voorafgaande toestemming van STOKVIS Group te Voorhout. Ondanks alle aan de inhoud van deze catalogus bestede zorg, kan Stokvis Group geen aansprakelijkheid aanvaarden voor eventuele schade die zou kunnen voortvloeien uit enige fout die in deze uitgave zou kunnen voorkomen. Wijzigingen voorbehouden zonder voorafgaande kennisgeving.

Op onze leveringen binnen Nederland zijn van toepassing de algemene leveringsvoorwaarden, dd. december 2011 door de vereniging voor de Metaal- elektrotechnische industrie "F.M.E." ter griffe van de Arrondissementsrechtbank te 's Gravenhage, behoudens de artikelen waarvoor afwijkende en aanvullende bepalingen zijn opgenomen. Op onze leveringen binnen België zijn de leveringsvoorwaarden van Boekholt transmissions van toepassing. Op verzoek sturen wij een afschrift toe.

© Copyright STOKVIS Group, Voorhout - NL

6.2	Admissible radial and axial forces for MB version	113
6.3	Dimensions and technical specifications	114
6.3.1	Machine shaft	148
	LC series	149
7	Features of LC series	150
7.1	Ordering code	151
7.2	Dimensions and technical specifications	152
	LCK series	171
8	Features of LCK series	172
8.1	Ordering code	173
8.2	Dimensions and technical specifications	174
	SL series	193
9	Features of SL series	194
9.1	Ordering code	195
9.2	Dimensions and technical specifications	196
	KR series	209
10	Features of KR series	210
10.1	Versions	210
10.2	Mounting positions	210
10.3	Coordinated shaft rotation	210
10.4	Ordering code	212
10.5	Technical specifications	213
10.6	Mass moment of inertia	214
10.6.1	KR 010...KR 040 with standard ball bearings (SB option)	214
10.6.2	KR 020...KR 040 with taper roller bearings (HB option)	215
10.7	Dimensions	216
10.7.1	Gearbox without motor adapter	224
10.7.2	Machine shaft	225

1988 2002 2004 2008 2009 2010 2013 2014 2015



S-M-BOR-NL-CAFS-001-V01

MECHATRONICS - THE CHALLENGE TO BUILD YOUR SUCCESS

Faster, better and cheaper - this is the new challenge for machine designers!

Increasing demands on the productivity of complex system machines, more flexible machines which run at highest efficiency level are requiring now new intelligent technical solutions that enhance growth tomorrow. Bonfiglioli has implemented a precise and detailed strategy to precisely achieve this objective!

Committed to be your world class partner of smart mechatronic solutions and servosystems, the Industrial Business Unit has established two divisions to serve its reference markets with specialist competence and care:

- Power Transmission Solutions division (PTS)
- Mechatronic Drives & Solutions division (MDS)

Our new Mechatronic Drives & Solutions (MDS) division is born with the mission to improve profitability by acting as a riskless partner and a provider of energy-efficient solutions over the total lifecycle in the field of industrial automation.

- System integration
- Expertise
- Energy saving

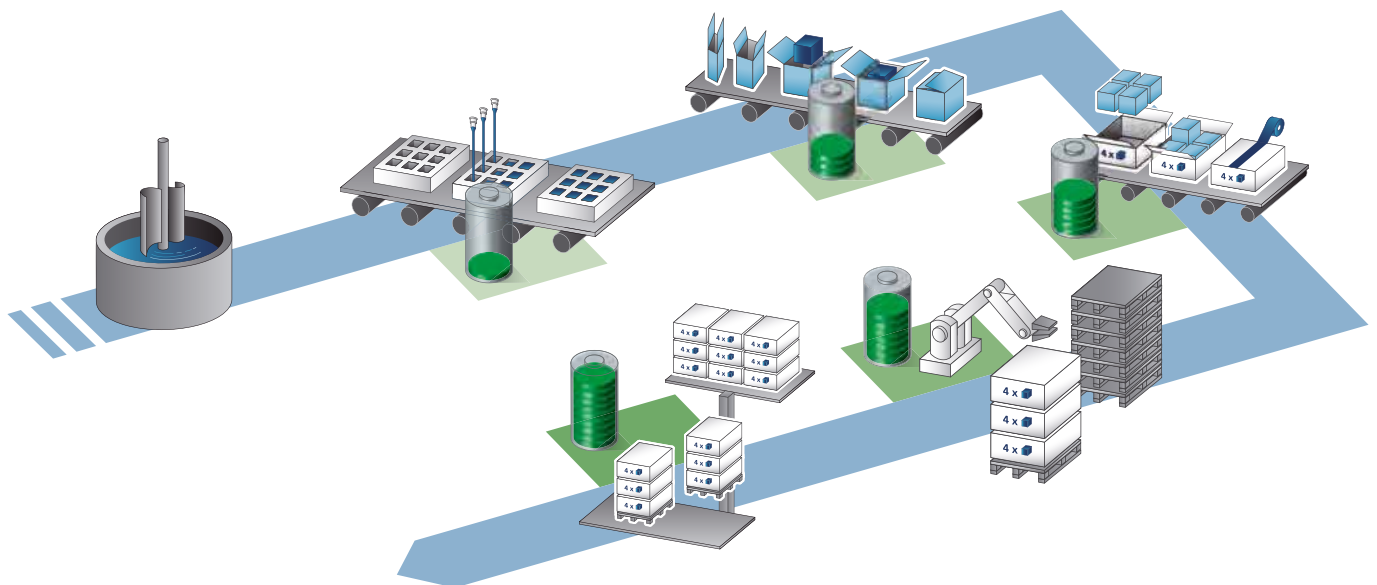

Performance, reliability, low cost, robustness, efficiency and sustainability are absolutely essential.

TRAINING

MECHANICAL &
MECHATRONIC STUDIES

PRODUCT
CUSTOMIZATION

REALIZATION OF PROTOTYPES,
TESTS AND ANALYSIS REPORTS

OUR EXPERTISE FROM START TO FINISH!

Two Centers of Excellence are driving MDS' innovation:

- Bonfiglioli Vectron in Germany, with strong technical, R&D and manufacturing capabilities as regards electronic components, and most notably inverters and servo drives;
- BMR (Bonfiglioli Mechatronic Research), situated in Rovereto (Trento, Italy) who offers a strong R&D capability able to provide innovative new solutions for your specific needs. BMR is a production facility where mechatronic new solutions become reality.

Key to our MDS' success is strongest technical support from our specialists DSC (Drive Service Center team). They accompany you throughout the entire installation's lifecycle, from initial concept idea and design until commissioning in conjunction with our distribution partners

We are close to your needs internationally through its branches which can directly follow the customers using streamlined international teams.



S:\M-BOR-NL-CAFS-001-V01

ON-SITE
ACTIVITIES

START-UP
ASSISTANCE

COMMISSIONING

MAINTENANCE

CUSTOMER
SERVICE

ONE STOP SHOP FOR YOUR MECHATRONIC APPLICATIONS

As a competent technology partner, our engineering specialist are **building together with you tailored and forward looking integrated solutions to meet the individual needs and to deliver mechatronic energy-efficient for your application.**

Our Servopackage is including all the components required for a complete automation solution in one coordinating product package:

- HMI – Bonfiglioli Human Machine Interface
- Programmable controller (ACU / ACT / AGL)
- Highly dynamic servomotors with various feedback devices BMD series
- Precision Planetary Gearboxes (TQ, TQF, TQK, TR, MP, LC, LCK, SL)
- Precision Bevel Gearbox (KR)
- "Ready - to - use" accessories (cables, chokes, filters ecc)



Your benefit:

- Highest Precision & Dynamic
- Strong & Compact
- Highest Radial & Axial Load Capacities
- Highest Tilting Stiffness
- Quiet Operation



Your benefit:

- High Precision & Dynamic
- Frequent Reverse Cycle
- Highest Power Density



Your benefit:

- Energy Saving
- Simplified System Solution
- Wide Constant Torque
- Accurate Four Quadrant Torque & Velocity Control
- Highest Power Density

Complete automation Servo Package from unique supplier!

BETTER PERFORMING, EFFICIENT & COST EFFECTIVE DESIGNS

We are your partner assisting you in sizing, fine tuned optimization and selection of a drive train.

Our attention is focused in designing and manufacturing products for your motion requirements but we also have implemented servo tools that make your design process easier.

We are able to optimize the servopackage avoiding over sizing that increases the initial system cost as well as the ongoing operating cost of a servo system.

Optimized tailored solution and unique supplier.

Req'd	Value
Sequence	6,361 s
Velocity	1,636 °/s
Acceleration	4,002 °/s ²
Deceleration	4,002 °/s ²
Load + Payload	0,0392 kg-m ²
Thrust	-12 Nm
Drive pulley output torque	14,74 Nm
Belt tensile force	421 N
Input torque	15,51 Nm
Rigidity at input	3,567e+13 Nm/rad

ENERGY COST MODEL TO ALLOW THE SERVO OPTIMIZATION

Most modern servosystems are designed to be electrically coupled to share energy, minimize unused or oversized components, and reduce both initial hardware costs as well as operating costs by improved energy efficiency.

As energy prices continue to increase, energy efficiency has become a primary design objective, since energy costs can account for **95% of the life cost of a servo system.**

We have optimized efficiency of entire drive trains by a detailed analysis identifying and assessing potentials for saving energy.

Energy: \$ 129,12/year		Units	Sistema B asse Z	Sistema B asse Y
Output peak power	W		444	304,6
Regen cont power	W		0	18,42
Regen peak power	W		0	256,8
Energy	kWh/year		36,9	41,9
Energy cost	\$/year		36,90	4,19
TI				
Gearbox:				
Output cont power	W		62,2	21,08
Output peak power	W		428	293,5
Regen cont power	W		0	19,03
Regen peak power	W		0	264,9
Energy	kWh/year		20,53	17,96
Energy cost	\$/year		2,05	1,80
Mechanism				
Belt and Pulley				
Output cont power	W		62,2	21,08
Output peak power	W		428	293,5
Regen cont power	W		0	19,03
Regen peak power	W		0	264,9
Energy	kWh/year		54,3	17,96
Energy cost	\$/year		54,33	1,80
Total				
Energy	kWh/year		99,2	236,2
Energy cost	\$/year		99,20	23,62

Which is the energy distribution across the entire cinematic chain / axis?

Which is the potential to optimize the application in terms of energy saving?



A RELIABLE PARTNER FOR YOUR BUSINESS

We bring decades of experience supporting customers across a broad spectrum of industry sectors.

Our industry expertise means we understand your applications: product and requirements must fit and form a solution that match to your application.

Our tailored-solutions always offer to you a complete approach.



Some of the industrial sectors we serve:

- Commercial HVAC
- Machine Tools
- Packaging & Labeling
- Food, Beverage & Tobacco
- Textiles
- Glass working
- Robotics
- Materials Handling
- Rubber & Plastics
- Paper & Paperboard
- Conveyors
- Electronics & Electronic Assembly
- Cranes and Hoists
- Woodworking
- Energy Production
- Renewable Energy
- Material Transformation
- Mining
- Elevators

And many more besides

ONE-STOP SHOP OUR SERVICES

All our solutions enjoy a prompt and reliable technical assistance worldwide.

Specialists with an in-depth knowledge of the market in which they work provide pre-sales, installation, after-sales and user documentation service.

In details, we offer a full range of services tailored to suit our customers wishes and needs.

- Optimal delivery times for your products & very fast deliveries for unplanned requests with urgent procedure.
- Immediate professional technical support able to define customized solutions.
- Fast response time & delivery for your units to replace in case of time-critical situations.

BEFORE
INSTALLATION

AFTER
INSTALLATION



Mechanical & Mechatronic Studies



Product Customization



Realization of Prototypes, Tests & Analysis Reports



Start-Up Assistance



Maintenance



Customer Service

TRAINING

QUALITY & TECHNOLOGY

Product reliability is achieved through a production process geared towards excellence.

Advanced machinery has always been central to our production system.

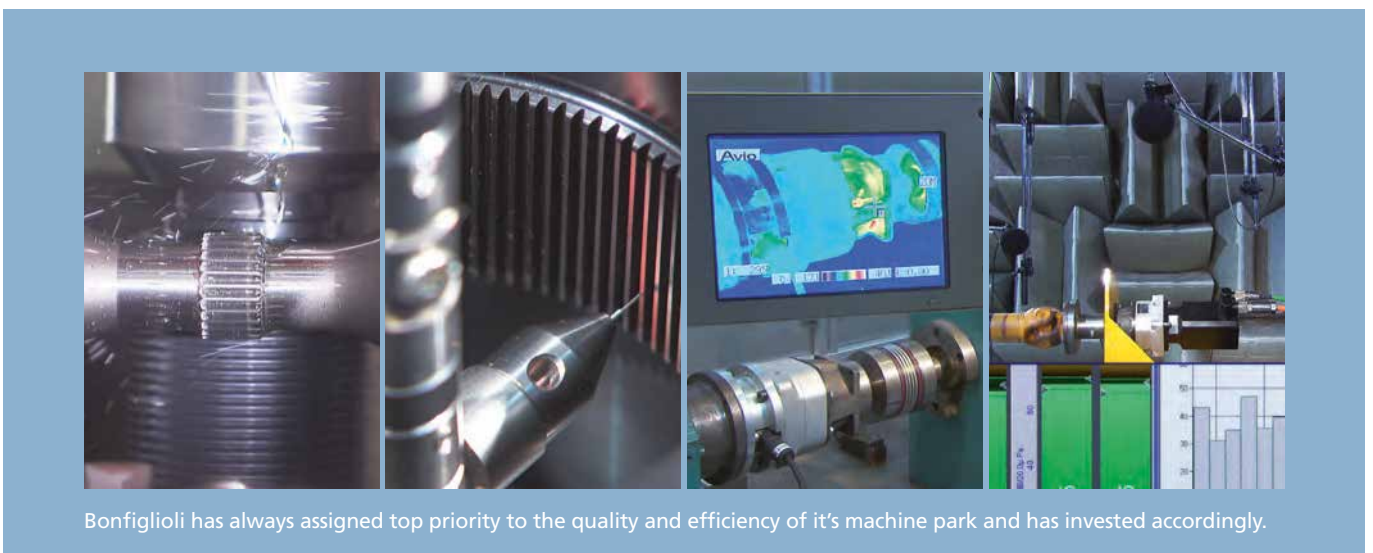
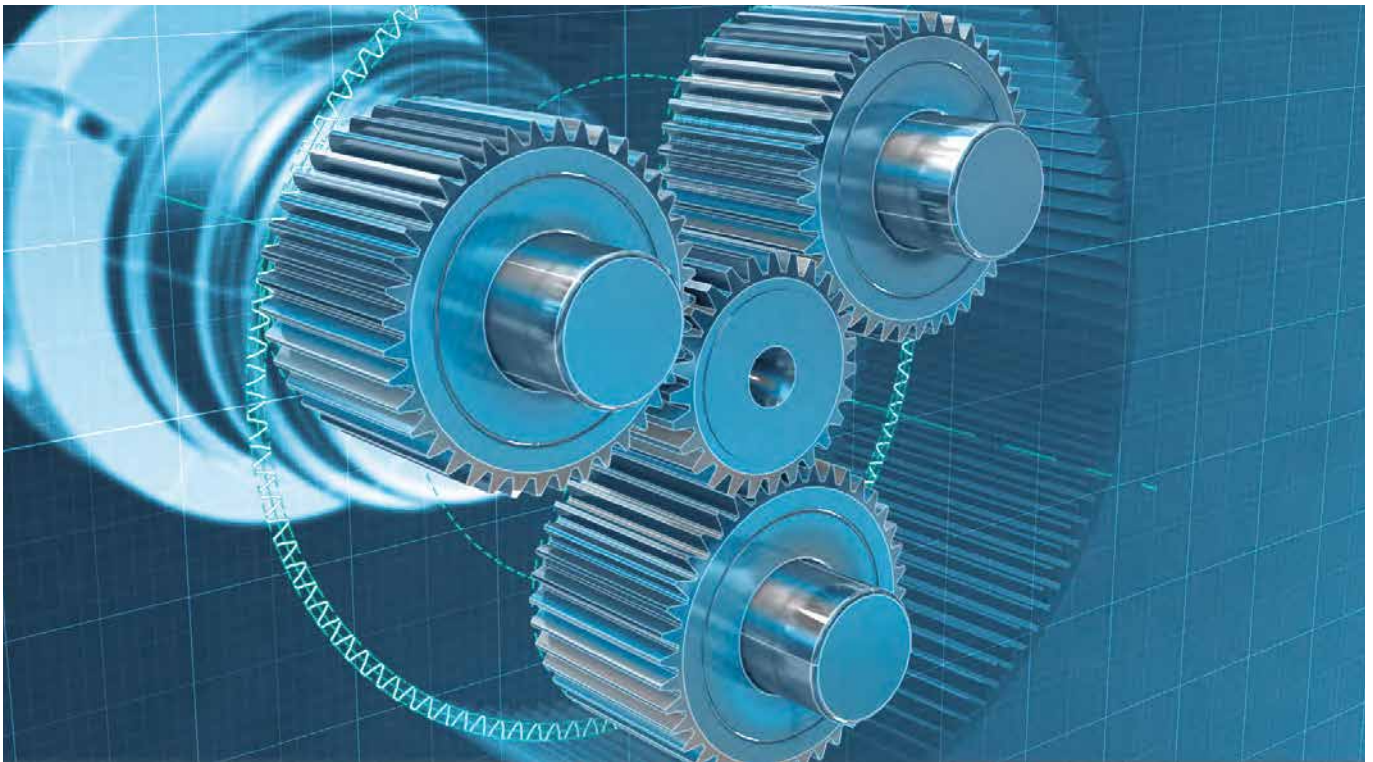

Bonfiglioli has always assigned top priority to the quality and efficiency of its machine park and has invested accordingly.

OUR PRODUCTS AT A GLANCE

		PRODUCT	INLINE	RIGHT ANGLE	PRODUCT LINE-UP	CONFIGURATIONS
HIGH POWER DENSITY	HIGH PERFORMANCE	TQ 	Yes		<ul style="list-style-type: none"> • Highest Precision & Performance • High Speed Applications • Highest Axial & Radial Load Capacities • Quiet Operation • Modular Design for your Needs 	• Solid Shaft
		NEW TQF 	Yes		<ul style="list-style-type: none"> • Strong & Compact • Highest Precision & Dynamic • Highest Axial & Radial Load Capacities • Highest Tilting Stiffness • Quiet Operation 	• Output Flange
		TQK 		Yes	<ul style="list-style-type: none"> • Highest Precision & Performance • High Speed Applications • Highest Axial & Radial Load Capacities • Quiet Operation • Modular Design for your Needs 	• Solid Shaft
	PRECISION	TR 	Yes	Yes	<ul style="list-style-type: none"> • High Performance • High Precision • Modular Design for your Needs 	<ul style="list-style-type: none"> • Solid Shaft • Hollow Bore Shaft • Input Shaft
		MP 	Yes	Yes	<ul style="list-style-type: none"> • High Performance • Medium Precision • Modular Design for your Needs 	<ul style="list-style-type: none"> • Solid Shaft • Hollow Bore Shaft • Input Shaft
	FLEXIBILITY	LC 	Yes		<ul style="list-style-type: none"> • Flexible • Economic Precision • New High Torque Option Available 	<ul style="list-style-type: none"> • Solid Shaft • Input Shaft
		LCK 		Yes	<ul style="list-style-type: none"> • Flexible • Economic Precision • New High Torque Option Available 	<ul style="list-style-type: none"> • Solid Shaft • Input Shaft
		SL 	Yes		<ul style="list-style-type: none"> • Dynamic Belt Application • Compactness • Economic Precision • New High Torque Option Available 	• Solid Shaft
		KR 		Yes	Precision, Dynamics & Compactness at Unbeatable Price	<ul style="list-style-type: none"> • Solid Shaft • Flange • Shrink Disk

S-M-BOR-NL-CAFS-001-V01

MAX. NOM. TORQUE MAX. ACC. TORQUE	RATIO i	TORQUE DENSITY	TORSIONAL STIFFNESS	BACKLASH	CONFIGURATIONS
[Nm]	[-]			[arcmin]	
800 1200	3-100	●●●●●	●●●●	STANDARD ≤ 4-6 LOW ≤ 2-4	●●●●●
800 1200	4-100	●●●●●	●●●●●	STANDARD ≤ 5-7 LOW ≤ 3-5	●●●●●
800 1200	6-200	●●●●●	●●●●	STANDARD ≤ 5-7 LOW ≤ 4-6	●●●●●
1000 1200	3-1000	●●●	●●●	STANDARD ≤ 5-7 LOW ≤ 3-5	●●●
1000 1200	3-1000	●●●	●●●	STANDARD ≤ 15-17 LOW ≤ 10-12	●●●
450 700	3-100	●●●	●●●	STANDARD ≤ 12-15 LOW ≤ 6-8	●●●
450 700	6-100	●●●	●●●	STANDARD ≤ 6-8	●●●
155 300	3-100	●●●	●●●	STANDARD ≤ 12 LOW ≤ 6	●●●
120 170	1-5	●	●	STANDARD ≤ 8	●

S-M-BOR-NL-CAFS-001-V01

SERVO GEARHEADS

Motion applications require the use of planetary gearboxes to adapt speeds and torques, while ensuring precision demanded by the application.

We have chosen to use planetary precision gearboxes with BMD range of permanent magnet synchronous motors.

These gearheads combined with powerful drive electronics are designed for servo applications requiring highest standards in terms of dynamics, precision, robustness, durability and long term operation.

An important requirement for automation applications is high torque capability in a compact and light package. This high torque density requirement (a high torque/volume or torque/weight ratio) is important for automation applications with changing high dynamic loads in order to avoid additional system inertia.

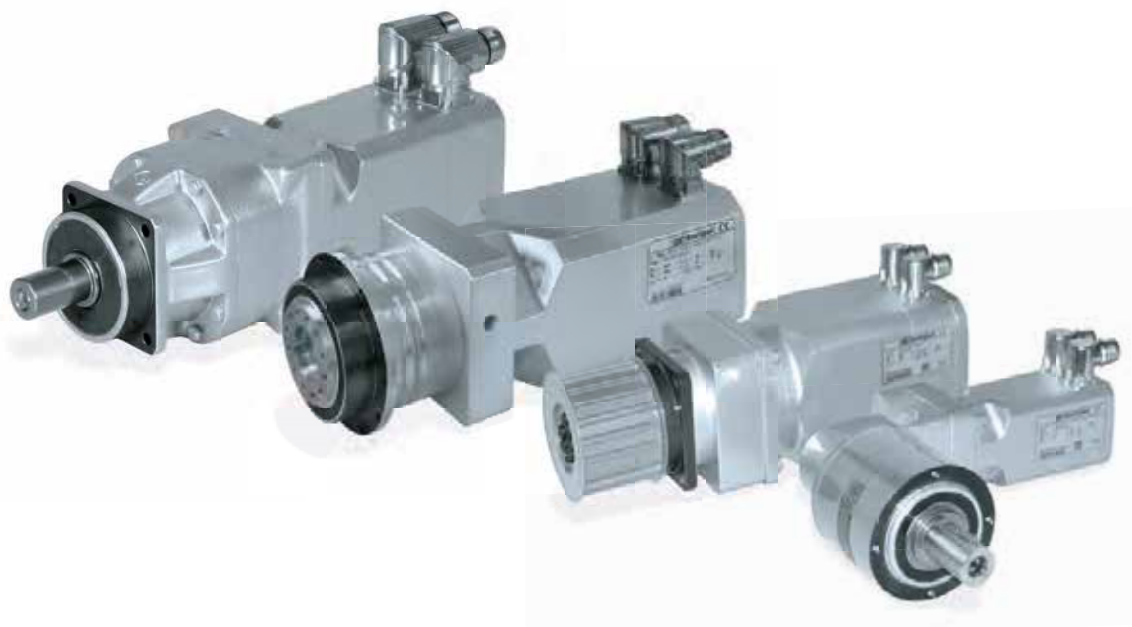

TECHNICAL INFORMATION

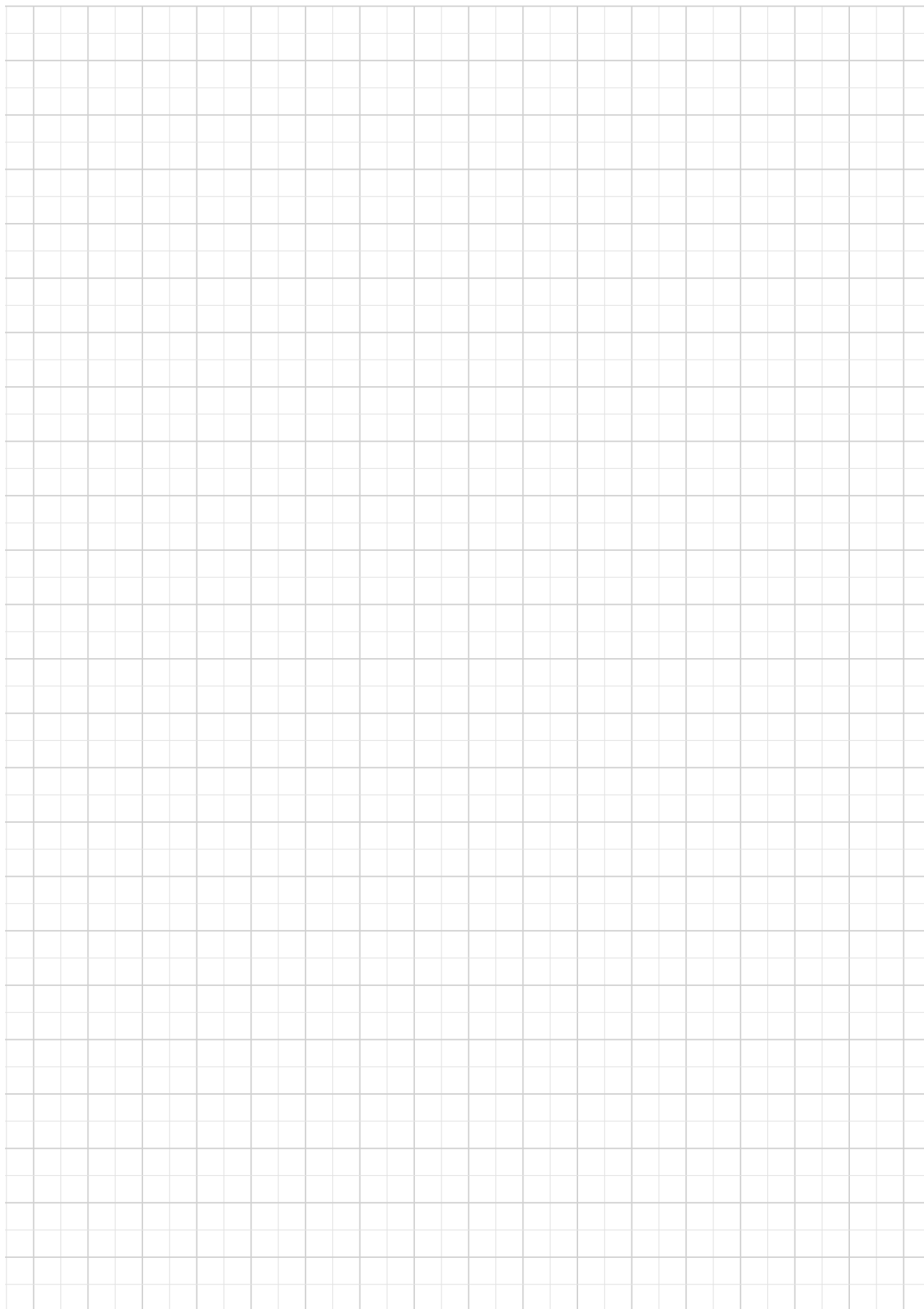

S-M-BOR-NL-CAFS-001-V01

1 GENERAL INFORMATION

1.1 SYMBOLS, UNITS AND DEFINITIONS

Values depending on the **APPLICATION**

term	u.m.	definition
A₂	[N]	Axial force on output shaft
A₂ EQU	[N]	Equivalent axial force applying on output shaft
A₂ MAX	[N]	Maximum axial force applying on output shaft
R₂	[N]	Radial force on output shaft
R₂ EQU	[N]	Equivalent radial force applying on output shaft
R₂ MAX	[N]	Maximum radial force applying on output shaft
ED	[s]	Duration of the duty (without brake)
ED%	[%]	Cyclic duration factor
L_{10h} TARGET	[h]	Output shaft bearings' desired basic rating life
M₁ PEAK	[Nm]	Maximum input torque (limited by motor control)
M₂(1) ... M₂(n)	[Nm]	Output torque at the times t ₁ ... t _n
M₂ EQU	[Nm]	Equivalent output torque
M₂ MAX	[Nm]	Maximum output torque in case of emergency
M_{T2} EQU	[Nm]	Equivalent tilting moment applying on output shaft
M_{T2} MAX	[Nm]	Maximum permissible tilting moment applying on output shaft
n₁	[min ⁻¹]	Nominal input speed
n₂	[min ⁻¹]	Output speed
n₂(1) ... n₂(n)	[min ⁻¹]	Output speed based on the times t ₁ ... t _n
n₂ EQU	[min ⁻¹]	Equivalent output speed
n₂ MAX	[min ⁻¹]	Maximum output speed
T	[C°]	Ambient temperature
t₁ ... t_n	[s]	Operating time
t_Σ	[s]	Cycle duration including pause
Z	[1/h]	Number of cycles per hour

Values depending on the **GEAR DRIVE SELECTION**

term	u.m.	definition
A_{2/3} max	[N]	Admissible axial force on output shaft
A_{2/3'} max	[N]	Axial force acting simultaneously with radial force
R₁ max	[N]	Admissible radial force at midpoint of input shaft
R_{2/3} max	[N]	Admissible radial force at midpoint of output shaft
C_B	[Nm]	Constant for bearing's lifetime calculation
C_t	$\left[\frac{\text{Nm}}{\text{arcmin}} \right]$	Torsional stiffness
f	—	Factor ratio between axial and radial force
f_n	—	Speed factor
f_z	—	Cycle factor
f_T	—	Temperature adjusting factor
i	—	Gearbox ratio
J_G	[kgcm ²]	Mass moment of inertia of the gearhead
K_n	—	Speed constant
L_{10h}	[h]	Bearings basic rating life
L_Z	[mm]	Factor for bearing lifetime calculation
M_{a 2}	[Nm]	Maximum acceleration output torque
M_{n 2}	[Nm]	Rated output torque
M_{p 2}	[Nm]	Emergency stop output torque. Permitted 1000 times during service life of the gearbox
M_{T2} max	[Nm]	Maximum tilting moment applying on output shaft
n₁ max	[min ⁻¹]	Maximum momentary input speed. The speed the unit can be driven at occasionally and in non-repetitive conditions For duty type S5, it cannot be applied continuously for more than 30 seconds
p	—	Bearing lifetime exponent
η	[%]	Gear efficiency
φ_R	[arcmin]	Reduced backlash is calculated in static conditions and with the application of a torque equal to 2% of the gear unit rated torque
φ_S	[arcmin]	Standard backlash is calculated in static conditions and with the application of a torque equal to 2% of the gear unit rated torque

1.2 SELECTING THE GEAR UNIT

(a)	Ratio	i	—	$i = \frac{n_1}{n_2}$
(b)	Equivalent output torque	$M_{2\text{ EQU}}$	[Nm]	$M_{2\text{ EQU}} = \sqrt[3]{\frac{ n_{2(1)} \cdot t_1 \cdot M_{2(1)} ^3 + \dots + n_{2(n)} \cdot t_n \cdot M_{2(n)} ^3}{ n_{2(1)} \cdot t_1 + \dots + n_{2(n)} \cdot t_n}}$
(c)	Equivalent output speed	$n_{2\text{ EQU}}$	[min ⁻¹]	$n_{2\text{ EQU}} = \frac{ n_{2(1)} \cdot t_1 + n_{2(2)} \cdot t_2 + \dots + n_{2(n)} \cdot t_n}{t_\Sigma}$
(d)	Speed factor	f_n	—	<p>If $\frac{K_n}{n_{2\text{ EQU}} \cdot i} \geq 1 \Rightarrow f_n = 1$</p> <p>If $\frac{K_n}{n_{2\text{ EQU}} \cdot i} < 1 \Rightarrow f_n = \text{Obtain from diagram}$</p>
(e)	Temperature adjusting factor	f_T	—	
(f)	Cyclic duration factor	ED%	[%]	$ED\% = \frac{ED}{t_\Sigma} \cdot 100$
	Duration of the duty	ED	[s]	$ED = t_1 + t_2 + \dots + t_n$
(g)	Number of cycles per hour	Z	[1/h]	$Z = \frac{3600}{t_\Sigma}$
(h)	Cycle factor*	f_z	—	<p>*For Z>6000 please contact us!</p>
(i)	Maximum input torque	$M_{1\text{ PEAK}}$	[Nm]	<p>a) maximum possible application torque</p> <p>b) limited motor torque by inverter</p> <p>c) maximum motor torque</p>

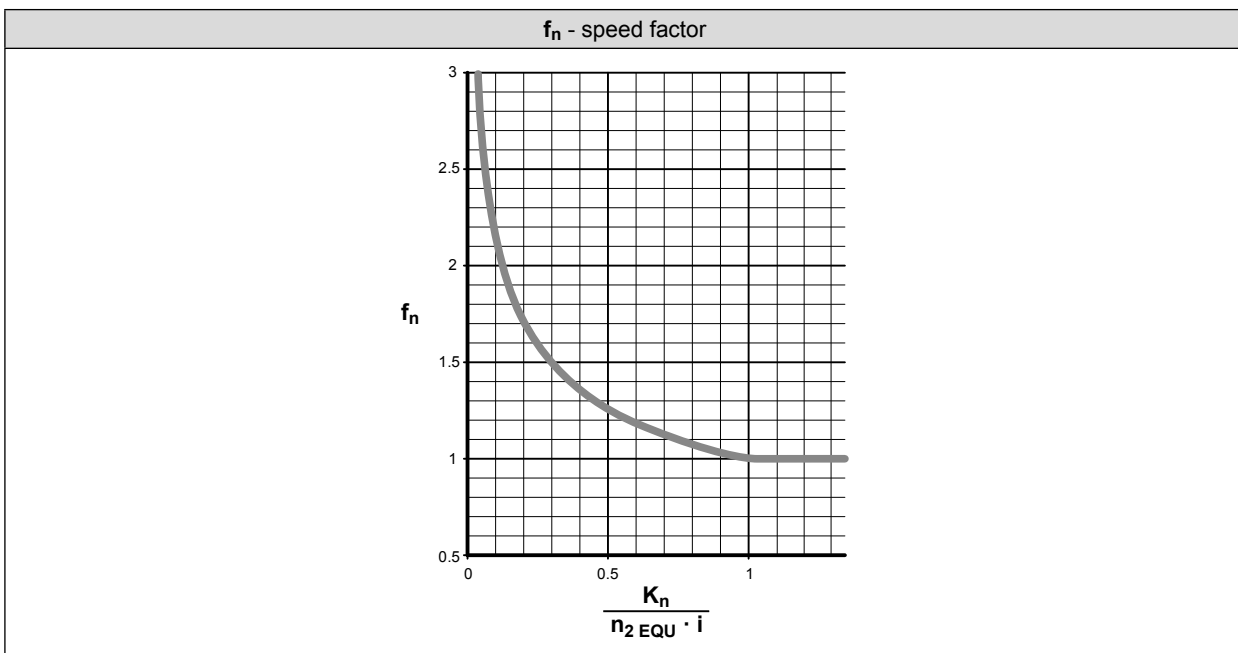

K_n - speed constant

i	TQ 060	TQ 070	TQ 090	TQ 130	TQ 160
3	3500	3100	1050	1800	1100
4	3500	3300	1050	2000	1450
5	3500	3500	1700	2500	1650
7	4000	3500	3000	2800	2500
10	4000	3500	3000	2800	2500
16	4500	3500	3000	2800	2500
20	4500	3500	3000	2800	2500
25	4500	3500	3000	2800	2500
28	4500	3500	3000	2800	2500
35	4500	3500	3000	2800	2500
40	4500	3500	3000	2800	2500
50	4500	3500	3500	3200	2500
70	5000	4500	4000	3500	2500
100	5000	4500	4000	3500	2500

i	TQK 060	TQK 070	TQK 090	TQK 130	TQK 160
6	2400	2400	2000	1600	1600
8	2400	2400	2000	1600	1600
10	2400	2400	2000	1600	1600
14	2400	2400	2000	1600	1600
18	2400	2400	2400	2000	1600
20	2400	2400	2400	1600	1600
24	2400	2400	2400	2000	1600
30	2400	2400	2400	2000	1600
40	2400	2400	2400	2000	1600
50	2400	2400	2400	2000	1600
70	2400	2400	2400	2000	1600
80	2400	2400	2400	2000	1600
100	2400	2400	2400	2000	1600
140	2400	2400	2400	2000	1600
200	2400	2400	2400	2000	1600

i	TR / MP	TR / MP	TR / MP	TR / MP	TR / MP	TR / MP	TR / MP
	053	060	080	105	130	160	190
3	1400	1400	2700	2500	1700	550	1500
4	2000	1600	1500	1600*	500*	350*	1150
5	2300	2050	1750	1850*	600*	350*	1300
6	2300	2500	2500	1050*	150*	150*	1150*
7	3800	3000	2100	1350	400*	300*	1600
9	4000	3300	2900	2500	2100	1600	1500
10	-	4000	4000	3500	3200	1150	2900
12	3300	3300	1500	1500	500	300*	1050
15	3300	3300	1700	1750	600	350*	1200
16	3500	3500	1950	2050	700	450*	1400
20	3500	3500	2450	2550	850	300	1750
25	3500	3500	2800	2900	1000	350	2000
28	4000	4000	3450	3500	1200	450	2450
30	-	4000	4000	3500	3200	3000	1950
35	4000	4000	3950	3500	1350	500	2800
36	4000	3500	3200	1950	550	500	2300
40	-	4000	4000	3500	1700	650	2900
45	4000	-	-	-	-	-	-
48	4000	3500	3100	2800	2300	850	2100
50	-	4000	4000	3500	1950	750	2900
60	3500	-	-	-	-	-	-
64	3500	3500	3100	2800	2750	1000	2100
70	-	4000	4000	3500	2400	900	2900
75	3500	3500	3200	3000	3200	1350	2300
80	4000	3500	3100	2800	2400	1300	2100
81	4000	-	-	-	-	-	-
84	4000	4000	4000	3500	2900	1050	2900
90	-	4000	4000	3500	2850	3000	2900
100	4000	4000	4000	3500	3200	3000	2900
112	3500	-	-	-	-	-	-
120	-	4000	4000	3500	3200	2150	2900
125	4000	3500	3200	3000	2900	1800	2300
140	4000	4000	4000	3500	3200	2050	2900
144	4000	-	-	-	-	-	-
150	-	4000	4000	3500	3200	2200	2900
160	-	4000	4000	3500	3200	2550	2900
175	4000	4000	4000	3500	3200	2550	2900
180	4000	-	-	-	-	-	-
200	-	4000	4000	3500	3200	2900	2900
210	-	4000	4000	3500	3200	2700	2900
216	3500	3500	3200	3000	1900	-	-
225	4000	-	-	-	-	-	-
245	4000	-	-	-	-	-	-
250	-	4000	4000	3500	3200	3000	2900
252	4000	-	-	-	-	-	-
280	-	4000	4000	3500	3200	3000	2900
324	4000	-	-	-	-	-	-
350	-	4000	4000	3500	3200	3000	2900
400	-	4000	4000	3500	3200	3000	2900
405	4000	-	-	-	-	-	-
500	-	4000	4000	3500	3200	3000	2900
567	4000	-	-	-	-	-	-
700	-	4000	4000	3500	3200	3000	2900
729	4000	-	-	-	-	-	-
1000	-	4000	4000	3500	3200	3000	2900

i	TQF 060	TQF 070	TQF 090	TQF 130	TQF 160
3	3500	3100	1050	1800	1100
4	3500	3300	1050	2000	1450
5	3500	3500	1700	2500	1650
7	4000	3500	3000	2800	2500
10	4000	3500	3000	2800	2500
16	4500	3500	3000	2800	2500
20	4500	3500	3000	2800	2500
25	4500	3500	3000	2800	2500
28	4500	3500	3000	2800	2500
35	4500	3500	3000	2800	2500
40	4500	3500	3000	2800	2500
50	4500	3500	3500	3200	2500
70	5000	4500	4000	3500	2500
100	5000	4500	4000	3500	2500

i	LC 050	LC 070 / LC 070P	LC 090 / LC 090P	LC 120 / LC 120P	LC 155 / LC 155P
3	1650	1400	2900 / 3500	2500 / 3500	1350 / 3500
4	2200	1600	2500 / 2000	2100 / 1700	900 / 2200
5	2900	2050	2700 / 1500	2300 / 1500	950 / 800
7	3700	3050	3500 / 1900	3000 / 1900	1250
9	4000	3300	2900 / 3500	2500 / 3500	3000
10	-	4000	4000 / 3500	3500	2500 / 3500
12	3300	3300	2900 / 3500	2500 / 3500	2100 / 3500
15	3300	3500	2900 / 3500	2500 / 3500	2100 / 3500
16	3500	3500	3100	2800	3000
20	3500	3700	3200	3000	3000
25	3500	4000	3200	3000	3000
28	3500	3700	3500	3500	3000
30	-	4000	4000	3500	3000
35	3700	4000	3500	3000	3000
36	4000	-	-	-	-
40	-	4000	4000	3500	3000
45	4000	-	-	-	-
50	-	4000	4000	3500	3000
70	-	4000	4000	3500	3000
81	4000	-	-	-	-
100	-	4000	4000	3500	3000

i	LCK 050	LCK 070 / LCK 070P	LCK 090 / LCK 090P	LCK 120 / LCK 120P	LCK 155 / LCK 155P
6	2400	2400	2400	2000	1600
8	2400	2400	2400	2000	1600
10	2400	2400	2400	2000	1600
14	2400	2400	2400	2000	1600
20	-	2400	2400	2000	1600
24	2400	2400	2400	2000	1600
30	2400	2400	2400	2000	1600
50	2400	2400	2400	2000	1600
70	2400	2400	2400	2000	1600
80	-	2400	2400	2000	1600
90	2400	-	-	-	-
100	-	2400	2400	2000	1600

i	SL 070	SL 090 / SL 090P	SL 120 / SL 120P
3	1400	2900 / 3500	2500 / 3500
4	1600	2500 / 2000	2100 / 1700
5	2050	2700 / 1500	2300 / 1500
7	3050	3500 / 1900	3000 / 1900
9	3300	2900 / 3500	2500 / 3500
10	4000	4000 / 3500	3500
12	3300	2900 / 3500	2500 / 3500
15	3500	2900 / 3500	2500 / 3500
16	3500	3100	2800
20	3700	3200	3000
25	4000	3200	3000
28	3700	3500	3000
30	4000	4000	3500
35	4000	3500	3000
40	4000	4000	3500
50	4000	4000	3500
70	4000	4000	3500
100	4000	4000	3500

i	KR 010	KR 020	KR 030	KR 040
1	1200	1200	1000	800
2	2400	2400	2000	1600
3	3000	3000	2800	2500

In case of S1 duty the values marked with * reduce the average service life of bearings.

Load diagram

— M_2 : Output torque

Speed diagram

— n_2 : Output speed

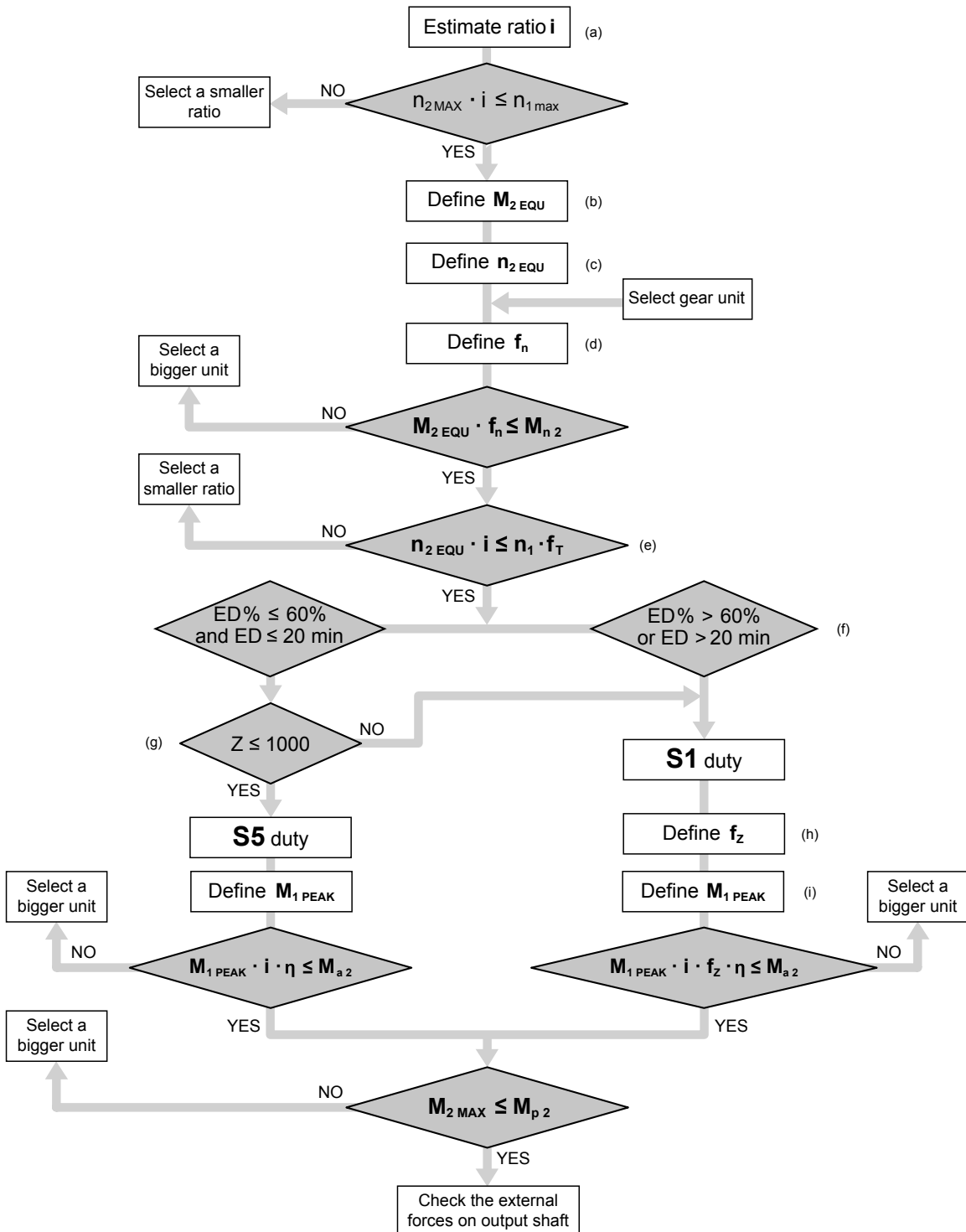
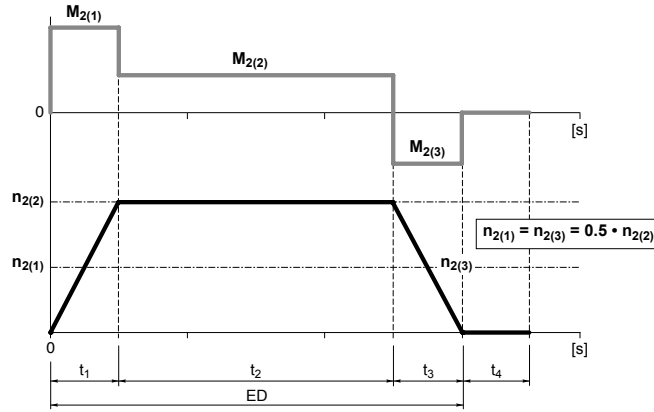



S-M-BOR-NL-CAFS-001-V01

1.3 SERVICE LIFE OF BEARINGS

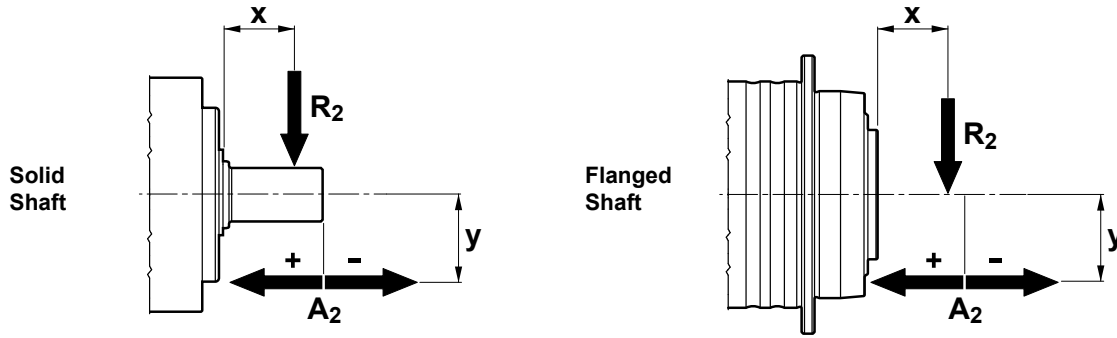

(a)	Maximum radial force applying on output shaft Maximum axial force applying on output shaft	$R_{2\text{ MAX}}$ $A_{2\text{ MAX}}$	[N] [N]	Please consider the specific conditions (e.g. belt drives under acceleration torque)
(b)	Maximum tilting moment applying on output shaft	$M_{T2\text{ MAX}}$	[Nm]	$M_{T2\text{ MAX}} = \frac{R_{2\text{ MAX}} \cdot (x + L_z) \pm A_{2\text{ MAX}} \cdot y}{1000}$
(c)	Equivalent forces applying on output shaft	$R_{2\text{ EQU}}$	[N]	$R_{2\text{ EQU}} = \sqrt[3]{\frac{ n_{2(1)} \cdot t_1 \cdot R_{2(1)} ^3 + \dots + n_{2(n)} \cdot t_n \cdot R_{2(n)} ^3}{ n_{2(1)} \cdot t_1 + \dots + n_{2(n)} \cdot t_n}}$
		$A_{2\text{ EQU}}$	[N]	$A_{2\text{ EQU}} = \sqrt[3]{\frac{ n_{2(1)} \cdot t_1 \cdot A_{2(1)} ^3 + \dots + n_{2(n)} \cdot t_n \cdot A_{2(n)} ^3}{ n_{2(1)} \cdot t_1 + \dots + n_{2(n)} \cdot t_n}}$
(d)	Equivalent tilting moment applying on output shaft	$M_{T2\text{ EQU}}$	[Nm]	$M_{T2\text{ EQU}} = \frac{R_{2\text{ EQU}} \cdot (x + L_z) + A_{2\text{ EQU}} \cdot y}{1000}$
(e)	Equivalent output speed	$n_{2\text{ EQU}}$	[min ⁻¹]	$n_{2\text{ EQU}} = \frac{ n_{2(1)} \cdot t_1 + n_{2(2)} \cdot t_2 + \dots + n_{2(n)} \cdot t_n}{t_1 + t_2 + \dots + t_n}$
(f)	Bearings' basic rating life	L_{10h}	[h]	$L_{10h} = \frac{16666}{n_{2\text{ EQU}}} \cdot \left(\frac{C_B}{M_{T2\text{ EQU}}} \right)^p$

		TQ / TQK 060		TQ / TQK 070		TQ / TQK 090		TQ / TQK 130	TQ / TQK 160
		SB	HB	SB	HB	SB	HB	SB	SB
Lz	[mm]	56	67	64	95	89	96	114	
M_{T2 max}	[Nm]	129.5	221	343	592	772	1233	2331	
C_B	[Nm]	632	1065	1510	2898	3325	6395	9795	
p	—	3	3	3.33	3	3.33	3.33	3.33	

		TQF 060	TQF 070	TQF 090	TQF 130	TQF 160
Lz	[mm]	48	72	78	100	128
M_{T2 max}	[Nm]	115	318	430	1200	3700
C_B	[Nm]	490	1335	1815	5055	16200
p	-	3.33	3.33	3.33	3.33	3.33

		TR 053	TR 060	TR 080	TR 105	TR 130	TR 160	TR 190
		SB	SB	SB	SB	SB	SB	SB
Lz	[mm]	22	23	42	53	74	94	100
M_{T2 max}	[Nm]	16	23	155	278	515	739	1683
C_B	[Nm]	91	143	994	2048	3893	5824	8680
p	—	3	3	3.33	3.33	3.33	3.33	3.33

		MP 053	MP 060	MP 080		MP 105		MP 130	MP 160	MP 190
		SB	SB	SB	HB	SB	HB	SB	SB	SB
Lz	[mm]	22	23	44	42	46	53	74	94	100
M_{T2 max}	[Nm]	16	23	83	155	99	278	515	739	1683
C_B	[Nm]	91	143	407	994	637	2048	3893	5824	8680
p	—	3	3	3	3.33	3	3.33	3.33	3.33	3.33

		LC / LCK 050	LC / LCK / SL 070	LC / LCK / SL 090	LC / LCK / SL 120	LC / LCK 155
Lz	[mm]	22	28	30	39	46
M_{T2 max}	[Nm]	15	54	105	238	522
C_B	[Nm]	106	280	298	813	1588
p	—	3	3	3	3	3

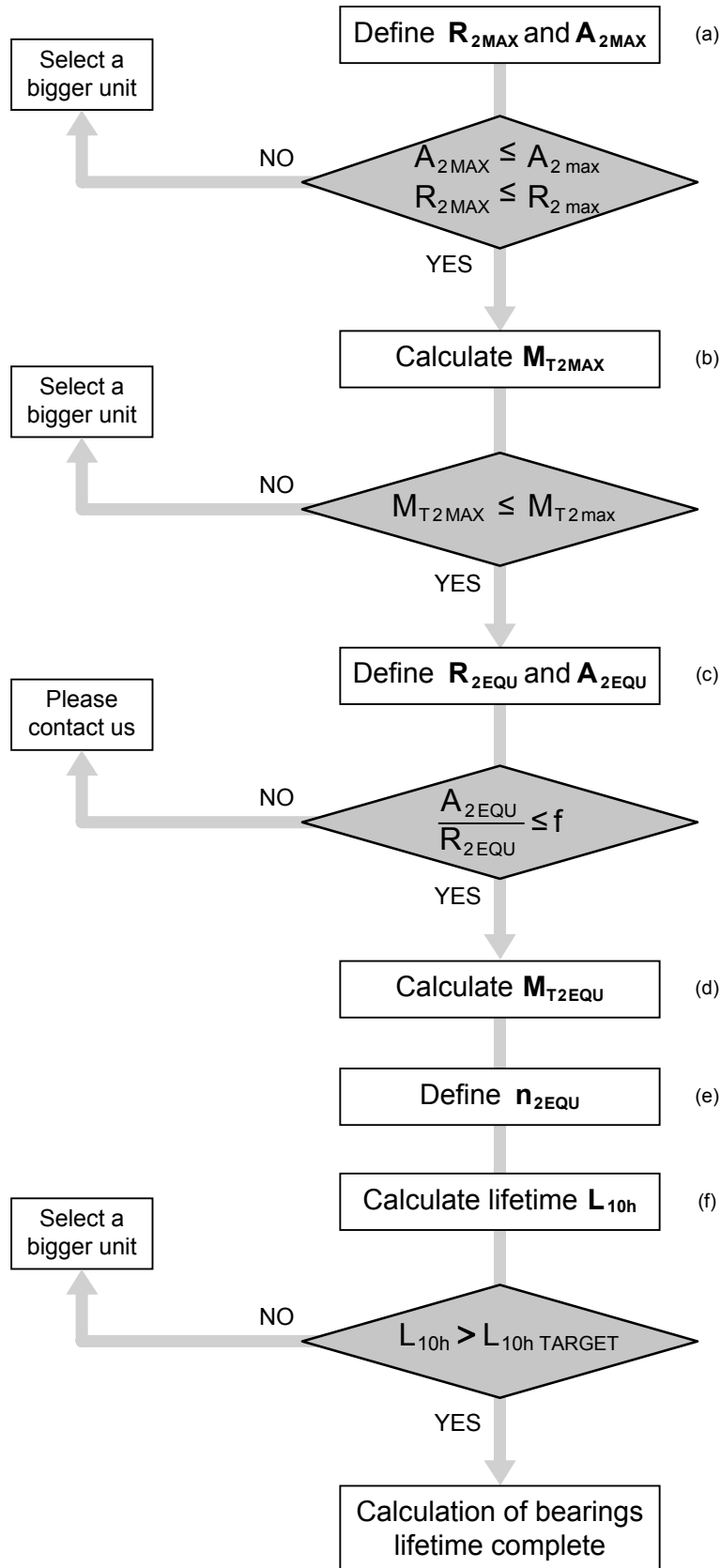

f	TQ / TQK	TQF	TR	MP	LC / LCK	SL	KR
0.26	060 SB ... 090 SB		053 SB ... 060 SB	053 SB ... 105 SB	050 SB ... 155 SB	070 SB ... 120 SB	010 SB ... 040 SB
0.37	130 SB ; 160 SB 070 HB ; 090 HB	060 ... 160	080 SB ... 190 SB	130 SB ... 190 SB 080 HB ; 105 HB			020 HB ... 040 HB

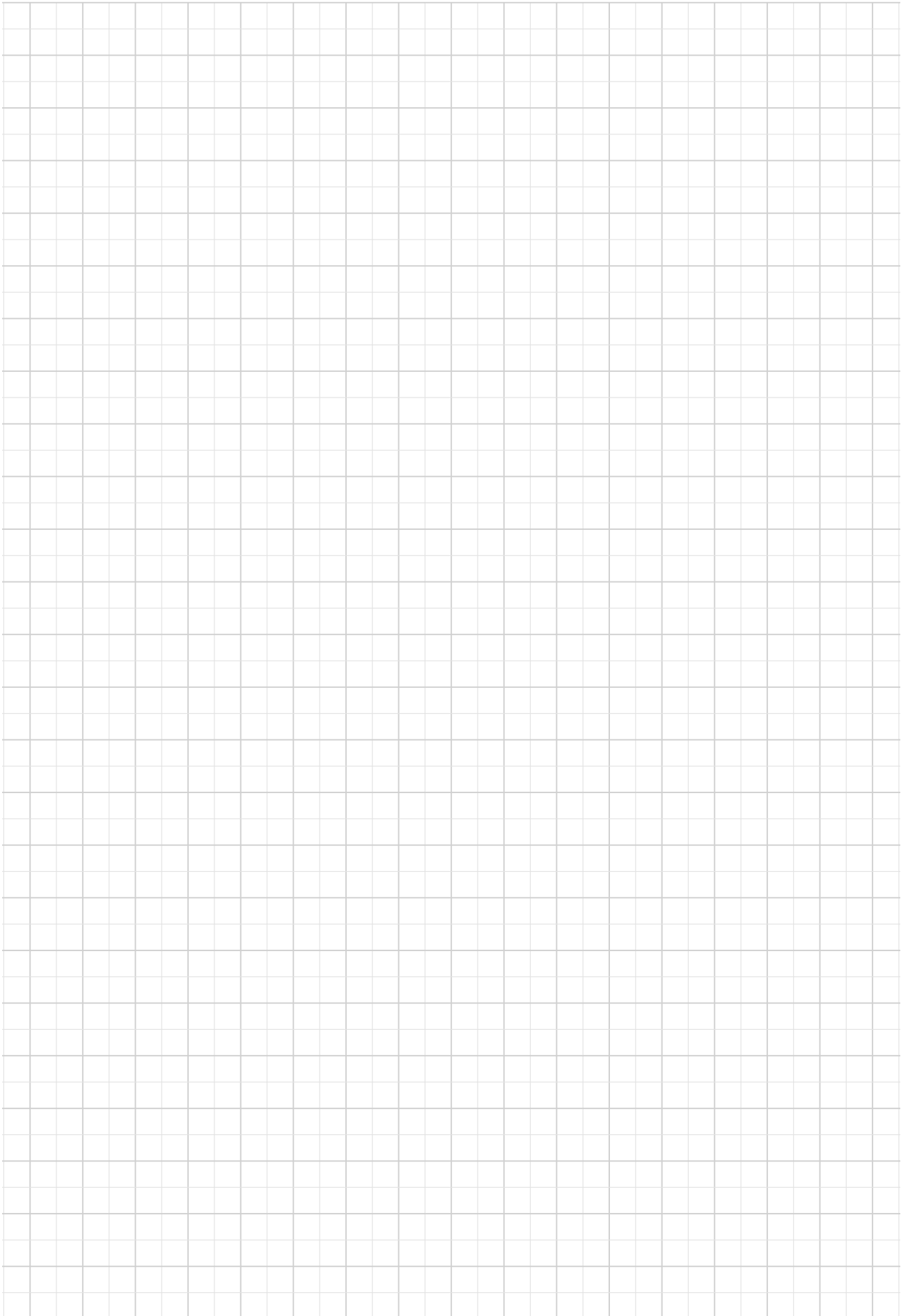

TQ PLANETARY PRECISION INLINE GEARBOX

TQ features a higher positioning. Whether torque, robustness, or precision - this attractive product range scores in every category.



Product Line Up:

- Outstanding Torque Density
- Outstanding Acceleration and Nominal Torques
- Outstanding Radial and Axial Load Capacities
- Designed for Cyclic and Continuous Duty
- Markedly high Torsional Stiffness
- Geometrical Backlash less than 2 arcmin
- Quiet Running
- Universal Design allows any Mounting Orientation

2 FEATURES OF TQ SERIES

TQ

Low backlash planetary drives of TQ series combine outstanding performances with a distinctive Italian style which makes them immediately recognizable amongst similar products within the reference industry.

Their design and construction has been developed with the goal of offering consumers a line of products which feature absolute and consistent Quality, which in turn provides a competitive advantage for machines and systems that adopt them as transmission devices.

- TQ features two classes of precision, corresponding to the following values of circumferential backlash
1-stage units: standard $\varphi_S \leq 3'$ reduced $\varphi_R \leq 2'$ ($\varphi_S \leq 4'$; $\varphi_R \leq 2'$ for TQ 060 and TQ 070)
2-stage units: standard $\varphi_S \leq 5'$ reduced $\varphi_R \leq 3'$ ($\varphi_S \leq 6'$; $\varphi_R \leq 4'$ for TQ 060 and TQ 070)
- A high IP rating (IP65) provides inner parts with protection against the ingress of dust and liquids.
- Input section oil seals made from a Fluoroelastomer compound are supplied as standard.
- Noise pressure level $60 \leq L_p \leq 70$ dB(A). Conditions: distance 1 m ; measured without load and an input speed of $n_1 = 3000$ min⁻¹; $i = 10$.
- Numerous adapters allow matching the most popular brands of servomotors.
- Lubrication optimized for the type of duty specified when ordering.
In the absence of contamination the lubricant requires no periodical changes.

duty	TQ 060 ... TQ 160	other seals
S1 (continuous)	Synthetic oil viscosity ISO VG 220	Fluoroelastomer
S5 (intermittent)	NLGI grease consistency 00	NBR

- Ambient temperature min -20°C, max +30°C. For temperature higher than 30°C please consider derating factor f_T .
- Housing temperature must not exceed $T_{max} = 90^\circ\text{C}$.

[i]	Distribution of nominal torque M_{n2} [Nm]													
	3	4	5	7	10	16	20	25	28	35	40	50	70	100
TQ 060	21	30	30	25	20	30	30	30	30	30	30	30	25	20
TQ 070	45	70	70	60	40	70	70	70	70	70	70	70	60	40
TQ 090	130	200	180	160	110	200	180	180	200	180	200	180	160	110
TQ 130	260	400	400	360	280	400	400	400	400	400	400	400	360	280
TQ 160	530	800	800	750	550	800	800	800	800	800	800	800	750	550

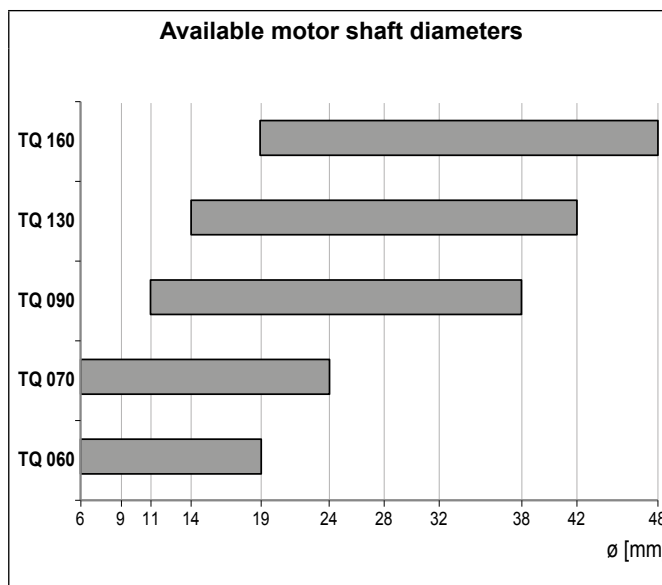
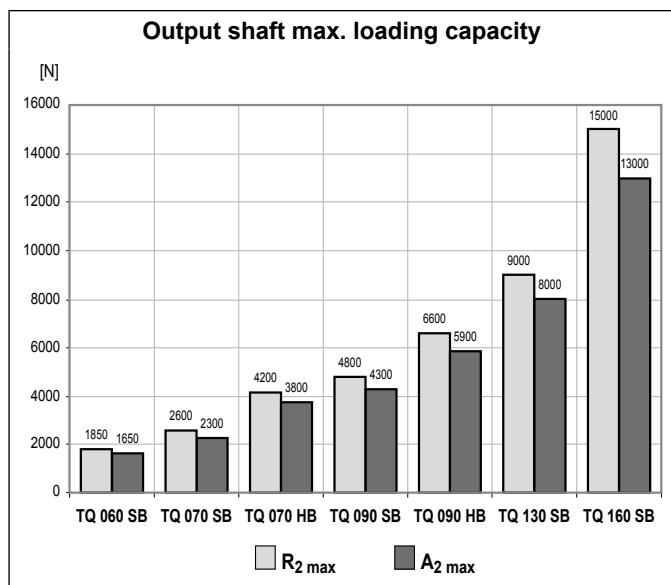

2.1 ORDERING CODE

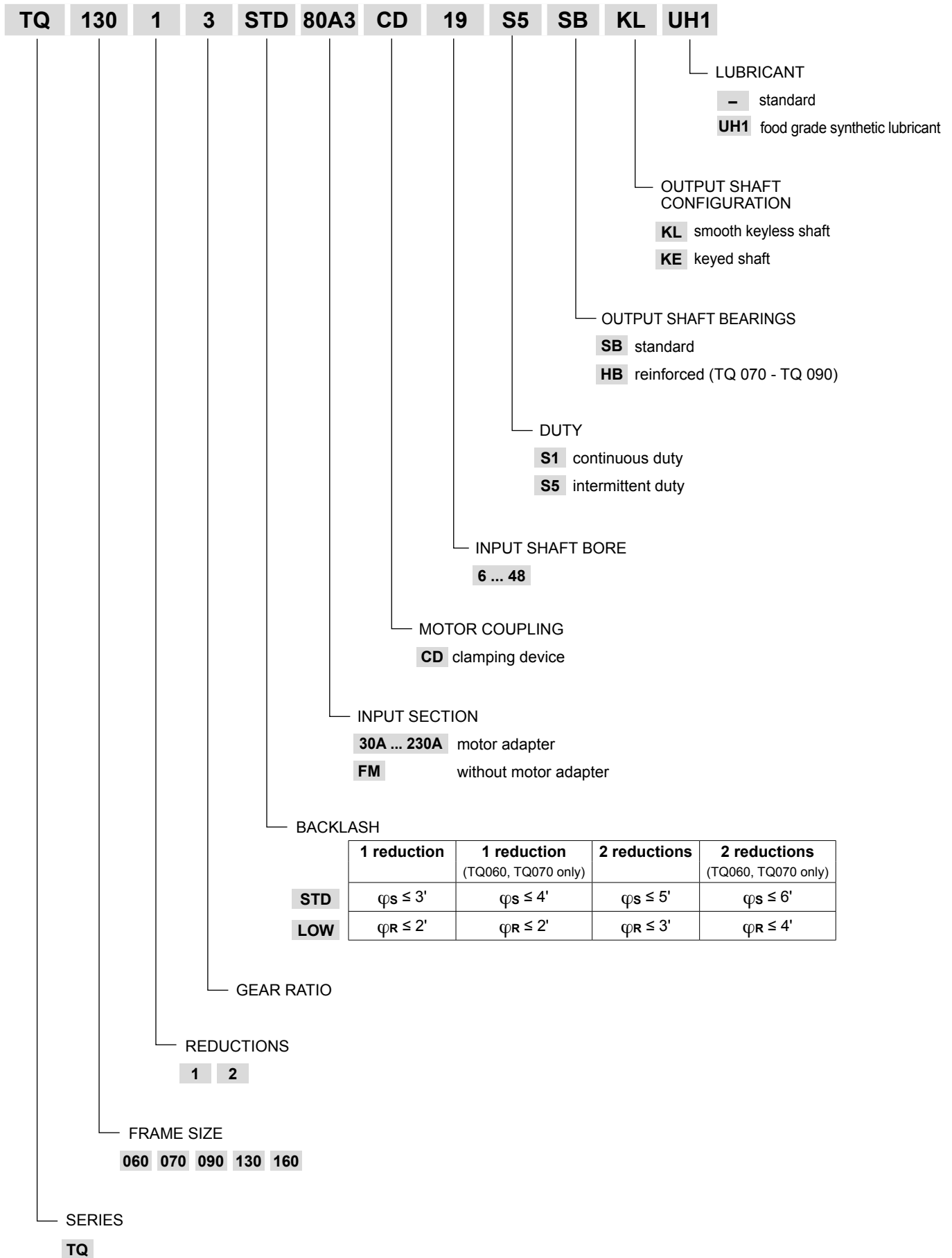

S-M-BOR-NL-CAFS-001-V01

2.2 DIMENSIONS AND TECHNICAL SPECIFICATIONS

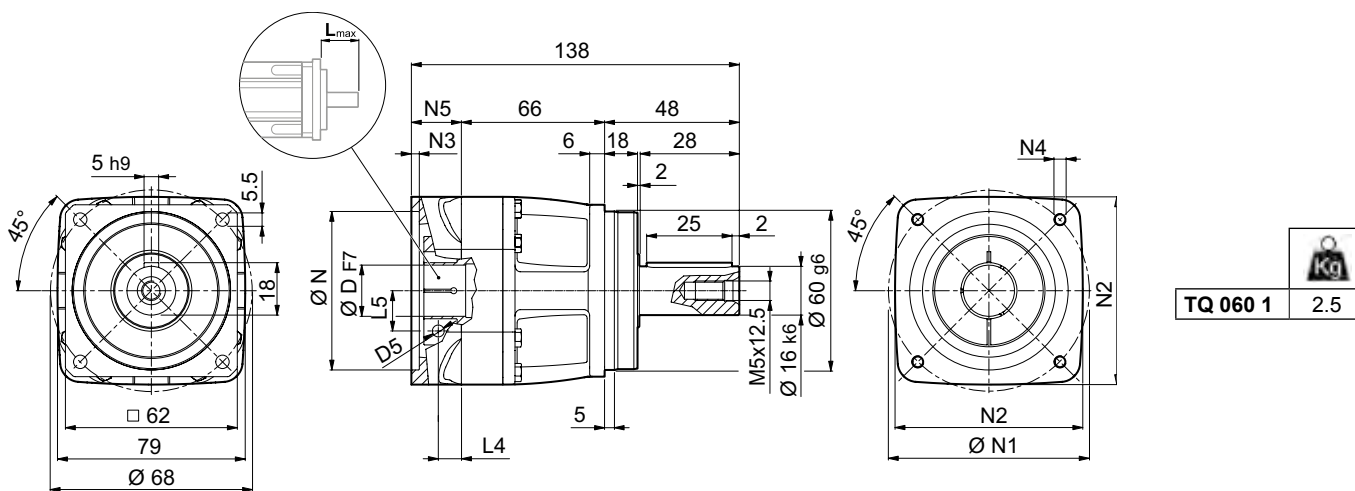

TQ

TQ 060

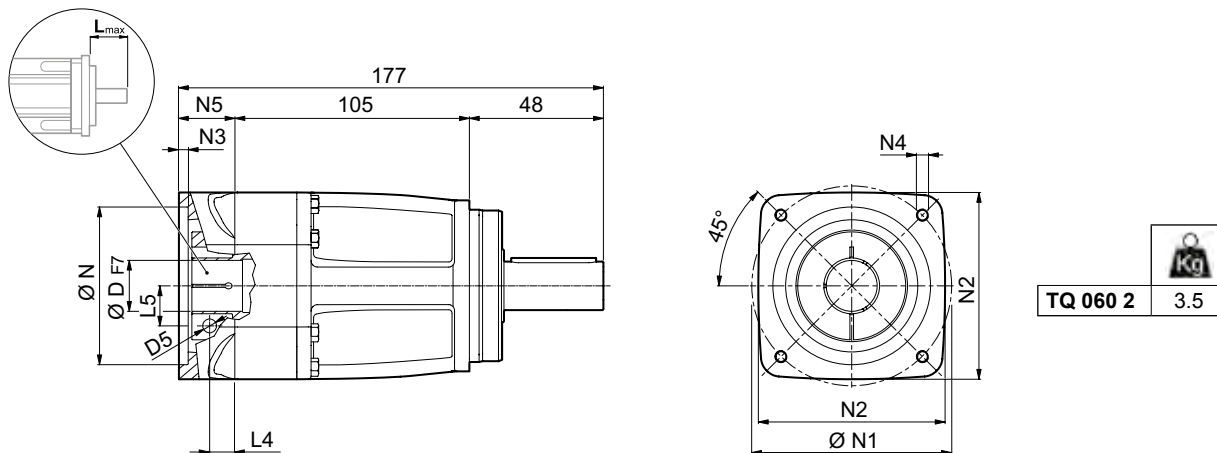

30A ... 110B0



							N	N1	N2	N3	N4	N5	L _{max}
30A	6	-	-	-	-	30	46	60	3.5	M4x10	24	40	
40B1	6	9	11	14	-	40	63	60	3.5	M4x10	24	40	
50A1	6	9	11	14	-	50	60	60	4.0	M4x10	24	40	
50C1	6	9	11	14	-	50	70	60	4.0	M4x10	24	40	
60A2	6	9	11	14	19	60	75	80	4.0	M5x12	24	40	
70B1	6	9	11	14	19	70	90	80	4.0	M5x12	24	40	
80A1	6	9	11	14	19	80	100	100	4.0	M6x14	24	40	
95A	6	9	11	14	19	95	115	100	4.0	M8x24	24	40	
110B0	6	9	11	14	19	110	145	120	4.0	M8x24	24	40	

Please contact us for other motor adapters and input shaft bore.

TQ 060

TQ

FM

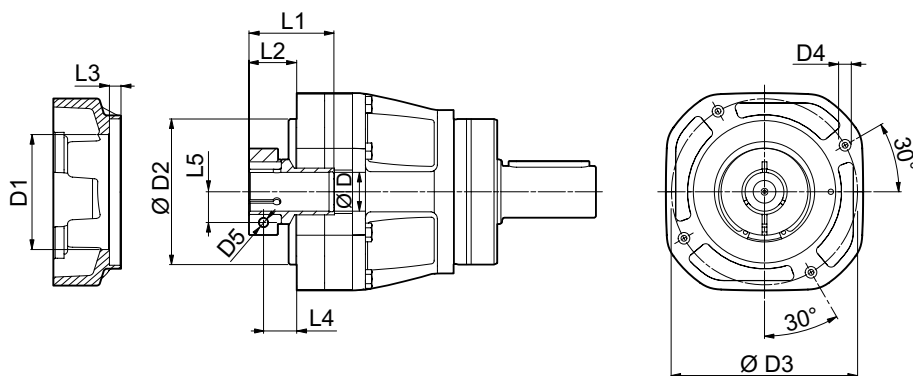

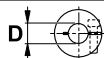
	D1	D2	D3	D4	D5	L1	L2	L3	L4	L5
6	37	59	72	M5x11	M4	31.5	15.5	4.5	10.5	8
9	49	59	72	M5x11	M5	35	19	4.5	11.5	10.5
11	49	59	72	M5x11	M6	35	19	4.5	11.5	12.5
14	49	59	72	M5x11	M6	35	19	4.5	11.5	14.5
19	54	59	72	M5x11	M6	35	19	4.5	11.5	16.5

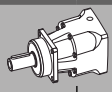
	M_{n2}	M_{a2}	M_{p2}	n_1	$n_{1\max}$	$\varphi_S \leq \varphi_R$		C_t	$R_{2\max}$	$A_{2\max}$	η	J_G [kgcm ²]		
						[Nm]	[Nm]					[Nm]	[min ⁻¹]	[min ⁻¹]
TQ 060 1_3	21	32	60	3500	6000	4'	2'	4.8	1850	1650	97	0.36	0.47	0.51
TQ 060 1_4	30	45	80	3500	6000	4'	2'	4.8	1850	1650	97	0.28	0.39	0.43
TQ 060 1_5	30	45	80	3500	6000	4'	2'	4.8	1850	1650	97	0.25	0.36	0.40
TQ 060 1_7	25	38	70	4000	6000	4'	2'	4.8	1850	1650	97	0.22	0.33	0.37
TQ 060 1_10	20	30	55	4000	6000	4'	2'	4.8	1850	1650	97	0.21	0.32	0.36
TQ 060 2_16	30	45	80	4500	6000	6'	4'	4.7	1850	1650	94	0.27	0.39	0.42
TQ 060 2_20	30	45	80	4500	6000	6'	4'	4.7	1850	1650	94	0.27	0.39	0.42
TQ 060 2_25	30	45	80	4500	6000	6'	4'	4.7	1850	1650	94	0.24	0.36	0.39
TQ 060 2_28	30	45	80	4500	6000	6'	4'	4.7	1850	1650	94	0.22	0.33	0.37
TQ 060 2_35	30	45	80	4500	6000	6'	4'	4.7	1850	1650	94	0.22	0.33	0.37
TQ 060 2_40	30	45	80	4500	6000	6'	4'	4.7	1850	1650	94	0.21	0.32	0.36
TQ 060 2_50	30	45	80	4500	6000	6'	4'	4.7	1850	1650	94	0.21	0.32	0.36
TQ 060 2_70	25	38	70	5000	6000	6'	4'	4.7	1850	1650	94	0.21	0.32	0.36
TQ 060 2_100	20	30	55	5000	6000	6'	4'	4.7	1850	1650	94	0.20	0.32	0.35

S-M-BOR-NL-CAFS-001-V01

TQ 070

TQ

50C ... 130A

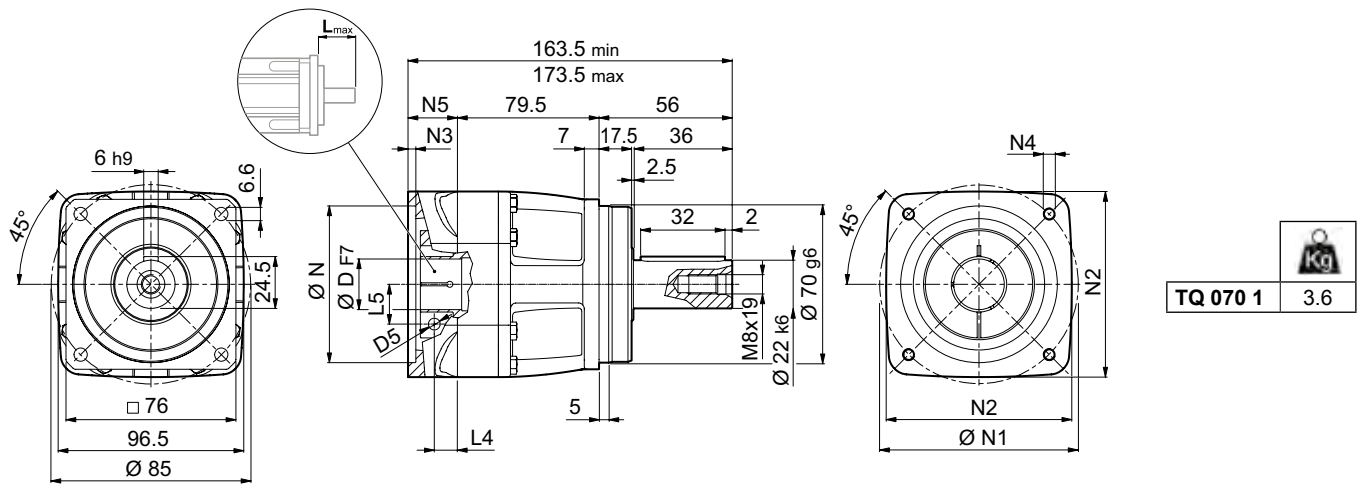

30A ... 110B0

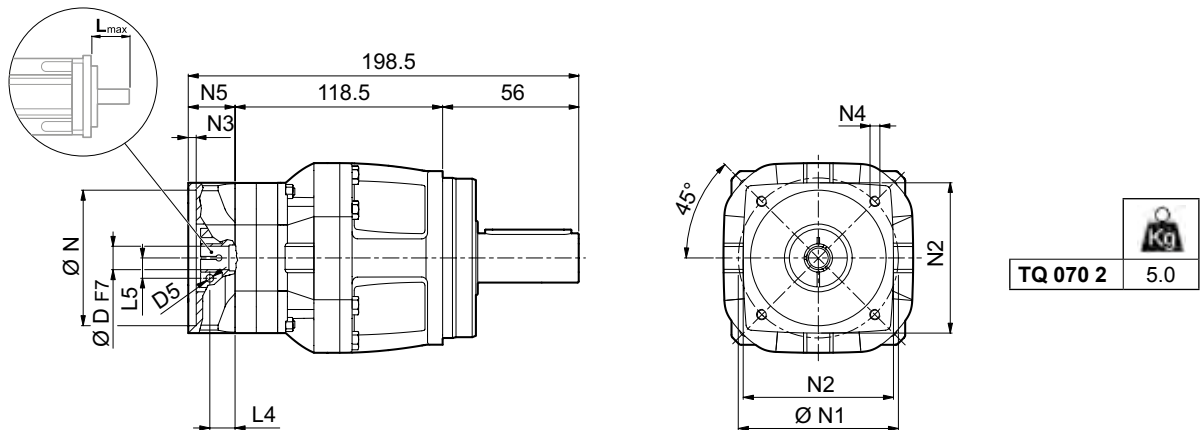

Motor	D						N	N1	N2	N3	N4	N5	L _{max}
	6	9	11	14	19	24							
TQ 070 1													
50C2	6	9	11	14	–	–	50	70	80	6.5	M4x12	28	50
60A3	6	9	11	14	19	–	60	75	80	6.5	M5x14	28	50
70B2	6	9	11	14	19	–	70	90	80	6.5	M5x14	28	50
80A2	6	9	11	14	19	–	80	100	100	6.5	M6x14	28	50
95A1	6	9	11	14	19	24	95	115	100	6.5	M8x18	28	50
110A1	6	9	11	14	19	24	110	130	120	6.5	M8x18	28	50
110B1	6	9	11	14	19	24	110	145	120	6.5	M8x20	38	60
130A	6	9	11	14	19	24	130	165	140	6.5	M10x19	28	50
TQ 070 2													
30A	6	–	–	–	–	–	30	46	60	3.5	M4x10	24	40
40B1	6	9	11	14	–	–	40	63	60	3.5	M4x10	24	40
50A1	6	9	11	14	–	–	50	60	60	4.0	M4x10	24	40
50C1	6	9	11	14	–	–	50	70	60	4.0	M4x10	24	40
60A2	6	9	11	14	19	–	60	75	80	4.0	M5x12	24	40
70B1	6	9	11	14	19	–	70	90	80	4.0	M5x12	24	40
80A1	6	9	11	14	19	–	80	100	100	4.0	M6x14	24	40
95A	6	9	11	14	19	–	95	115	100	4.0	M8x24	24	40
110B0	6	9	11	14	19	–	110	145	120	4.0	M8x24	24	40

Please contact us for other motor adapters and input shaft bore.

TQ 070

FM

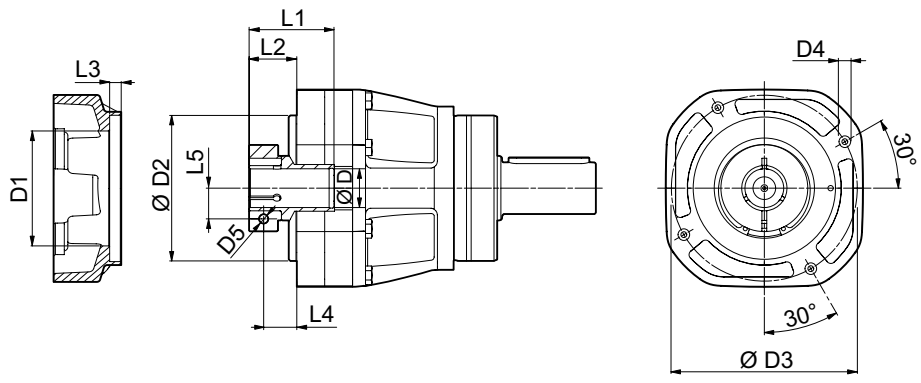

D	D1	D2	D3	D4	D5	L1	L2	L3	L4	L5
TQ 070 1										
6	51	70	85	M6x11	M4	42	20	5	12.5	12.5
9	51	70	85	M6x11	M5	42	20	5	12.5	14.5
11	51	70	85	M6x11	M6	42	20	5	12.5	12.5
14	51	70	85	M6x11	M6	42	20	5	12.5	14.5
19	51	70	85	M6x11	M6	42	20	5	12.5	16.5
24	60	70	85	M6x11	M6	43.5	21.5	5	12.5	19
TQ 070 2										
6	37	59	72	M5x11	M4	31.5	15.5	4.5	10.5	8
9	49	59	72	M5x11	M5	35	19	4.5	11.5	10.5
11	49	59	72	M5x11	M6	35	19	4.5	11.5	12.5
14	49	59	72	M5x11	M6	35	19	4.5	11.5	14.5
19	54	59	72	M5x11	M6	35	19	4.5	11.5	16.5

i	M _{n2} [Nm]	M _{a2} [Nm]	M _{p2} [Nm]	n ₁ [min ⁻¹]	n _{1 max} [min ⁻¹]	φ _S φ _R ≤		C _t [Nm/arcmin]	SB		HB		η ₁ %	J _G [kgcm ²]			
						R _{2 max} [N]	A _{2 max} [N]		R _{2 max} [N]	A _{2 max} [N]	D	6 - 9		11 - 14	19	24	
TQ 070 1_3	45	65	120	3000	6000	4'	2'	11.3	2600	2300	4200	3800	97	-	0.99	1.02	1.15
TQ 070 1_4	70	100	180	3000	6000	4'	2'	11.3	2600	2300	4200	3800	97	-	0.76	0.79	0.92
TQ 070 1_5	70	100	180	3000	6000	4'	2'	11.3	2600	2300	4200	3800	97	-	0.67	0.70	0.83
TQ 070 1_7	60	90	160	3500	6000	4'	2'	11.3	2600	2300	4200	3800	97	-	0.59	0.62	0.75
TQ 070 1_10	40	60	110	3500	6000	4'	2'	11.3	2600	2300	4200	3800	97	-	0.55	0.58	0.71
TQ 070 2_16	70	100	180	3500	6000	6'	4'	11.3	2600	2300	4200	3800	94	0.28	0.40	0.43	-
TQ 070 2_20	70	100	180	3500	6000	6'	4'	11.3	2600	2300	4200	3800	94	0.28	0.39	0.43	-
TQ 070 2_25	70	100	180	3500	6000	6'	4'	11.3	2600	2300	4200	3800	94	0.25	0.36	0.40	-
TQ 070 2_28	70	100	180	3500	6000	6'	4'	11.3	2600	2300	4200	3800	94	0.22	0.34	0.37	-
TQ 070 2_35	70	100	180	3500	6000	6'	4'	11.3	2600	2300	4200	3800	94	0.22	0.34	0.37	-
TQ 070 2_40	70	100	180	3500	6000	6'	4'	11.3	2600	2300	4200	3800	94	0.21	0.32	0.36	-
TQ 070 2_50	70	100	180	3500	6000	6'	4'	11.3	2600	2300	4200	3800	94	0.21	0.32	0.36	-
TQ 070 2_70	60	90	160	4000	6000	6'	4'	11.3	2600	2300	4200	3800	94	0.21	0.32	0.36	-
TQ 070 2_100	40	60	110	4500	6000	6'	4'	11.3	2600	2300	4200	3800	94	0.21	0.32	0.36	-

S-M-BOR-NL-CAFS-001-V01

TQ 090

TQ

60A4 ... 180A1

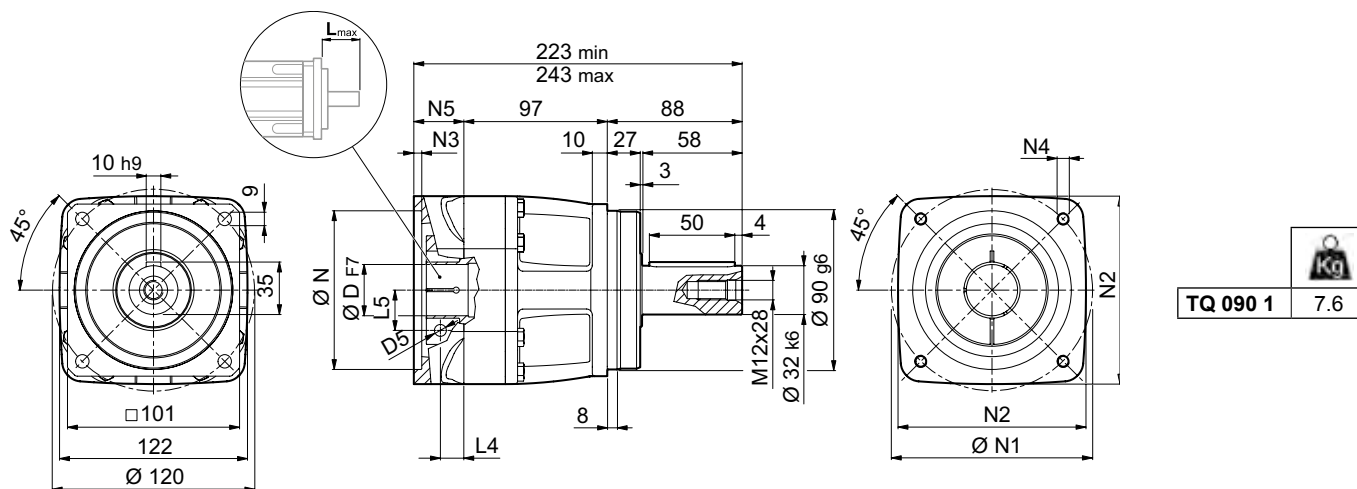

50C2 ... 130A

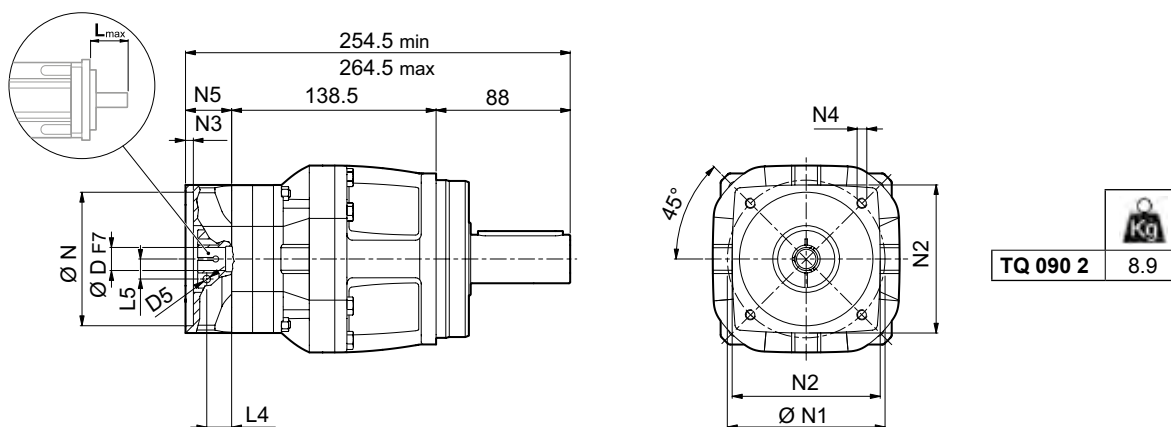

	D							N	N1	N2	N3	N4	N5	L _{max}
TQ 090 1														
60A4	11	14	19	-	-	-	-	60	75	100	6.5	M5x14	38	60
80A3	11	14	19	-	-	-	-	80	100	100	6.5	M6x14	38	60
95A2	11	14	19	24	28	-	-	95	115	100	6.5	M8x18	38	60
110A2	11	14	19	24	-	-	-	110	130	122	6.5	M8x20	38	60
110B1	11	14	19	24	28	-	-	110	145	122	6.5	M8x20	38	60
130A1	11	14	19	24	28	32	-	130	165	140	6.5	M10x20	38	60
180A	11	14	19	24	28	32	-	180	215	190	6.5	M14x38	38	60
180A1	11	14	19	24	28	32	38	180	215	190	6.5	M14x28	58	80
TQ 090 2														
50C2	11	14	-	-	-	-	-	50	70	80	6.5	M4x12	28	50
60A3	11	14	19	-	-	-	-	60	75	80	6.5	M5x14	28	50
70B2	11	14	19	-	-	-	-	70	90	80	6.5	M5x14	28	50
80A2	11	14	19	-	-	-	-	80	100	100	6.5	M6x14	28	50
95A1	11	14	19	24	-	-	-	95	115	100	6.5	M8x18	28	50
110A1	11	14	19	24	-	-	-	110	130	120	6.5	M8x18	28	50
110B1	11	14	19	24	-	-	-	110	145	120	6.5	M8x20	38	60
130A	11	14	19	24	-	-	-	130	165	140	6.5	M10x19	28	50

Please contact us for other motor adapters and input shaft bore.

TQ 090

FM

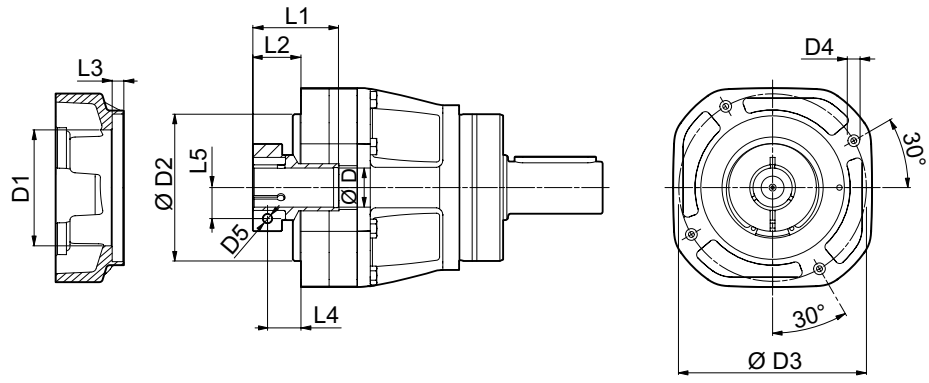

D	D1	D2	D3	D4	D5	L1	L2	L3	L4	L5
TQ 090 1										
11	51	90	115	M8x13	M6	50	28	6.5	20.5	14.5
14	51	90	115	M8x13	M6	50	28	6.5	20.5	14.5
19	51	90	115	M8x13	M6	50	28	6.5	20.5	16.5
24	60	90	115	M8x13	M6	51.5	29.5	6.5	20.5	19
28	72	90	115	M8x13	M8	51.5	29.5	6.5	20.5	22.5
32	72	90	115	M8x13	M8	51.5	29.5	6.5	20.5	24.5
38	80	90	115	M8x13	M8	51.5	29.5	6.5	20.5	28
TQ 090 2										
6	51	70	85	M6x11	M4	42	20	5	12.5	12.5
9	51	70	85	M6x11	M5	42	20	5	12.5	14.5
11	51	70	85	M6x11	M6	42	20	5	12.5	12.5
14	51	70	85	M6x11	M6	42	20	5	12.5	14.5
19	51	70	85	M6x11	M6	42	20	5	12.5	16.5
24	60	70	85	M6x11	M6	43.5	21.5	5	12.5	19

	M _{n 2}	M _{a 2}	M _{p 2}	n ₁	n _{1 max}	φ _S	φ _R	C _t	SB		HB		η	J _e [kgcm ²]				
									R _{2 max}	A _{2 max}	R _{2 max}	A _{2 max}		11	14 - 19	24	28	32-38
i	[Nm]	[Nm]	[Nm]	[min ⁻¹]	[min ⁻¹]	≤	[arcmin]	$\frac{Nm}{arcmin}$	[N]	[N]	[N]	[N]	%					
TQ 090 1_3	130	200	400	2500	4500	3'	2'	28	4800	4300	6600	5900	97	-	2.18	2.30	2.69	4.48
TQ 090 1_4	200	300	500	2500	4500	3'	2'	28	4800	4300	6600	5900	97	-	1.63	1.75	2.14	3.93
TQ 090 1_5	180	280	500	2500	4500	3'	2'	28	4800	4300	6600	5900	97	-	1.39	1.52	1.90	3.70
TQ 090 1_7	160	250	500	3000	4500	3'	2'	28	4800	4300	6600	5900	97	-	1.19	1.32	1.70	3.50
TQ 090 1_10	110	170	350	3000	4500	3'	2'	28	4800	4300	6600	5900	97	-	1.08	1.21	1.59	3.39
TQ 090 2_16	200	300	500	3000	4500	5'	3'	28	4800	4300	6600	5900	94	0.70	0.80	0.94	-	-
TQ 090 2_20	180	280	500	3000	4500	5'	3'	28	4800	4300	6600	5900	94	0.69	0.79	0.92	-	-
TQ 090 2_25	180	280	500	3000	4500	5'	3'	28	4800	4300	6600	5900	94	0.60	0.70	0.83	-	-
TQ 090 2_28	200	300	500	3000	4500	5'	3'	28	4800	4300	6600	5900	94	0.53	0.63	0.76	-	-
TQ 090 2_35	180	280	500	3000	4500	5'	3'	28	4800	4300	6600	5900	94	0.52	0.62	0.75	-	-
TQ 090 2_40	200	300	500	3000	4500	5'	3'	28	4800	4300	6600	5900	94	0.48	0.58	0.71	-	-
TQ 090 2_50	180	280	500	3500	4500	5'	3'	28	4800	4300	6600	5900	94	0.48	0.58	0.71	-	-
TQ 090 2_70	160	250	500	4000	4500	5'	3'	28	4800	4300	6600	5900	94	0.48	0.58	0.71	-	-
TQ 090 2_100	110	170	350	4000	4500	5'	3'	28	4800	4300	6600	5900	94	0.48	0.58	0.71	-	-

S-M-BOR-NL-CAFS-001-V01

TQ 130

TQ

80A3 ... 200A

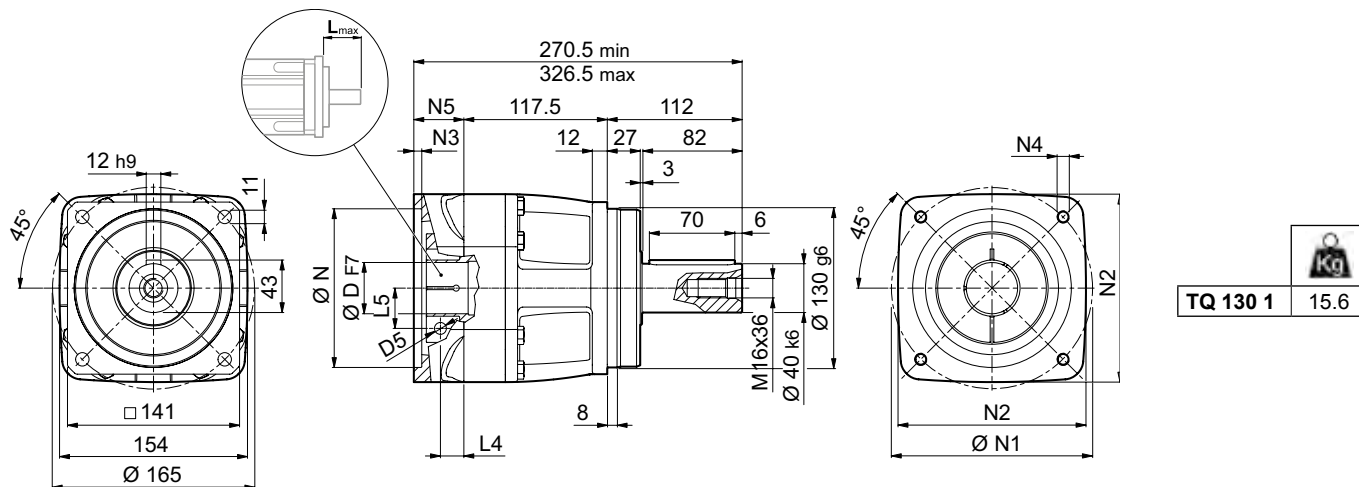

60A4 ... 180A1

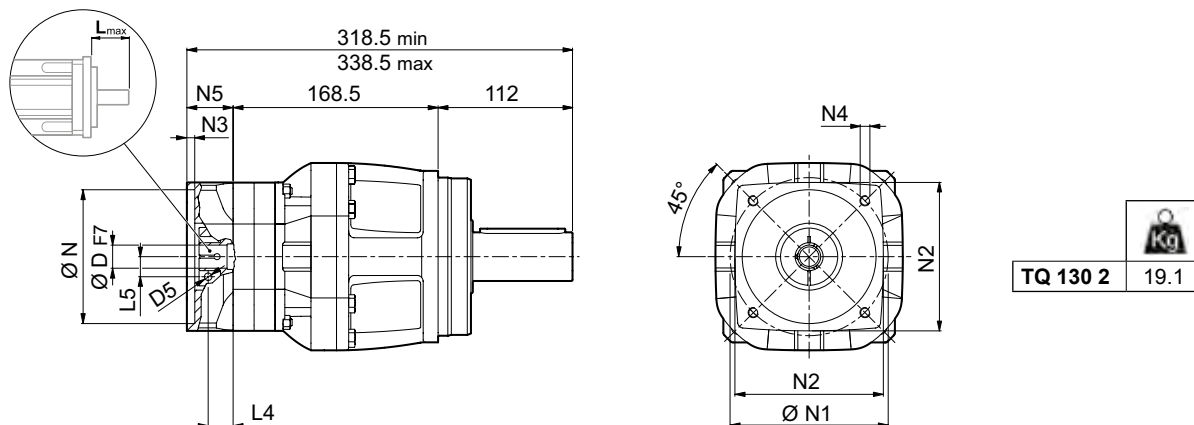

	D						N	N1	N2	N3	N4	N5	L _{max}
TQ 130 1													
80A3	14	19	-	-	-	-	80	100	130	6.5	M6x14	41	60
95A2	14	19	24	28	-	-	95	115	130	6.5	M8x18	41	60
110A2	14	19	24	-	-	-	110	130	130	6.5	M8x20	41	60
110B1	14	19	24	28	-	-	110	145	130	6.5	M8x20	41	60
130A1	14	19	24	28	32	-	130	165	154	6.5	M10x20	41	60
180A	14	19	24	28	32	-	180	215	190	6.5	M14x28	41	60
180A1	14	19	24	28	32	38	180	215	190	6.5	M14x28	61	80
200A	14	19	24	28	32	38	200	235	210	6.5	M14x28	97	110
TQ 130 2													
60A4	14	19	-	-	-	-	60	75	100	6.5	M5x14	38	60
80A3	14	19	-	-	-	-	80	100	100	6.5	M6x14	38	60
95A2	14	19	24	28	-	-	95	115	100	6.5	M8x18	38	60
110A2	14	19	24	-	-	-	110	130	122	6.5	M8x20	38	60
110B1	14	19	24	28	-	-	110	145	122	6.5	M8x20	38	60
130A1	14	19	24	28	32	-	130	165	140	6.5	M10x20	38	60
180A	14	19	24	28	32	-	180	215	190	6.5	M14x38	38	60
180A1	14	19	24	28	32	38	180	215	190	6.5	M14x28	58	80

Please contact us for other motor adapters and input shaft bore.

TQ 130

TQ

FM

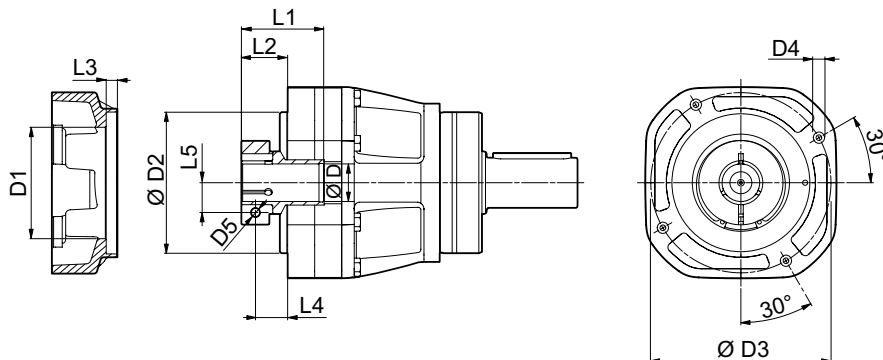

D	D1	D2	D3	D4	D5	L1	L2	L3	L4	L5
TQ 130 1										
14	54	120	140	M10x16	M6	50	31	7.5	23.5	16.5
19	54	120	140	M10x16	M6	50	31	7.5	23.5	16.5
24	70	120	140	M10x16	M6	51.5	32.5	7.5	23.5	19
28	70	120	140	M10x16	M8	51.5	32.5	7.5	23.5	22.5
32	72	120	140	M10x16	M8	51.5	32.5	7.5	23.5	24.5
38	100	120	140	M10x16	M8	54	35	7.5	23.5	28
42	114	120	140	M10x16	M10	51.5	38.5	7.5	23.5	33
TQ 130 2										
11	51	90	115	M8x13	M6	50	28	6.5	20.5	14.5
14	51	90	115	M8x13	M6	50	28	6.5	20.5	14.5
19	51	90	115	M8x13	M6	50	28	6.5	20.5	16.5
24	60	90	115	M8x13	M6	51.5	29.5	6.5	20.5	19
28	72	90	115	M8x13	M8	51.5	29.5	6.5	20.5	22.5
32	72	90	115	M8x13	M8	51.5	29.5	6.5	20.5	24.5
38	80	90	115	M8x13	M8	51.5	29.5	6.5	20.5	28

i	M _{n 2} [Nm]	M _{a 2} [Nm]	M _{p 2} [Nm]	n ₁ [min ⁻¹]	n _{1 max} [min ⁻¹]	ϕ _S ϕ _R ≤		C _t [Nm arcmin]	R _{2 max} [N]	A _{2 max} [N]	η %	J _G [kgcm ²]				
						14	19 - 24					28 - 32	38	42		
TQ 130 1_3	260	400	900	2100	4000	3'	2'	59	9000	8000	97	-	10.02	10.48	11.12	17.12
TQ 130 1_4	400	600	1000	2100	4000	3'	2'	59	9000	8000	97	-	6.38	6.85	7.49	13.49
TQ 130 1_5	400	600	1000	2500	4000	3'	2'	59	9000	8000	97	-	5.01	5.47	6.11	12.11
TQ 130 1_7	360	550	950	2500	4000	3'	2'	59	9000	8000	97	-	3.82	4.28	4.93	10.93
TQ 130 1_10	280	420	900	2500	4000	3'	2'	59	9000	8000	97	-	3.15	3.61	4.25	10.25
TQ 130 2_16	400	600	1000	2800	4000	5'	3'	58	9000	8000	94	1.72	1.87	3.53	4.05	-
TQ 130 2_20	400	600	1000	2800	4000	5'	3'	58	9000	8000	94	1.64	1.80	3.46	3.98	-
TQ 130 2_25	400	600	1000	2800	4000	5'	3'	58	9000	8000	94	1.39	1.55	3.21	3.73	-
TQ 130 2_28	400	600	1000	2800	4000	5'	3'	58	9000	8000	94	1.20	1.36	3.02	3.54	-
TQ 130 2_35	400	600	1000	2800	4000	5'	3'	58	9000	8000	94	1.17	1.33	2.99	3.51	-
TQ 130 2_40	400	600	1000	3200	4000	5'	3'	58	9000	8000	94	1.07	1.23	2.89	3.41	-
TQ 130 2_50	400	600	1000	3200	4000	5'	3'	58	9000	8000	94	1.06	1.21	2.87	3.39	-
TQ 130 2_70	360	550	950	3500	4000	5'	3'	58	9000	8000	94	1.05	1.20	2.86	3.38	-
TQ 130 2_100	280	420	900	4000	4000	5'	3'	58	9000	8000	94	1.04	1.20	2.86	3.38	-

S-M-BOR-NL-CAFS-001-V01

TQ 160

95A2 ... 230A

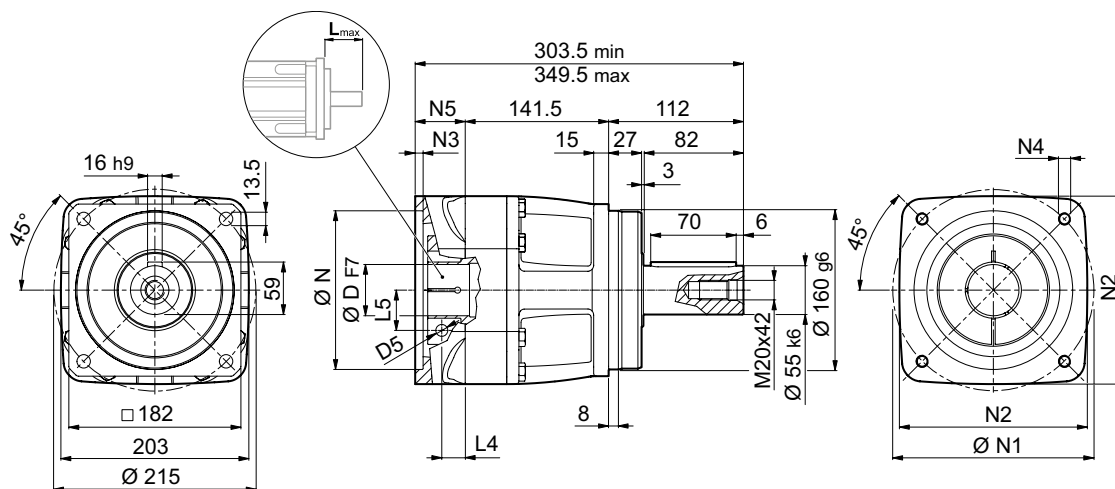

	TQ 160 1	29.7
--	-----------------	------

80A3 ... 200A

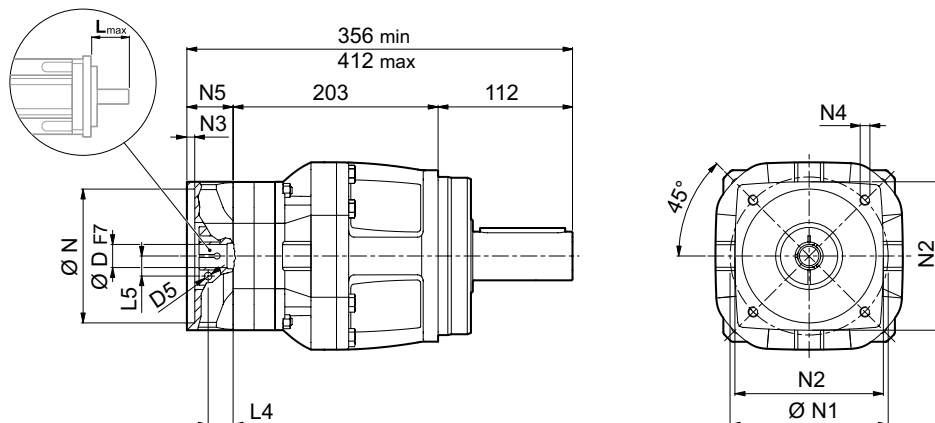

	TQ 160 2	37.4
--	-----------------	------

								N	N1	N2	N3	N4	N5	Lmax
TQ 160 1														
95A2	19	24	28	-	-	-	-	95	115	158	6.5	M8x20	50	60
110A2	19	24	-	-	-	-	-	110	130	158	6.5	M8x20	50	60
130A1	19	24	28	32	-	-	-	130	165	158	6.5	M10x20	50	60
180A	19	24	28	32	-	-	-	180	215	203	6.5	M14x28	50	60
180A1	19	24	28	32	38	-	-	180	215	205	6.5	M14x28	60	80
200A	19	24	28	32	38	42	48	200	235	220	6.5	M14x28	96	110
230A	19	24	28	32	38	42	48	230	265	240	6.5	M14x28	96	110
TQ 160 2														
80A3	19	-	-	-	-	-	-	80	100	130	6.5	M6x14	41	60
95A2	19	24	28	-	-	-	-	95	115	130	6.5	M8x18	41	60
110A2	19	24	-	-	-	-	-	110	130	130	6.5	M8x20	41	60
110B1	19	24	28	-	-	-	-	110	145	130	6.5	M8x20	41	60
130A1	19	24	28	32	-	-	-	130	165	154	6.5	M10x20	41	60
180A	19	24	28	32	-	-	-	180	215	190	6.5	M14x28	41	60
180A1	19	24	28	32	38	-	-	180	215	190	6.5	M14x28	61	80
200A	19	24	28	32	38	42	-	200	235	210	6.5	M14x28	97	110

Please contact us for other motor adapters and input shaft bore.

TQ 160

TQ

FM

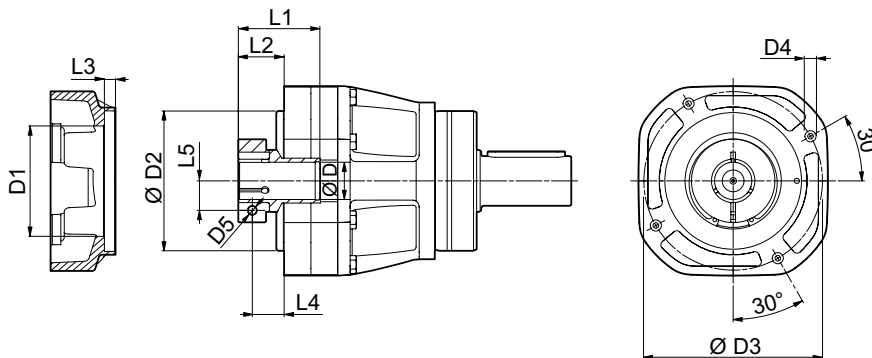

D	D1	D2	D3	D4	D5	L1	L2	L3	L4	L5
TQ 160 1										
19	58	150	175	M12x20	M6	47	37	9.5	28	19
24	58	150	175	M12x20	M6	47	37	9.5	28	19
28	70	150	175	M12x20	M8	47	37	9.5	28	22.5
32	72	150	175	M12x20	M8	47	37	9.5	28	24.5
38	100	150	175	M12x20	M8	59.5	39.5	9.5	28	28
42	114	150	175	M12x20	M10	57	43	9.5	28	33
48	125	150	175	M12x20	M12	57	43	9.5	28	36.5
TQ 160 2										
14	54	120	140	M10x16	M6	50	31	7.5	23.5	16.5
19	54	120	140	M10x16	M6	50	31	7.5	23.5	16.5
24	70	120	140	M10x16	M6	51.5	32.5	7.5	23.5	19
28	70	120	140	M10x16	M8	51.5	32.5	7.5	23.5	22.5
32	72	120	140	M10x16	M8	51.5	32.5	7.5	23.5	24.5
38	100	120	140	M10x16	M8	54	35	7.5	23.5	28
42	114	120	140	M10x16	M10	51.5	38.5	7.5	23.5	33

i	M _{n 2} [Nm]	M _{a 2} [Nm]	M _{p 2} [Nm]	n ₁ [min ⁻¹]	n _{1 max} [min ⁻¹]	φ _s φ _R ≤		C _t [Nm/arcmin]	R _{2 max} [N]	A _{2 max} [N]	η %	J _G [kgcm ²]				
						19	24 - 28					32 - 38	42	48		
TQ 160 1_3	530	800	1500	1500	3500	3'	2'	170	15000	13000	97	-	29.58	29.99	32.89	45.99
TQ 160 1_4	800	1200	2000	1500	3500	3'	2'	170	15000	13000	97	-	18.03	18.44	21.33	34.44
TQ 160 1_5	800	1200	2000	1800	3500	3'	2'	170	15000	13000	97	-	11.76	12.17	15.06	28.17
TQ 160 1_7	750	1150	2000	2500	3500	3'	2'	170	15000	13000	97	-	9.27	9.68	12.58	25.68
TQ 160 1_10	550	850	1600	2500	3500	3'	2'	170	15000	13000	97	-	7.05	7.46	10.35	23.46
TQ 160 2_16	800	1200	2000	2800	3500	5'	3'	170	15000	13000	94	6.52	7.05	7.77	13.77	-
TQ 160 2_20	800	1200	2000	2800	3500	5'	3'	170	15000	13000	94	6.16	6.69	7.41	13.41	-
TQ 160 2_25	800	1200	2000	2800	3500	5'	3'	170	15000	13000	94	4.81	5.34	6.06	12.06	-
TQ 160 2_28	800	1200	2000	2800	3500	5'	3'	170	15000	13000	94	3.77	4.30	5.02	11.02	-
TQ 160 2_35	800	1200	2000	2800	3500	5'	3'	170	15000	13000	94	3.65	4.18	4.90	10.90	-
TQ 160 2_40	800	1200	2000	2800	3500	5'	3'	170	15000	13000	94	3.05	3.57	4.30	10.30	-
TQ 160 2_50	800	1200	2000	2800	3500	5'	3'	170	15000	13000	94	2.99	3.52	4.24	10.24	-
TQ 160 2_70	750	1150	2000	3000	3500	5'	3'	170	15000	13000	94	2.97	3.50	4.22	10.22	-
TQ 160 2_100	550	850	1600	3000	3500	5'	3'	170	15000	13000	94	2.95	3.48	4.20	10.20	-

S-M-BOR-NL-CAFS-001-V01

TQ

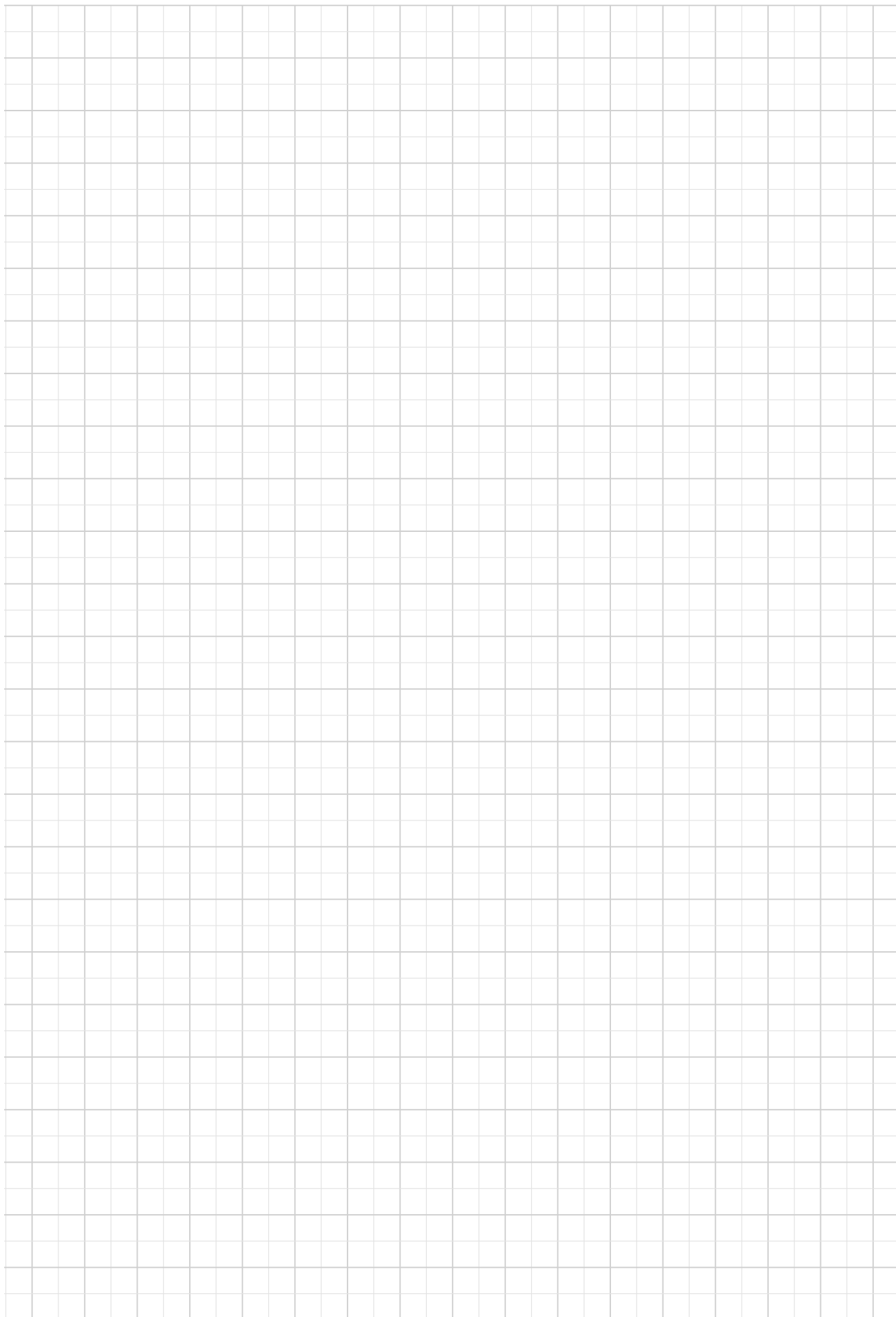

New TQF

PLANETARY PRECISION INLINE FLANGED GEARBOX

TQF features a higher positioning. This planetary gearbox is impressive in many aspects. Ideally suited for high positioning accuracy, highly dynamic cyclic operation and compact solutions.

TQF

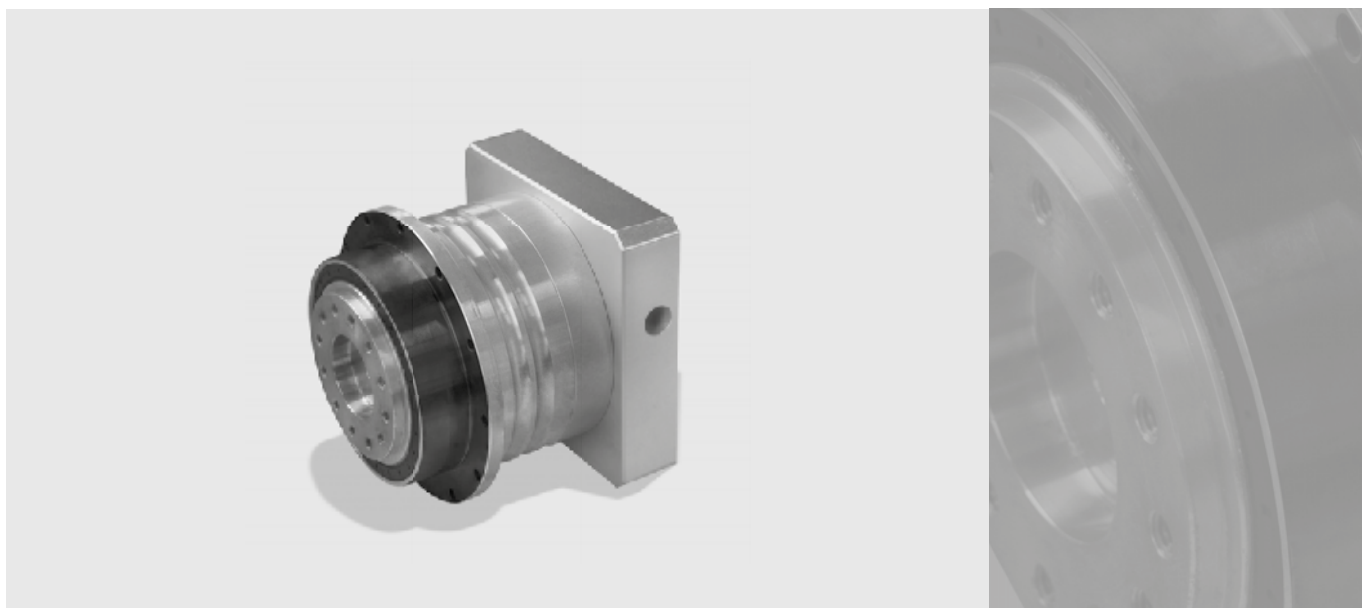

Product Line Up:

- Outstanding Torque Density with a compact design
- Outstanding Acceleration and Nominal Torques
- Highest Radial & Axial Load Capacities
- Highest Tilting Moment and Torsional Stiffness
- Geometrical backlash less than 3 arcmin
- Output flange similar to EN ISO 9409
- Designed for Cyclic and Continuous Duty
- Quiet running
- Universal Design allows any Mounting Orientation

3 FEATURES OF NEW TQF SERIES

Low backlash planetary drives of the TQF series feature a flange on the output shaft and are ideally suited for high positioning accuracy and highly dynamic cyclic operation.

Their design and construction has been developed with the goal of offering a line of product, which features exceptional performance, highest level of stiffness, low backlash and compactness.

TQF

- TQF features two classes of precision, corresponding to the following values of circumferential backlash
1-stage units: standard $\varphi_S \leq 5'$ reduced $\varphi_R \leq 3'$
2-stage units: standard $\varphi_S \leq 7'$ reduced $\varphi_R \leq 5'$
- A high IP rating (IP65) provides inner parts with protection against the ingress of dust and liquids.
- Input section oil seals made from a Fluoroelastomer compound are supplied as standard.
- Noise pressure level $60 \leq L_p \leq 70$ dB(A). Conditions: distance 1 m ; measured without load and an input speed of $n_1 = 3000$ min⁻¹; $i = 10$.
- Numerous adapters allow matching the most popular brands of servomotors.
- Lubrication optimized for the type of duty specified when ordering.
In the absence of contamination the lubricant requires no periodical changes.

duty	TQF 060 ... TQF 160	other seals
S1 (continuous)	Synthetic oil viscosity ISO VG 220	Fluoroelastomer
S5 (intermittent)	NLGI grease consistency 00	NBR

- Ambient temperature min -20°C, max +30°C. For temperature higher than 30°C please consider derating factor f_T .
- Housing temperature must not exceed $T_{max} = 90^\circ\text{C}$.

		Distribution of nominal torque M_{n2} [Nm]												
[i]		4	5	7	10	16	20	25	28	35	40	50	70	100
TQF 060		30	30	25	20	30	30	30	30	30	30	30	25	20
TQF 070		70	70	60	40	70	70	70	70	70	70	70	60	40
TQF 090		200	180	160	110	200	180	180	200	180	200	180	160	110
TQF 130		400	400	360	280	400	400	400	400	400	400	400	360	280
TQF 160		800	800	750	550	800	800	800	800	800	800	800	750	550

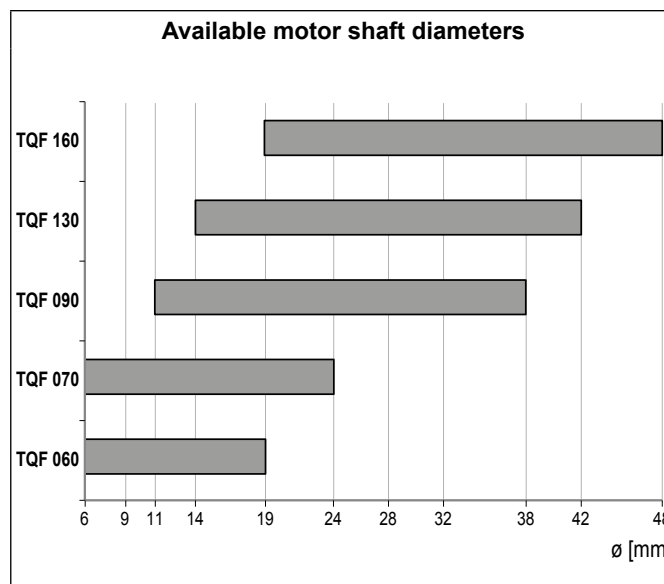
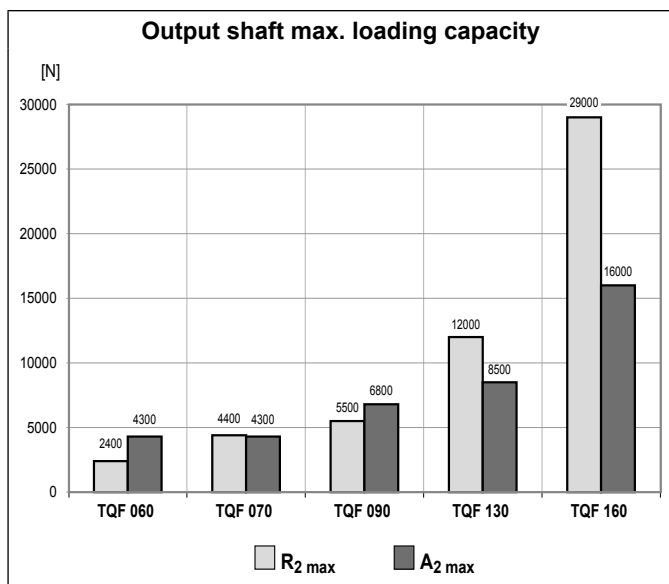

3.1 ORDERING CODE

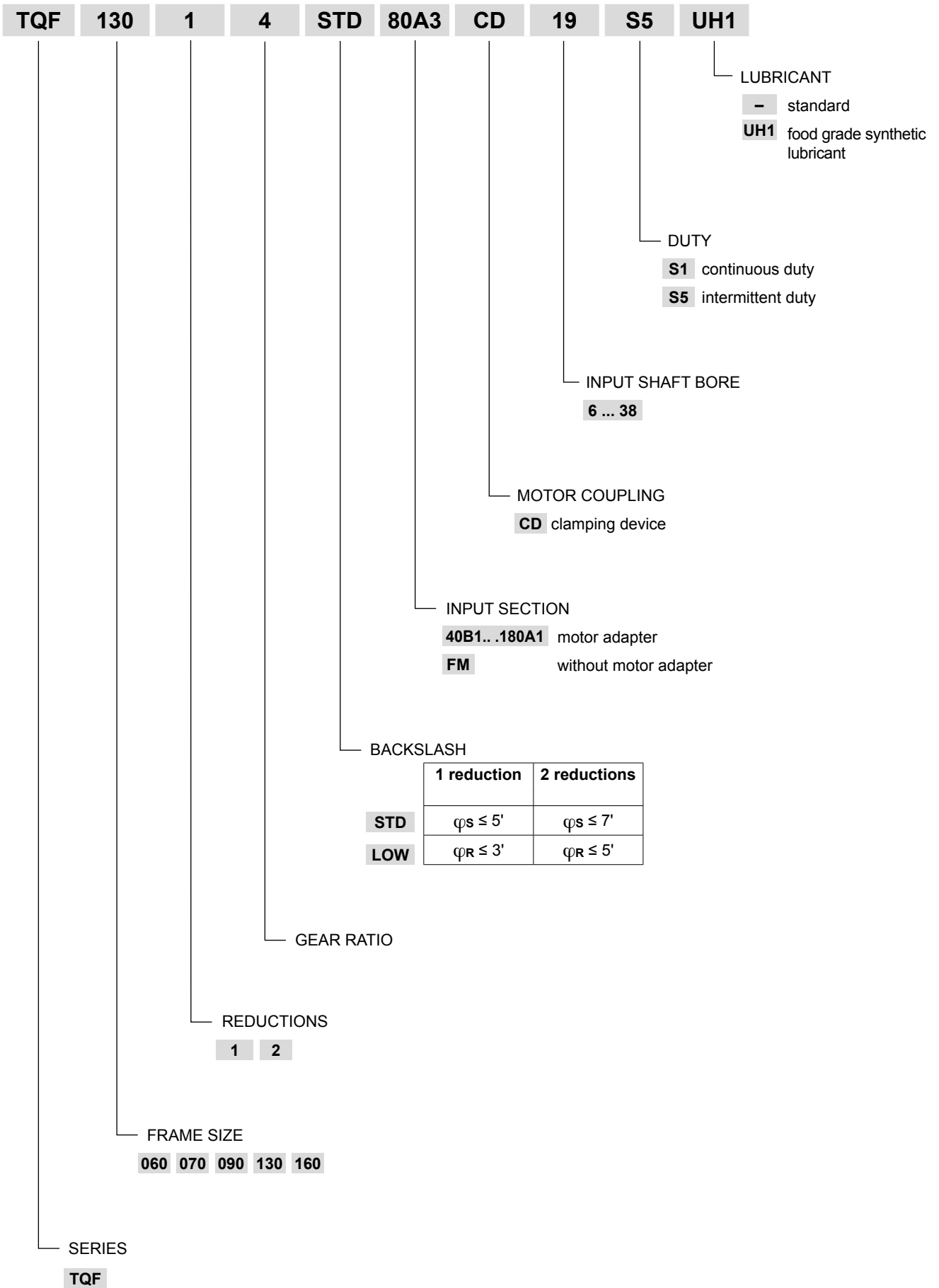

S-M-BOR-NL-CAFS-001-V01

TQF

3.2 DIMENSIONS AND TECHNICAL SPECIFICATIONS

TQF 060

TQF

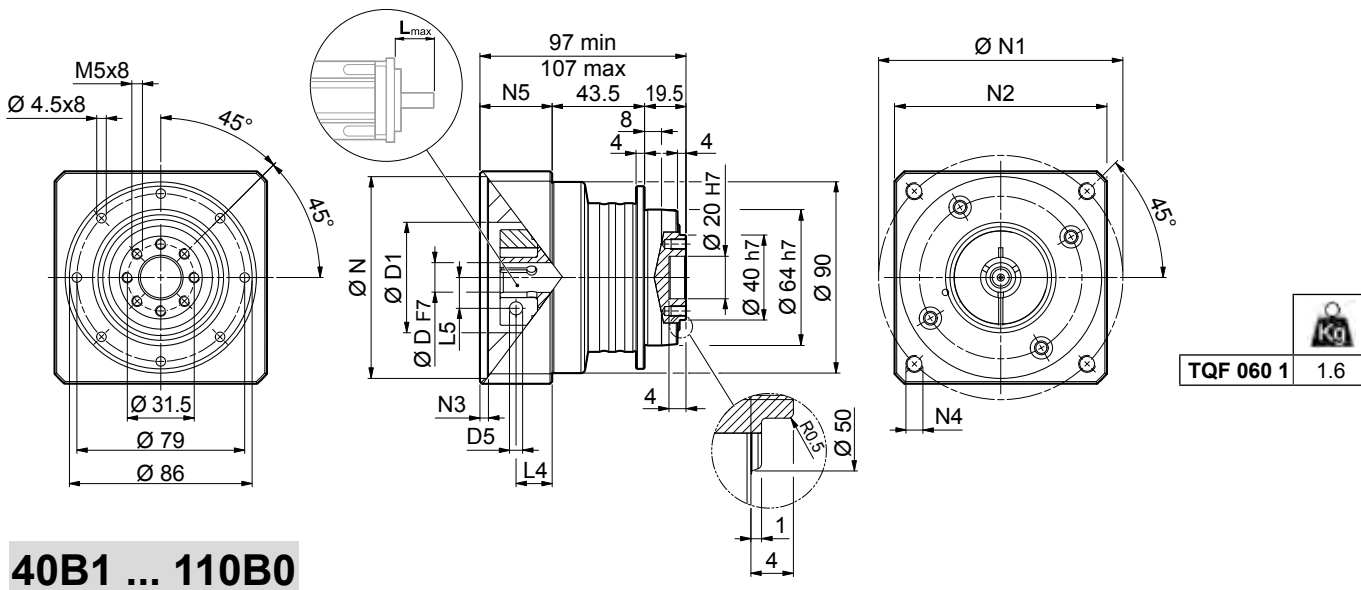

40B1 ... 110B0

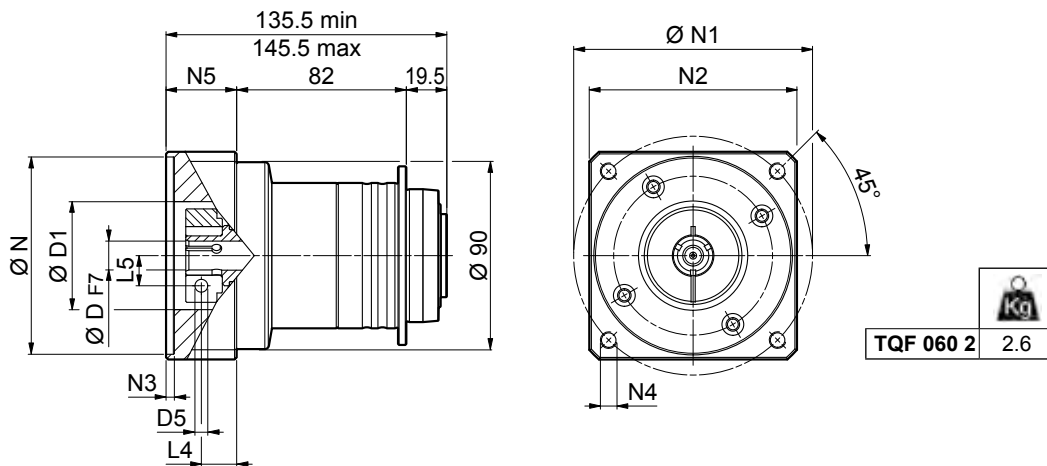

	D					N	N1	N2	N3	N4	N5	L _{max}
												
40B1	6	9	11	14	-	40	63	80	4	M4x12	34	40
50A1	6	9	11	14	-	50	60	80	4	M4x10	34	40
50C1	6	9	11	14	-	50	70	80	4	M4x10	34	40
60A2	6	9	11	14	19	60	75	80	4	M5x16	34	40
70B1	6	9	11	14	19	70	90	80	4	M5x16	34	40
80A1	6	9	11	14	19	80	100	90	4	M6x16	34	40
95A	6	9	11	14	19	95	115	100	6.5	M8x20	34	40
110B0	6	9	11	14	19	110	145	120	6.5	M8x20	44	40

Please contact us for other motor adapters and input shaft bore.

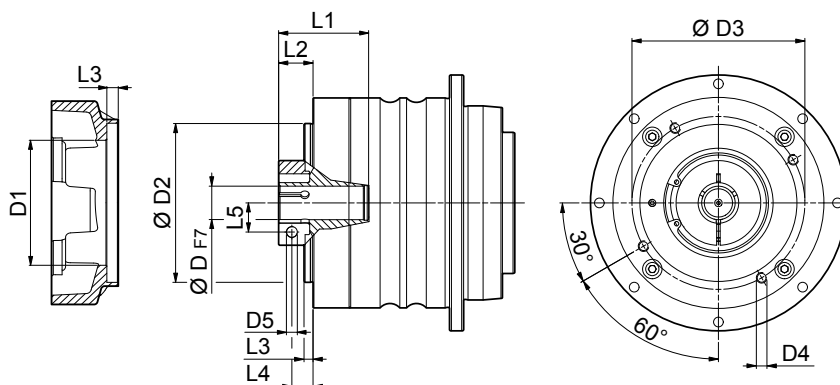

TQF 060

FM

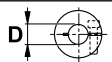

TQF

	D1	D2	D3	D4	D5	L1	L2	L3	L4	L5
6	37	68	76.5	M6x12	M4	31.5	21.5	7.5	16	8
9	49	68	76.5	M6x12	M5	35	24.5	7.5	17	10.5
11	49	68	76.5	M6x12	M6	35	24.5	7.5	17	12.5
14	49	68	76.5	M6x12	M6	35	24.5	7.5	17	14.5
19	54	68	76.5	M6x12	M6	35	24.5	7.5	17	16.5

	M_{n2} [Nm]	M_{a2} [Nm]	M_{p2} [Nm]	n_1 [min ⁻¹]	$n_{1\ max}$ [min ⁻¹]	$\varphi_s \leq \varphi_R$ [arcmin]		C_t [Nm/arcmin]	$R_{2\ max}$ [N]	$A_{2\ max}$ [N]	η %	J_G [kgcm ²]		
						φ_s	φ_R						6 - 9	11 - 14
TQF 060 1_4	30	45	80	3500	6000	5'	3'	12	2400	4300	97	0.32	0.43	0.47
TQF 060 1_5	30	45	80	3500	6000	5'	3'	12	2400	4300	97	0.27	0.39	0.42
TQF 060 1_7	25	38	70	4000	6000	5'	3'	12	2400	4300	97	0.23	0.35	0.38
TQF 060 1_10	20	30	55	4000	6000	5'	3'	12	2400	4300	97	0.21	0.33	0.36
TQF 060 2_16	30	45	80	4500	6000	7'	5'	12	2400	4300	94	0.28	0.39	0.43
TQF 060 2_20	30	45	80	4500	6000	7'	5'	12	2400	4300	94	0.27	0.39	0.42
TQF 060 2_25	30	45	80	4500	6000	7'	5'	12	2400	4300	94	0.25	0.36	0.40
TQF 060 2_28	30	45	80	4500	6000	7'	5'	12	2400	4300	94	0.22	0.34	0.37
TQF 060 2_35	30	45	80	4500	6000	7'	5'	12	2400	4300	94	0.22	0.33	0.37
TQF 060 2_40	30	45	80	4500	6000	7'	5'	12	2400	4300	94	0.21	0.32	0.36
TQF 060 2_50	30	45	80	4500	6000	7'	5'	12	2400	4300	94	0.21	0.32	0.36
TQF 060 2_70	25	38	70	5000	6000	7'	5'	12	2400	4300	94	0.21	0.32	0.36
TQF 060 2_100	20	30	55	5000	6000	7'	5'	12	2400	4300	94	0.21	0.32	0.36

TQF 070

50C2 ... 130A

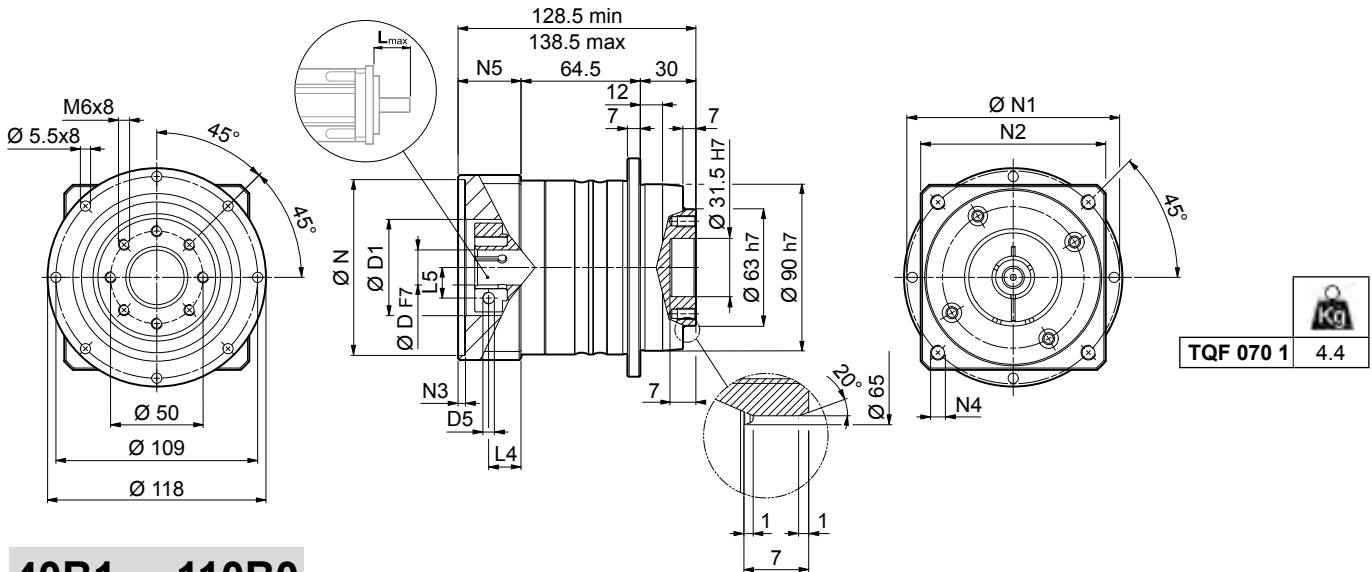

40B1 ... 110B0

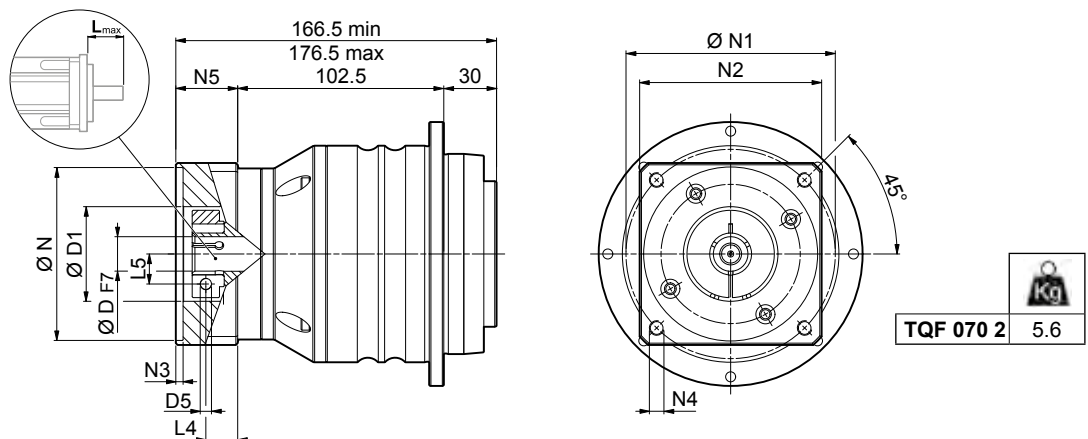

	D						N	N1	N2	N3	N4	N5	L _{max}
TQF 070 1													
50C2	6	9	11	14	-	-	50	70	80	4	M4x10	34	50
60A3	6	9	11	14	19	-	60	75	80	4	M5x16	34	50
70B2	6	9	11	14	19	-	70	90	80	4	M5x16	34	50
80A2	6	9	11	14	19	-	80	100	90	4	M6x16	34	50
95A1	6	9	11	14	19	24	95	115	100	6.5	M8x20	34	50
110A1	6	9	11	14	19	24	110	130	115	6.5	M8x20	34	50
110B1	6	9	11	14	19	24	110	145	120	6.5	M8x20	44	60
130A	6	9	11	14	19	24	130	165	140	6.5	M10x19	34	50
TQF 070 2													
40B1	6	9	11	14	-	-	40	63	80	4	M4x12	34	40
50A1	6	9	11	14	-	-	50	60	80	4	M4x10	34	40
50C1	6	9	11	14	-	-	50	70	80	4	M4x10	34	40
60A2	6	9	11	14	19	-	60	75	80	4	M5x16	34	40
70B1	6	9	11	14	19	-	70	90	80	4	M5x16	34	40
80A1	6	9	11	14	19	-	80	100	90	4	M6x16	34	40
95A	6	9	11	14	19	-	95	115	100	6.5	M8x20	34	40
110B0	6	9	11	14	19	-	110	145	120	6.5	M8x20	44	40

Please contact us for other motor adapters and input shaft bore.

TQF 070

FM

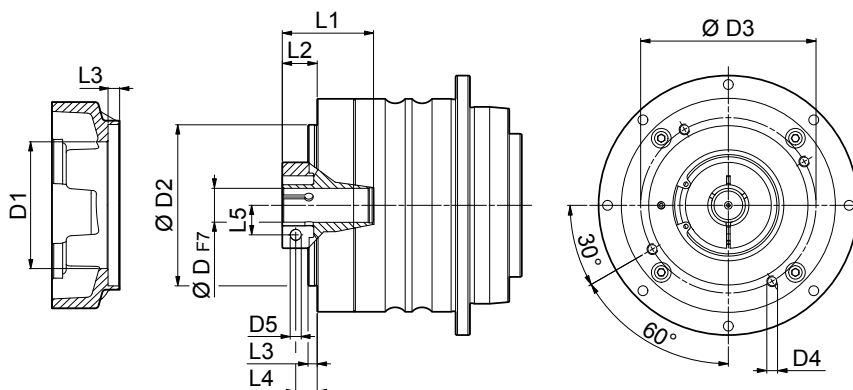

TQF

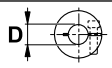
	D1	D2	D3	D4	D5	L1	L2	L3	L4	L5
TQF 070 1										
6	37	68	76.5	M6x14	M4	45	23	9	19	8
9	49	68	76.5	M6x14	M5	42	26	9	18.5	10.5
11	51	68	76.5	M6x14	M6	42	25	9	17.5	12.5
14	51	68	76.5	M6x14	M6	42	25	9	17.5	14.5
19	51	68	76.5	M6x14	M6	42	25	9	17.5	16.5
24	60	68	76.5	M6x14	M6	43.5	26.5	9	17.5	19
TQF 070 2										
6	37	68	76.5	M6x12	M4	31.5	21.5	7.5	16	8
9	49	68	76.5	M6x12	M5	35	24.5	7.5	17	10.5
11	49	68	76.5	M6x12	M6	35	24.5	7.5	17	12.5
14	49	68	76.5	M6x12	M6	35	24.5	7.5	17	14.5
19	54	68	76.5	M6x12	M6	35	24.5	7.5	17	16.5

	M_{n2}	M_{a2}	M_{p2}	n_1	$n_1 \text{ max}$	$\varphi_s \leq \varphi_R$		C_t	$R_{2 \text{ max}}$	$A_{2 \text{ max}}$	η	$J_G \text{ [kgcm}^2\text{]}$			
						[Nm]	[Nm]					[Nm]	[min ⁻¹]	[min ⁻¹]	[arcmin]
TQF 070 1_4	70	100	180	3000	6000	5'	3'	29	4400	4300	97	-	1.05	1.09	1.22
TQF 070 1_5	70	100	180	3000	6000	5'	3'	29	4400	4300	97	-	0.85	0.88	1.01
TQF 070 1_7	60	90	160	3500	6000	5'	3'	29	4400	4300	97	-	0.68	0.71	0.85
TQF 070 1_10	40	60	110	3500	6000	5'	3'	29	4400	4300	97	-	0.59	0.62	0.75
TQF 070 2_16	70	100	180	3500	6000	7'	5'	29	4400	4300	94	0.31	0.43	0.46	-
TQF 070 2_20	70	100	180	3500	6000	7'	5'	29	4400	4300	94	0,30	0.41	0.45	-
TQF 070 2_25	70	100	180	3500	6000	7'	5'	29	4400	4300	94	0.26	0.37	0.41	-
TQF 070 2_28	70	100	180	3500	6000	7'	5'	29	4400	4300	94	0.23	0.35	0.38	-
TQF 070 2_35	70	100	180	3500	6000	7'	5'	29	4400	4300	94	0.23	0.34	0.38	-
TQF 070 2_40	70	100	180	3500	6000	7'	5'	29	4400	4300	94	0.21	0.33	0.36	-
TQF 070 2_50	70	100	180	3500	6000	7'	5'	29	4400	4300	94	0.21	0.32	0.36	-
TQF 070 2_70	60	90	160	4000	6000	7'	5'	29	4400	4300	94	0.21	0.32	0.36	-
TQF 070 2_100	40	60	110	4500	6000	7'	5'	29	4400	4300	94	0.21	0.32	0.36	-

TQF 090

60A4 ... 180A

TQF

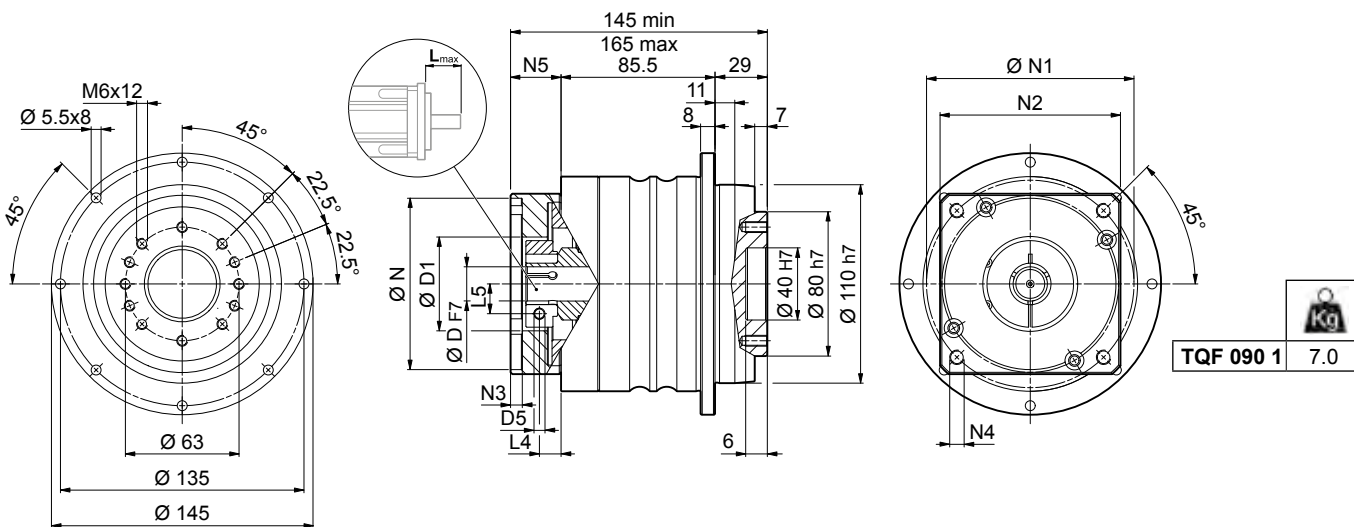

50C2 ... 130A

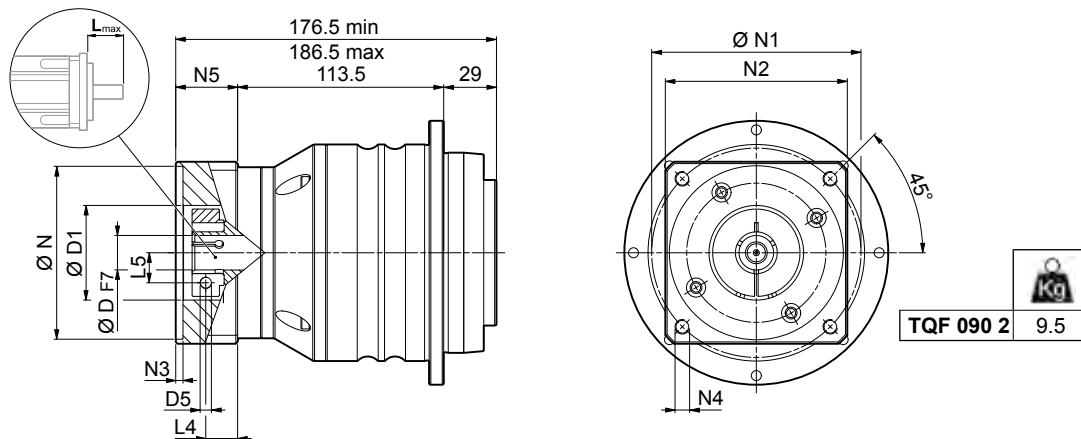

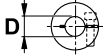
							N	N1	N2	N3	N4	N5	L _{max}
TQF 090 1													
60A4	11	14	19	-	-	-	60	75	100	6.5	M5x14	28	60
80A3	11	14	19	-	-	-	80	100	100	6.5	M6x16	28	60
95A2	11	14	19	24	28	-	95	115	100	6.5	M8x18	28	60
110A2	11	14	19	24	-	-	110	130	115	6.5	M8x18	28	60
110B1	11	14	19	24	28	-	110	145	120	6.5	M8x20	38	60
130A1	11	14	19	24	28	32	130	165	140	6.5	M10x25	38	60
180A	11	14	19	24	28	32	180	215	190	6.5	M14x28	48	80
TQF 090 2													
50C2	11	14	-	-	-	-	50	70	80	4	M4x10	34	50
60A3	11	14	19	-	-	-	60	75	80	4	M5x16	34	50
70B2	11	14	19	-	-	-	70	90	80	4	M5x16	34	50
80A2	11	14	19	-	-	-	80	100	90	4	M6x16	34	50
95A1	11	14	19	24	-	-	95	115	100	6.5	M8x20	34	50
110A1	11	14	19	24	-	-	110	130	115	6.5	M8x20	34	50
110B1	11	14	19	24	-	-	110	145	120	6.5	M8x20	44	60
130A	11	14	19	24	-	-	130	165	140	6.5	M10x19	34	50

Please contact us for other motor adapters and input shaft bore.

TQF 090

FM

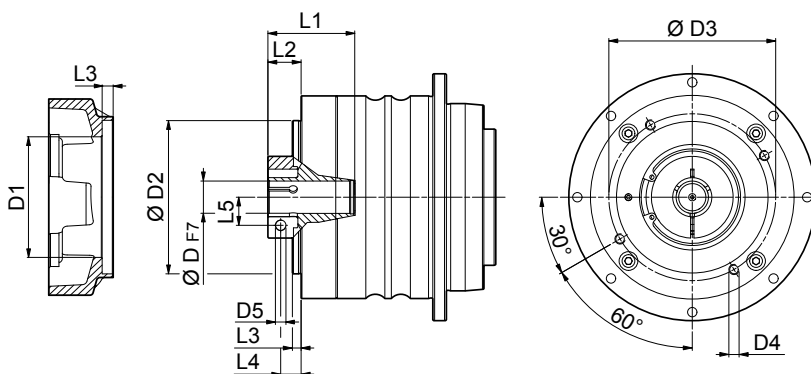

TQF

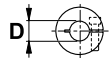
	D1	D2	D3	D4	D5	L1	L2	L3	L4	L5
TQF 090 1										
11	49	90	98	M6x12	M6	50	17	4	9.5	12.5
14	51	90	98	M6x12	M6	50	17	4	9.5	14.5
19	51	90	98	M6x12	M6	50	17	4	9.5	16.5
24	60	90	98	M6x12	M6	51.5	18.5	4	9.5	19
28	72	90	98	M6x12	M8	51.5	18.5	4	9.5	22.5
32	72	90	98	M6x12	M8	51.5	18.5	5	12	24.5
38	80	90	98	M6x12	M8	51.5	18.5	5	12	28
TQF 090 2										
6	37	68	76.5	M6x14	M4	45	23	9	19	8
9	49	68	76.5	M6x14	M5	42	26	9	18.5	10.5
11	51	68	76.5	M6x14	M6	42	25	9	17.5	12.5
14	51	68	76.5	M6x14	M6	42	25	9	17.5	14.5
19	51	68	76.5	M6x14	M6	42	25	9	17.5	16.5
24	60	68	76.5	M6x14	M6	43.5	25	9	17.5	19

	M_{n2}	M_{a2}	M_{p2}	n_1	$n_{1\max}$	$\varphi_s \leq \varphi_R$		C_t	$R_{2\max}$	$A_{2\max}$	η	J_G [kgcm ²]				
						[Nm]	[Nm]					[Nm]	[min ⁻¹]	[min ⁻¹]	[arcmin]	[arcmin]
TQF 090 1_4	200	300	500	2500	4500	5'	3'	70	5500	6800	97	-	2,00	2.12	2.51	4,30
TQF 090 1_5	180	280	500	2500	4500	5'	3'	70	5500	6800	97	-	1.63	1.76	2.14	3.94
TQF 090 1_7	160	250	500	3000	4500	5'	3'	70	5500	6800	97	-	1.31	1.44	1.82	3.62
TQF 090 1_10	110	170	350	3000	4500	5'	3'	70	5500	6800	97	-	1.14	1.27	1.65	3.45
TQF 090 2_16	200	300	500	3000	4500	7'	5'	70	5500	6800	94	0.75	0.85	0.98	-	-
TQF 090 2_20	180	280	500	3000	4500	7'	5'	70	5500	6800	94	0.72	0.82	0.96	-	-
TQF 090 2_25	180	280	500	3000	4500	7'	5'	70	5500	6800	94	0.62	0.72	0.85	-	-
TQF 090 2_28	200	300	500	3000	4500	7'	5'	70	5500	6800	94	0.54	0.64	0.77	-	-
TQF 090 2_35	180	280	500	3000	4500	7'	5'	70	5500	6800	94	0.53	0.63	0.76	-	-
TQF 090 2_40	200	300	500	3000	4500	7'	5'	70	5500	6800	94	0.49	0.59	0.72	-	-
TQF 090 2_50	180	280	500	3500	4500	7'	5'	70	5500	6800	94	0.48	0.58	0.72	-	-
TQF 090 2_70	160	250	500	4000	4500	7'	5'	70	5500	6800	94	0.48	0.58	0.71	-	-
TQF 090 2_100	110	170	350	4000	4500	7'	5'	70	5500	6800	94	0.48	0.58	0.71	-	-

TQF 130

80A3 ... 180A1

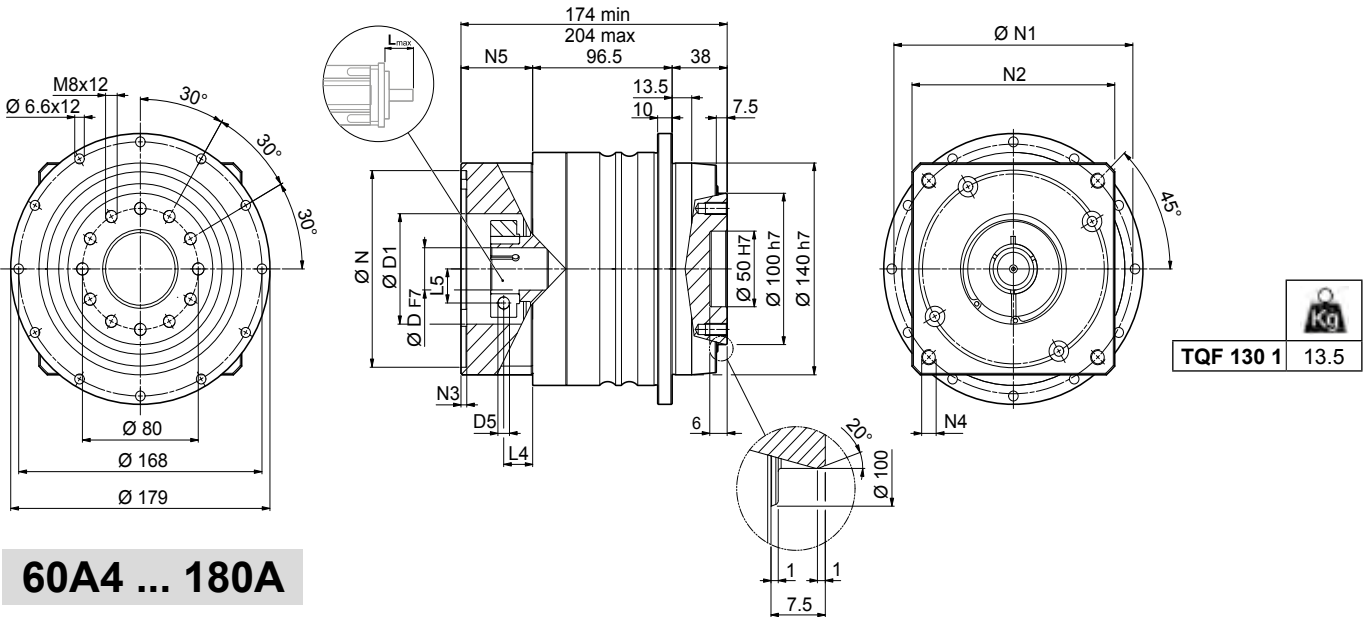

60A4 ... 180A

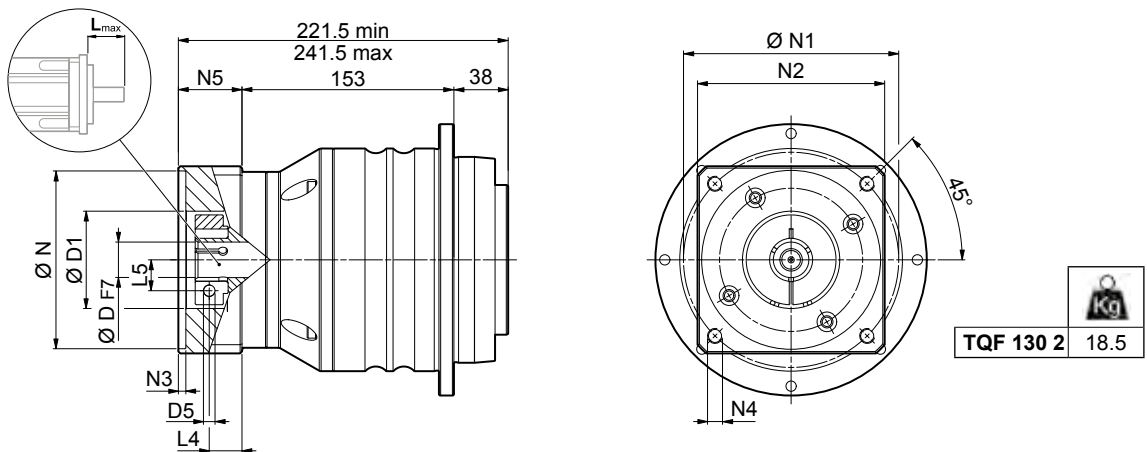
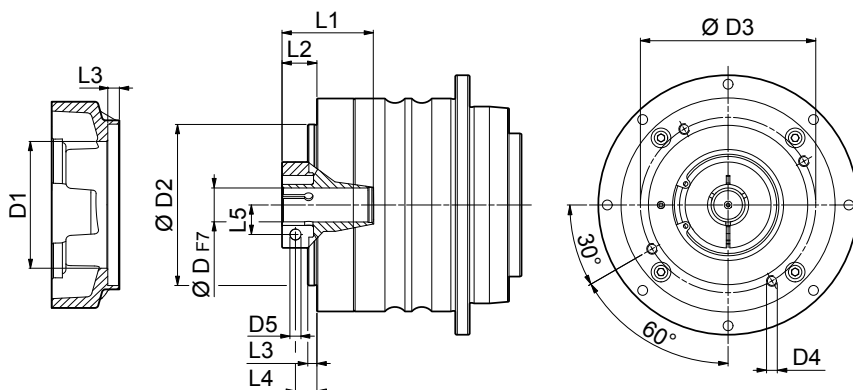

Image	D						N	N1	N2	N3	N4	N5	L _{max}
	1	2	3	4	5	6							
TQF 130 1													
80A3	14	19	-	-	-	-	80	100	130	4	M6x15	39.5	60
95A2	14	19	24	28	-	-	95	115	130	6.5	M8x20	39.5	60
110A2	14	19	24	-	-	-	110	130	130	4	M8x20	39.5	60
110B1	14	19	24	28	-	-	110	145	130	6.5	M8x20	49.5	60
130A1	14	19	24	28	32	-	130	165	140	4	M10x20	39	60
180A	14	19	24	28	32	38	180	215	190	5.5	M14x25	49.5	60
180A1	14	19	24	28	32	38	180	215	190	5.5	M14x25	69.5	80
TQF 130 2													
60A4	14	19	-	-	-	-	60	75	100	6.5	M5x14	28	60
80A3	14	19	-	-	-	-	80	100	100	6.5	M6x16	28	60
95A2	14	19	24	28	-	-	95	115	100	6.5	M8x18	28	60
110A2	14	19	24	-	-	-	110	130	115	6.5	M8x18	28	60
110B1	14	19	24	28	-	-	110	145	120	6.5	M8x20	38	60
130A1	14	19	24	28	32	-	130	165	140	6.5	M10x25	38	60
180A	14	19	24	28	32	-	180	215	190	6.5	M14x28	48	80

Please contact us for other motor adapters and input shaft bore.

TQF 130

FM

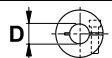

TQF

	D1	D2	D3	D4	D5	L1	L2	L3	L4	L5
TQF 130 1										
14	51	113	125.5	M8x16	M6	50	30.5	5	23	14.5
19	54	113	125.5	M8x16	M6	50	27.5	5	20	16.5
24	70	113	125.5	M8x16	M6	51.5	29	5	20	19
28	70	113	125.5	M8x16	M8	51.5	29	5	20	22.5
32	72	113	125.5	M8x16	M8	51.5	29	5	20	24.5
38	100	113	125.5	M8x16	M8	54	31.5	5	20	28
42	114	113	125.5	M8x16	M10	51.5	35	5	20	33
TQF 130 2										
11	49	90	98	M6x12	M6	50	17	4	9.5	12.5
14	51	90	98	M6x12	M6	50	17	4	9.5	14.5
19	51	90	98	M6x12	M6	50	17	4	9.5	16.5
24	60	90	98	M6x12	M6	51.5	18.5	4	9.5	19
28	72	90	98	M6x12	M8	51.5	18.5	4	9.5	22.5
32	72	90	98	M6x12	M8	51.5	18.5	5	12	24.5
38	80	90	98	M6x12	M8	51.5	18.5	5	12	28

	M_{n2}	M_{a2}	M_{p2}	n_1	$n_1 \max$	$\varphi_S \leq \varphi_R$		C_t	$R_2 \max$	$A_2 \max$	η	J_G [kgcm ²]				
						[Nm]	[Nm]					[Nm]	[min ⁻¹]	[min ⁻¹]	[arcmin]	[Nm/arcmin]
TQF 130 1_4	400	600	1000	2100	4000	5'	3'	180	12000	8500	97	-	8.14	8.61	9.25	15.25
TQF 130 1_5	400	600	1000	2500	4000	5'	3'	180	12000	8500	97	-	6.13	6.59	7.24	13.24
TQF 130 1_7	360	550	950	2500	4000	5'	3'	180	12000	8500	97	-	4,40	4.86	5,50	11,50
TQF 130 1_10	280	420	900	2500	4000	5'	3'	180	12000	8500	97	-	3.43	3.89	4.53	10.53
TQF 130 2_16	400	600	1000	2800	4000	7'	5'	180	12000	8500	94	1.89	2.05	3.71	3.71	-
TQF 130 2_20	400	600	1000	2800	4000	7'	5'	180	12000	8500	94	1.77	1.92	3.58	3.58	-
TQF 130 2_25	400	600	1000	2800	4000	7'	5'	180	12000	8500	94	1.47	1.63	3.29	3.29	-
TQF 130 2_28	400	600	1000	2800	4000	7'	5'	180	12000	8500	94	1.26	1.41	3.07	3.07	-
TQF 130 2_35	400	600	1000	2800	4000	7'	5'	180	12000	8500	94	1.22	1.37	3.03	3.03	-
TQF 130 2_40	400	600	1000	3200	4000	7'	5'	180	12000	8500	94	1,10	1.25	2.91	2.91	-
TQF 130 2_50	400	600	1000	3200	4000	7'	5'	180	12000	8500	94	1.08	1.23	2.89	2.89	-
TQF 130 2_70	360	550	950	3500	4000	7'	5'	180	12000	8500	94	1.06	1.22	2.88	2.88	-
TQF 130 2_100	280	420	900	4000	4000	7'	5'	180	12000	8500	94	1.05	1.21	2.87	2.87	-

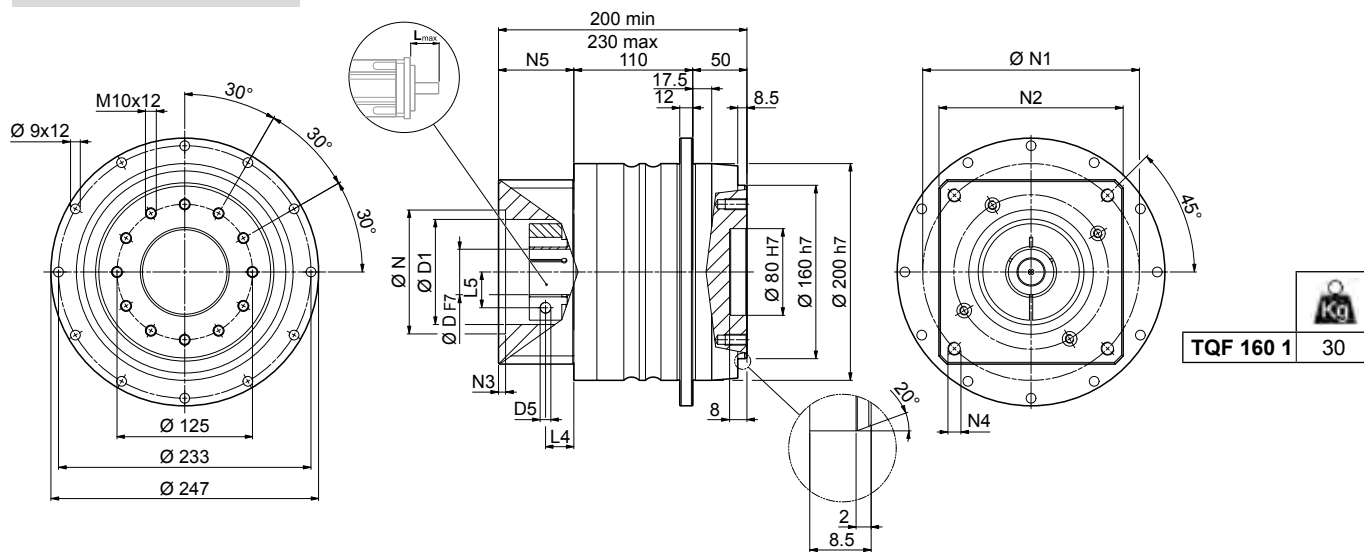

TQF 160

95A2 ... 180A1

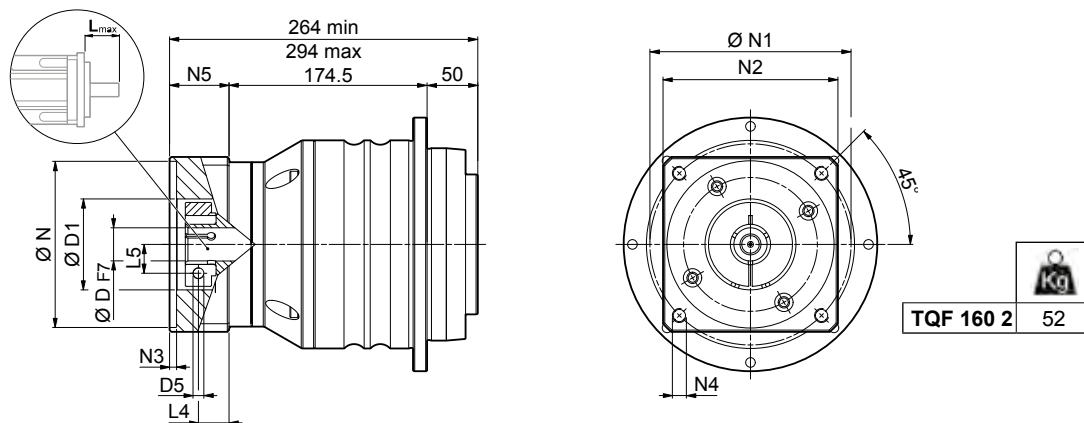

80A3 ... 180A1



												
	D					N	N1	N2	N3	N4	N5	L _{max}
TQF 160 1												
95A2	19	24	28	-	-	95	115	140	6.5	M8x20	39.5	60
110A2	19	24	-	-	-	110	130	140	5	M8x20	39.5	60
130A1	19	24	28	32	-	130	165	140	5	M10x20	39.5	60
180A	-	24	28	32	-	180	215	190	6.5	M14x25	49.5	60
180A1	19	24	28	32	38	180	215	190	6.5	M14x25	69.5	80
TQF 160 2												
80A3	19	-	-	-	-	80	100	130	4	M6x15	39.5	60
95A2	19	24	28	-	-	95	115	130	6.5	M8x20	39.5	60
110A2	19	24	-	-	-	110	130	130	4	M8x20	39.5	60
110B1	19	24	28	-	-	110	145	130	6.5	M8x20	49.5	60
130A1	19	24	28	32	-	130	165	140	4	M10x20	39	60
180A	19	24	28	32	-	180	215	190	5.5	M14x25	49.5	60
180A1	19	24	28	32	38	180	215	190	5.5	M14x25	69.5	80

Please contact us for other motor adapters and input shaft bore.

TQF 160

FM

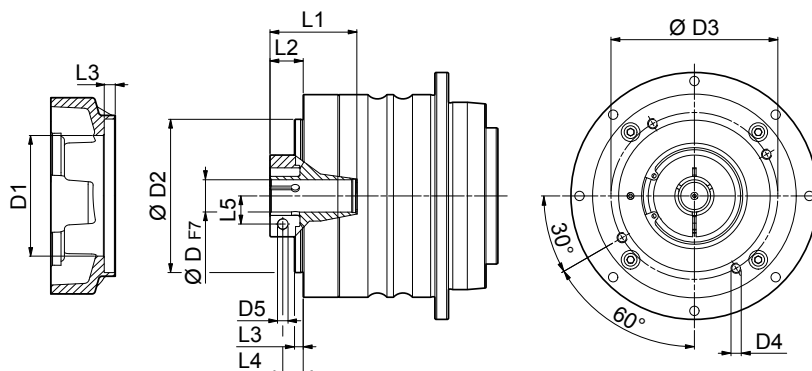

TQF

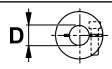
	D1	D2	D3	D4	D5	L1	L2	L3	L4	L5
TQF 160 1										
19	54	130	142.5	M8x16	M6	47	33.5	8	26	16.5
24	58	130	142.5	M8x16	M6	47	35	8	26	19
28	70	130	142.5	M8x16	M8	47	35	8	26	22.5
32	72	130	142.5	M8x16	M8	47	35	8	26	24.5
38	100	130	142.5	M8x16	M8	59.5	37.5	8	26	28
42	114	130	142.5	M8x16	M10	57	41	8	26	33
48	125	130	142.5	M8x16	M12	57	41	8	26	36.5
TQF 160 2										
14	51	113	125.5	M8x16	M6	50	30.5	5	23	14.5
19	54	113	125.5	M8x16	M6	50	27.5	5	20	16.5
24	70	113	125.5	M8x16	M6	51.5	29	5	20	19
28	70	113	125.5	M8x16	M8	51.5	29	5	20	22.5
32	72	113	125.5	M8x16	M8	51.5	29	5	20	24.5
38	100	113	125.5	M8x16	M8	54	31.5	5	20	28
42	114	113	125.5	M8x16	M10	51.5	35	5	20	33

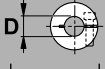
	M_{n2}	M_{a2}	M_{p2}	n_1	$n_{1\max}$	$\varphi_S \varphi_R$		C_t	$R_{2\max}$	$A_{2\max}$	η	J_G [kgcm ²]				
						\leq	\leq									
i	[Nm]	[Nm]	[Nm]	[min ⁻¹]	[min ⁻¹]	[arcmin]	[arcmin]	[Nm/arcmin]	[N]	[N]	%	19	24 - 28	32 - 38	42	48
TQF 160 1_4	800	1200	2000	1500	3500	5'	3'	500	29000	16000	97	-	27,10	27.51	30,40	43.51
TQF 160 1_5	800	1200	2000	1800	3500	5'	3'	500	29000	16000	97	-	18.22	18.63	21.52	34.63
TQF 160 1_7	750	1150	2000	2500	3500	5'	3'	500	29000	16000	97	-	13.46	13.87	16.77	29.88
TQF 160 1_10	550	850	1600	2500	3500	5'	3'	500	29000	16000	97	-	10.03	10.44	13.34	26.45
TQF 160 2_16	800	1200	2000	2800	3500	7'	5'	500	29000	16000	94	7.22	7.75	8.47	14.47	-
TQF 160 2_20	800	1200	2000	2800	3500	7'	5'	500	29000	16000	94	6.67	7,20	7.92	13.92	-
TQF 160 2_25	800	1200	2000	2800	3500	7'	5'	500	29000	16000	94	5.13	5.66	6.38	12.38	-
TQF 160 2_28	800	1200	2000	2800	3500	7'	5'	500	29000	16000	94	4,00	4.53	5.25	11.25	-
TQF 160 2_35	800	1200	2000	2800	3500	7'	5'	500	29000	16000	94	3.82	4.34	5.07	11.07	-
TQF 160 2_40	800	1200	2000	2800	3500	7'	5'	500	29000	16000	94	3.16	3.69	4.41	10.41	-
TQF 160 2_50	800	1200	2000	2800	3500	7'	5'	500	29000	16000	94	3.07	3,60	4.32	10.32	-
TQF 160 2_70	750	1150	2000	3000	3500	7'	5'	500	29000	16000	94	3.02	3.55	4.27	10.27	-
TQF 160 2_100	550	850	1600	3000	3500	7'	5'	500	29000	16000	94	2.99	3.52	4.24	10.24	-

TQF

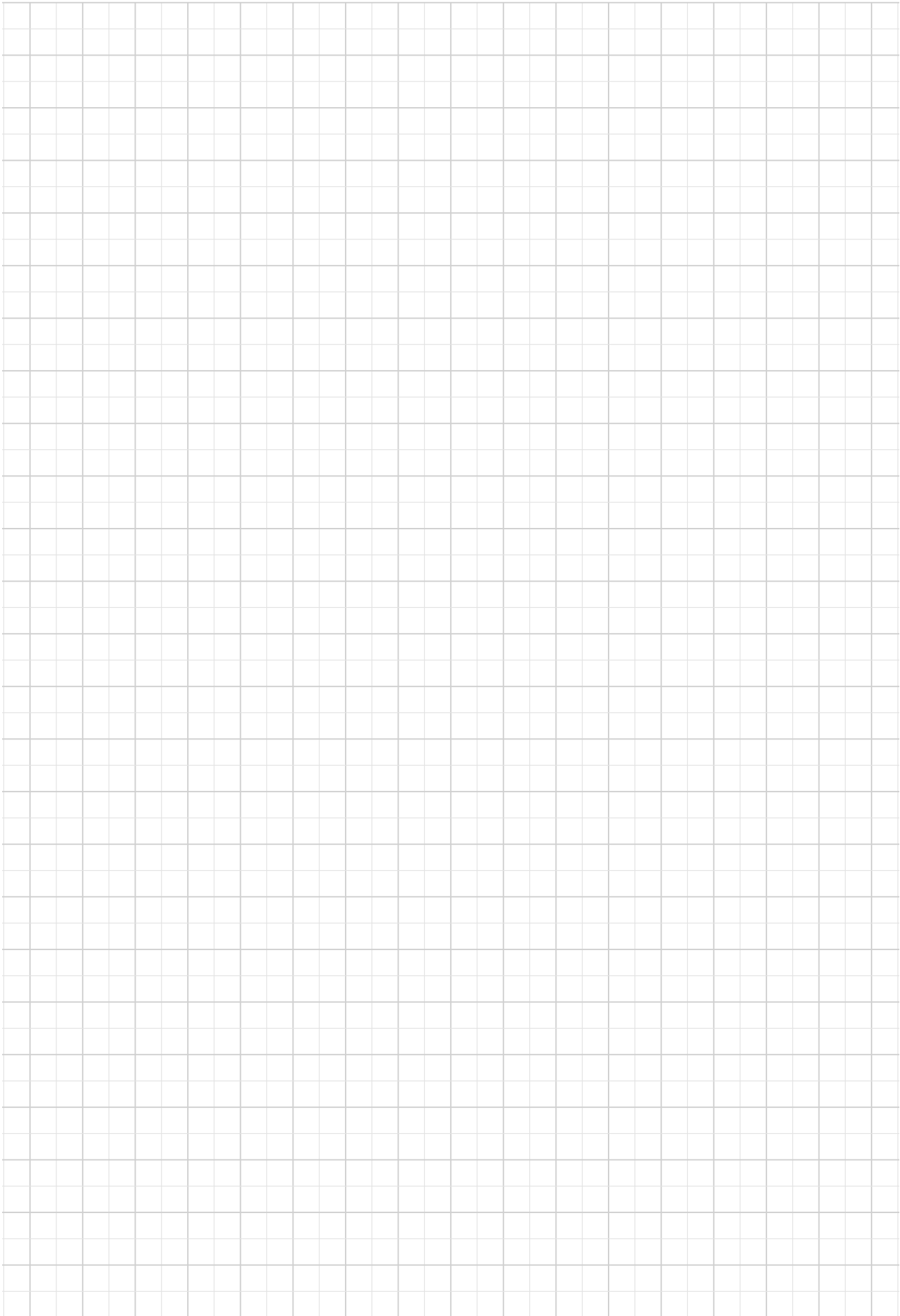

TQK

PLANETARY PRECISION RIGHT ANGLE GEARBOX

TQK angular gearbox features a higher positioning like TQ inline serie.

This exceptional gearbox is the solution to space problems often posed by increasingly compact machines.

Whether torque, robustness, or precision - this attractive product range scores in every category.

TQK



Product Line Up:

- Outstanding Torque Density
- Outstanding Acceleration and Nominal Torques
- Outstanding Radial and Axial Load Capacities
- Designed for Cyclic and Continuous Duty
- Markedly high Torsional Stiffness
- Geometrical Backlash less than 4 arcmin
- Quiet Running
- Universal Design allows any Mounting Orientation

4 FEATURES OF TQK SERIES

Low backlash bevel-planetary drives of the TQK series are the solution to space problems often posed by increasingly compact machines. TQK drives combine high levels of dynamic operation with top precision, which results in great accuracy and repeatability for any positioning mechanism in which they are installed.

On top of their robustness and dependability TQK drives also feature a distinctive Italian style that makes them clearly recognizable amongst like products within the reference industry.

- TQK features two classes of precision, corresponding to the following values of circumferential backlash
2-stage units: standard $\varphi_S \leq 5'$; reduced $\varphi_R \leq 4'$ ($\varphi_S \leq 6'$; $\varphi_R \leq 5'$ for TQK 060 and TQK 070)
3-stage units: standard $\varphi_S \leq 7'$; reduced $\varphi_R \leq 6'$ ($\varphi_S \leq 8'$; $\varphi_R \leq 7'$ for TQK 060 and TQK 070)
- A high IP rating (IP65) provides inner parts with protection against the ingress of dust and liquids.
- Input section oil seals made from a Fluoroelastomer compound are supplied as standard.
- Noise pressure level $60 \leq L_p \leq 70$ dB(A). Conditions: distance 1 m ; measured without load and an input speed of $n_1 = 3000 \text{ min}^{-1}$; $i = 20$.
- Numerous adapters allow matching the most popular brands of servomotors.
- Lubrication optimized for the type of duty specified when ordering, in the absence of contamination the lubricant requires no periodical changes.

duty	TQK 060 ... TQK 160	other seals
S1 (continuous)	Synthetic oil viscosity ISO VG 220	Fluoroelastomer
S5 (intermittent)	NLGI grease consistency 00	NBR

- Ambient temperature min -20°C , max $+30^\circ\text{C}$. For temperature higher than 30°C please consider derating factor f_T .
- Housing temperature must not exceed $T_{\text{max}} = 90^\circ\text{C}$.

		Distribution of nominal torque M_{n2} [Nm]														
[i]		6	8	10	14	18	20	24	30	40	50	70	80	100	140	200
TQK 060		21	28	30	25	21	20	30	30	30	30	30	30	30	25	20
TQK 070		45	60	70	60	45	40	70	70	70	70	70	70	70	60	40
TQK 090		110	150	180	160	130	110	200	180	180	180	180	200	180	160	110
TQK 130		255	340	400	360	260	280	400	400	400	400	400	400	400	360	280
TQK 160		420	560	700	750	530	550	800	800	800	800	800	800	800	750	550

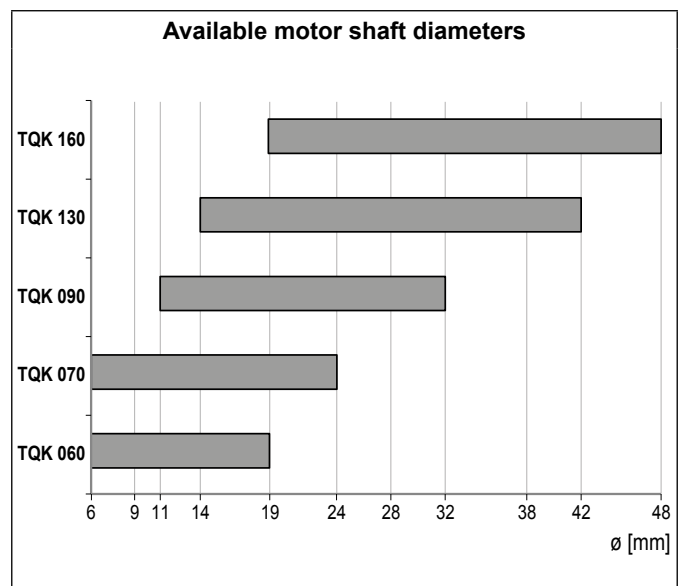
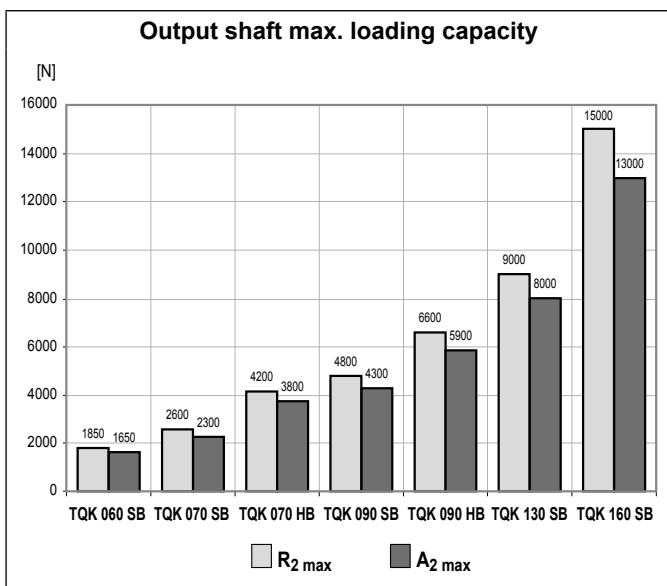

4.1 ORDERING CODE

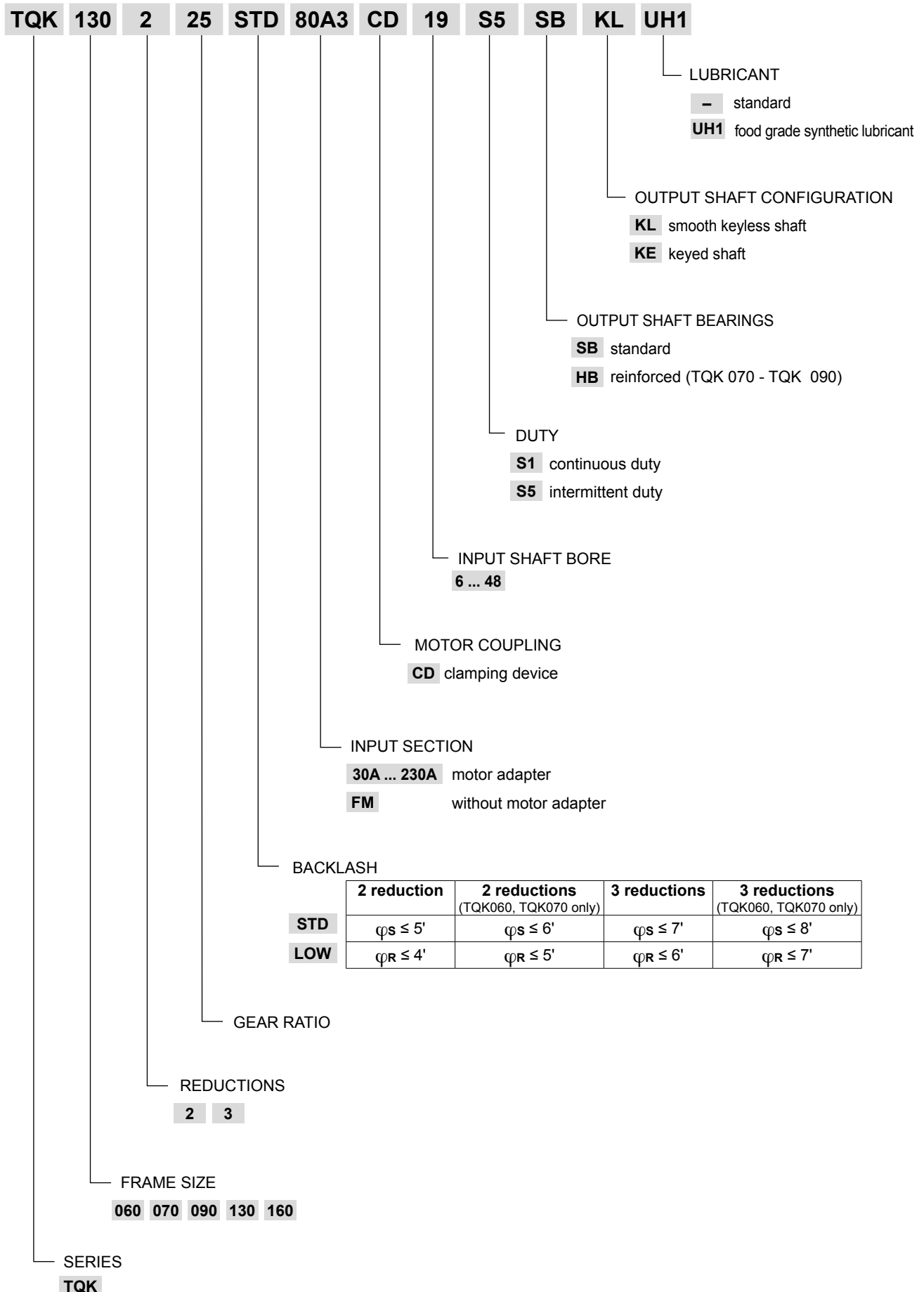

TQK

4.2 DIMENSIONS AND TECHNICAL SPECIFICATIONS

TQK 060

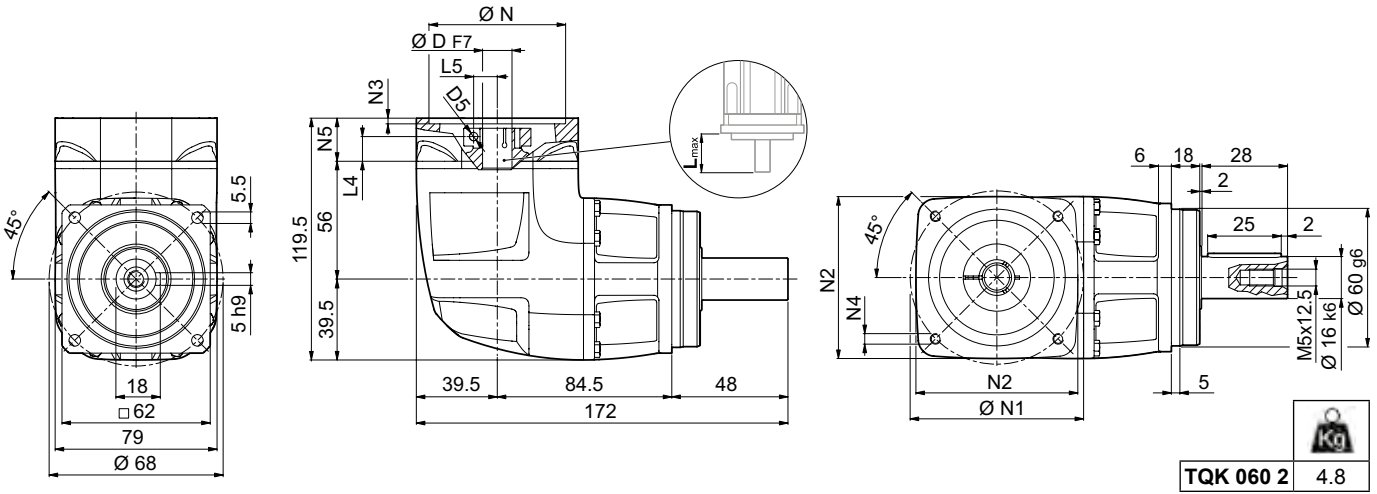

30A ... 110B0

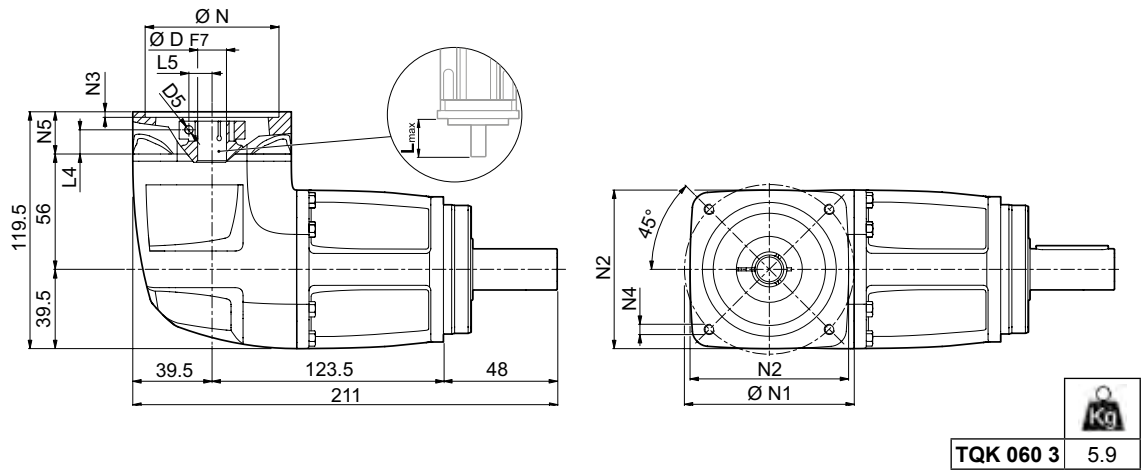

						N	N1	N2	N3	N4	N5	L _{max}
	30A	6	-	-	-	30	46	60	3.5	M4x10	24	40
	40B1	6	9	11	14	40	63	60	3.5	M4x10	24	40
	50A1	6	9	11	14	50	60	60	4.0	M4x10	24	40
	50C1	6	9	11	14	50	70	60	4.0	M4x10	24	40
	60A2	6	9	11	14	60	75	80	4.0	M5x12	24	40
	70B1	6	9	11	14	70	90	80	4.0	M5x12	24	40
	80A1	6	9	11	14	80	100	100	4.0	M6x14	24	40
	95A	6	9	11	14	95	115	100	4.0	M8x24*	24	40
	110B0	6	9	11	14	110	145	120	4.0	M8x24*	24	40



* through hole. Please contact us for other motor adapters and input shaft bore.

TQK 060

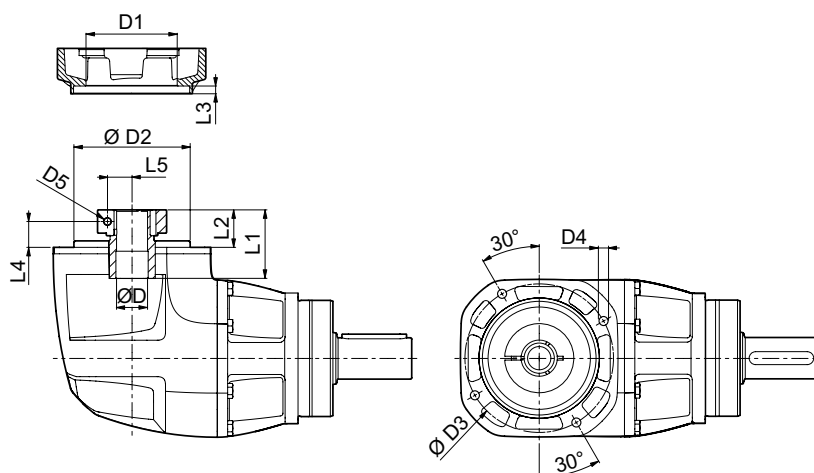
FM

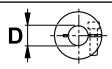

	D1	D2	D3	D4	D5	L1	L2	L3	L4	L5
6	37	59	72	M5x11	M4	31.5	15.5	4.5	10.5	8
9	49	59	72	M5x11	M5	35	19	4.5	11.5	10.5
11	49	59	72	M5x11	M6	35	19	4.5	11.5	12.5
14	49	59	72	M5x11	M6	35	19	4.5	11.5	14.5
19	54	59	72	M5x11	M6	35	19	4.5	11.5	16.5

	i	M _{n 2} [Nm]	M _{a 2} [Nm]	M _{p 2} [Nm]	n ₁ [min ⁻¹]	n _{1 max} [min ⁻¹]	φ _S ≤ [arcmin]	φ _R [arcmin]	C _t [Nm/arcmin]	R _{2 max} [N]	A _{2 max} [N]	η %	J _G [kgcm ²]		
														6 - 9	11 - 14
TQK 060 2_6		21	30	45	2500	5000	6'	5'	4.3	1850	1650	94	0.76	0.78	0.78
TQK 060 2_8		28	40	60	2500	5000	6'	5'	4.3	1850	1650	94	0.75	0.76	0.77
TQK 060 2_10		30	45	70	2500	5000	6'	5'	4.3	1850	1650	94	0.73	0.75	0.75
TQK 060 2_14		25	38	70	2500	5000	6'	5'	4.3	1850	1650	94	0.72	0.73	0.74
TQK 060 2_20		20	30	55	2500	5000	6'	5'	4.3	1850	1650	94	0.71	0.72	0.73
TQK 060 3_18		21	32	60	2500	5000	8'	7'	4.3	1850	1650	91	0.61	0.62	0.63
TQK 060 3_24		30	45	80	2500	5000	8'	7'	4.3	1850	1650	91	0.61	0.62	0.63
TQK 060 3_30		30	45	80	2500	5000	8'	7'	4.3	1850	1650	91	0.60	0.62	0.62
TQK 060 3_40		30	45	80	2500	5000	8'	7'	4.3	1850	1650	91	0.60	0.61	0.62
TQK 060 3_50		30	45	80	2500	5000	8'	7'	4.3	1850	1650	91	0.60	0.61	0.62
TQK 060 3_70		30	45	80	2500	5000	8'	7'	4.3	1850	1650	91	0.60	0.61	0.62
TQK 060 3_80		30	45	80	2500	5000	8'	7'	4.3	1850	1650	91	0.60	0.61	0.62
TQK 060 3_100		30	45	80	2500	5000	8'	7'	4.3	1850	1650	91	0.59	0.61	0.61
TQK 060 3_140		25	38	70	2500	5000	8'	7'	4.3	1850	1650	91	0.59	0.61	0.61
TQK 060 3_200		20	30	55	2500	5000	8'	7'	4.3	1850	1650	91	0.59	0.61	0.61

TQK

TQK 070

50C2 ... 130A

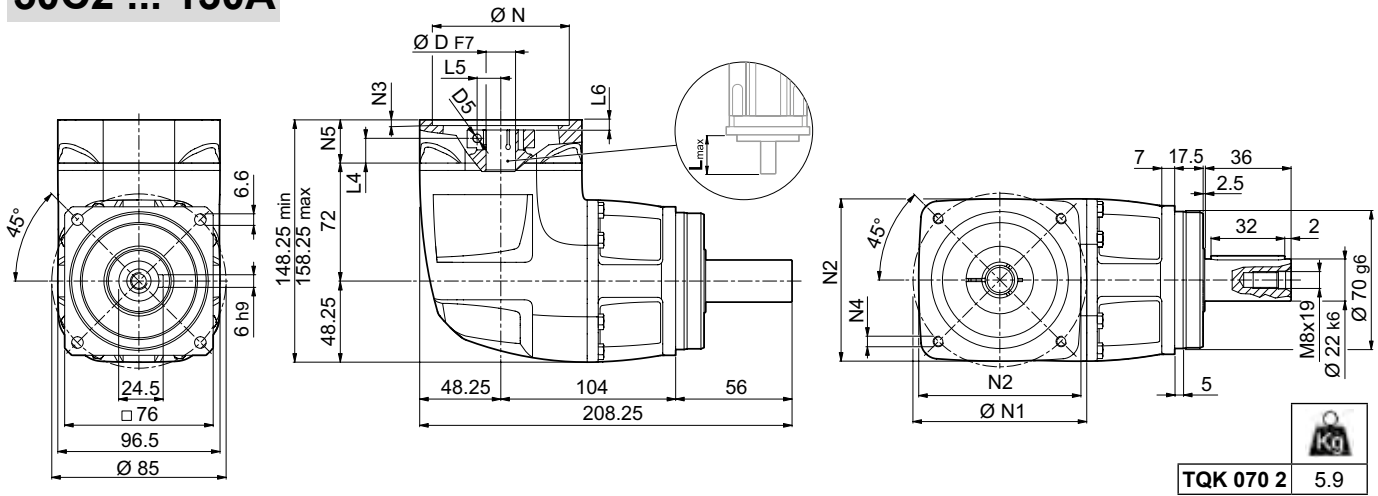

TQK 070 2 5.9

30A ... 110B0

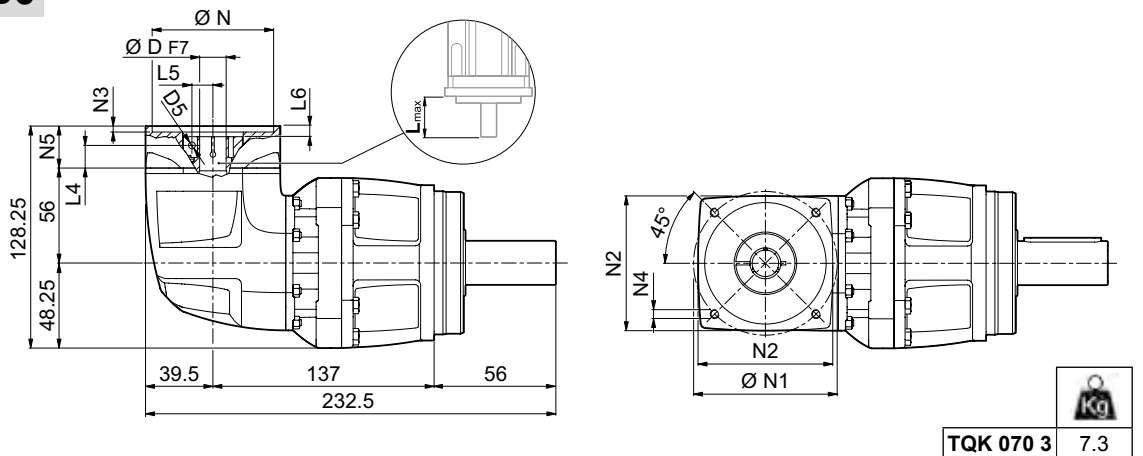

TQK 070 3 7.3

	D						N	N1	N2	N3	N4	N5	L _{max}
TQK 070 2													
50C2	6	9	11	14	-	-	50	70	80	6.5	M4x12	28	50
60A3	6	9	11	14	19	-	60	75	80	6.5	M5x14	28	50
70B2	6	9	11	14	19	-	70	90	80	6.5	M5x14	28	50
80A2	6	9	11	14	19	-	80	100	100	6.5	M6x14	28	50
95A1	6	9	11	14	19	24	95	115	100	6.5	M8x18	28	50
110A1	6	9	11	14	19	24	110	130	120	6.5	M8x18	28	50
110B1	6	9	11	14	19	24	110	145	120	6.5	M8x20	38	60
130A	6	9	11	14	19	24	130	165	140	6.5	M10x19	28	50
TQK 070 3													
30A	6	-	-	-	-	-	30	46	60	3.5	M4x10	24	40
40B1	6	9	11	14	-	-	40	63	60	3.5	M4x10	24	40
50A1	6	9	11	14	-	-	50	60	60	4.0	M4x10	24	40
50C1	6	9	11	14	-	-	50	70	60	4.0	M4x10	24	40
60A2	6	9	11	14	19	-	60	75	80	4.0	M5x12	24	40
70B1	6	9	11	14	19	-	70	90	80	4.0	M5x12	24	40
80A1	6	9	11	14	19	-	80	100	100	4.0	M6x14	24	40
95A	6	9	11	14	19	-	95	115	100	4.0	M8x24*	24	40
110B0	6	9	11	14	19	-	110	145	120	4.0	M8x24*	24	40

* through hole. Please contact us for other motor adapters and input shaft bore.

TQK 070

FM

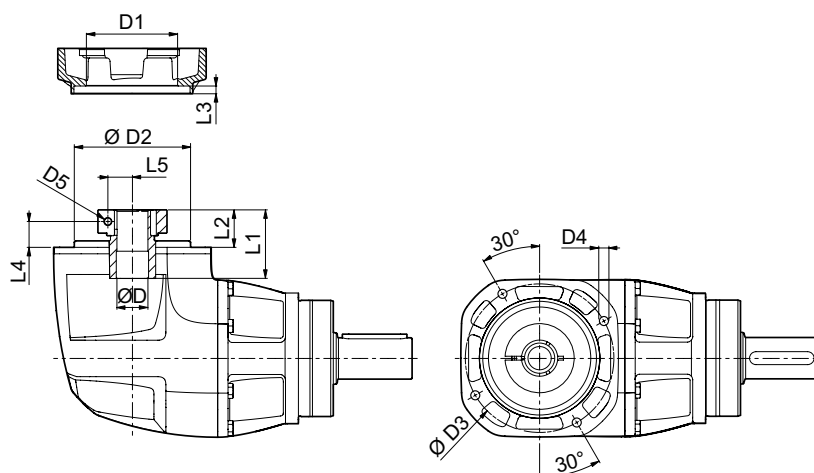

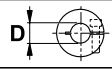
	D1	D2	D3	D4	D5	L1	L2	L3	L4	L5
TQK 070 2										
11	51	70	85	M6x11	M6	42	20	5	12.5	12.5
14	51	70	85	M6x11	M6	42	20	5	12.5	14.5
19	51	70	85	M6x11	M6	42	20	5	12.5	16.5
24	60	70	85	M6x11	M6	43.5	21.5	5	12.5	19
TQK 070 3										
6	37	59	72	M5x11	M4	31.5	15.5	4.5	10.5	8
9	49	59	72	M5x11	M5	35	19	4.5	11.5	10.5
11	49	59	72	M5x11	M6	35	19	4.5	11.5	12.5
14	49	59	72	M5x11	M6	35	19	4.5	11.5	14.5
19	54	59	72	M5x11	M6	35	19	4.5	11.5	16.5

	i	M _{n2} [Nm]	M _{a2} [Nm]	M _{p2} [Nm]	n ₁ [min ⁻¹]	n _{1 max} [min ⁻¹]	φ _s ≤ φ _R		C _t [Nm/arcmin]	SB		HB		η %	J _G [kgcm ²]			
							φ _s [arcmin]	φ _R [arcmin]		R _{2 max} [N]	A _{2 max} [N]	R _{2 max} [N]	A _{2 max} [N]					
															6 - 9	11 - 14	19	24
TQK 070 2_6	45	65	90	2500	5000	6'	5'	11	2600	2300	4200	3800	94	-	1.52	1.55	1.63	
TQK 070 2_8	60	85	120	2500	5000	6'	5'	11	2600	2300	4200	3800	94	-	1.44	1.47	1.55	
TQK 070 2_10	70	100	150	2500	5000	6'	5'	11	2600	2300	4200	3800	94	-	1.41	1.43	1.52	
TQK 070 2_14	60	90	160	2500	5000	6'	5'	11	2600	2300	4200	3800	94	-	1.38	1.41	1.49	
TQK 070 2_20	40	60	110	2500	5000	6'	5'	11	2600	2300	4200	3800	94	-	1.36	1.39	1.48	
TQK 070 3_18	45	65	120	2500	5000	8'	7'	11	2600	2300	4200	3800	91	1.28	1.39	1.42	-	
TQK 070 3_24	70	100	180	2500	5000	8'	7'	11	2600	2300	4200	3800	91	1.26	1.37	1.40	-	
TQK 070 3_30	70	100	180	2500	5000	8'	7'	11	2600	2300	4200	3800	91	1.25	1.36	1.39	-	
TQK 070 3_40	70	100	180	2500	5000	8'	7'	11	2600	2300	4200	3800	91	1.20	1.31	1.34	-	
TQK 070 3_50	70	100	180	2500	5000	8'	7'	11	2600	2300	4200	3800	91	1.19	1.31	1.33	-	
TQK 070 3_70	70	100	180	2500	5000	8'	7'	11	2600	2300	4200	3800	91	1.18	1.29	1.32	-	
TQK 070 3_80	70	100	180	2500	5000	8'	7'	11	2600	2300	4200	3800	91	1.17	1.29	1.31	-	
TQK 070 3_100	70	100	180	2500	5000	8'	7'	11	2600	2300	4200	3800	91	1.17	1.28	1.31	-	
TQK 070 3_140	60	90	160	2500	5000	8'	7'	11	2600	2300	4200	3800	91	1.16	1.27	1.30	-	
TQK 070 3_200	40	60	110	2500	5000	8'	7'	11	2600	2300	4200	3800	91	1.15	1.27	1.29	-	

S-M-BOR-NL-CAFS-001-V01

TQK

TQK 090

60A4 ... 180A1

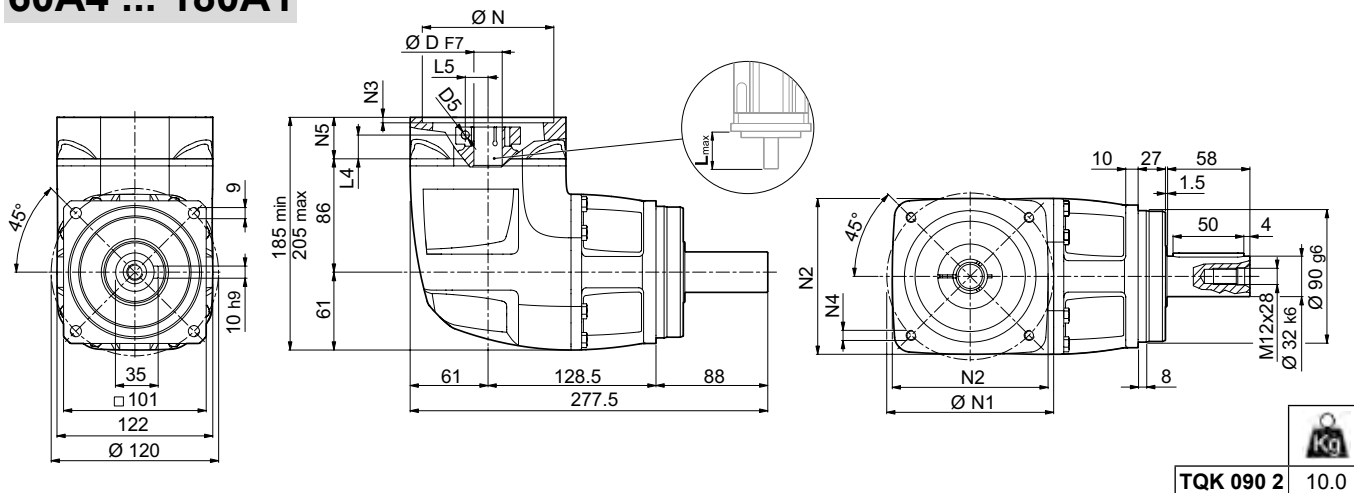

50C2 ... 130A

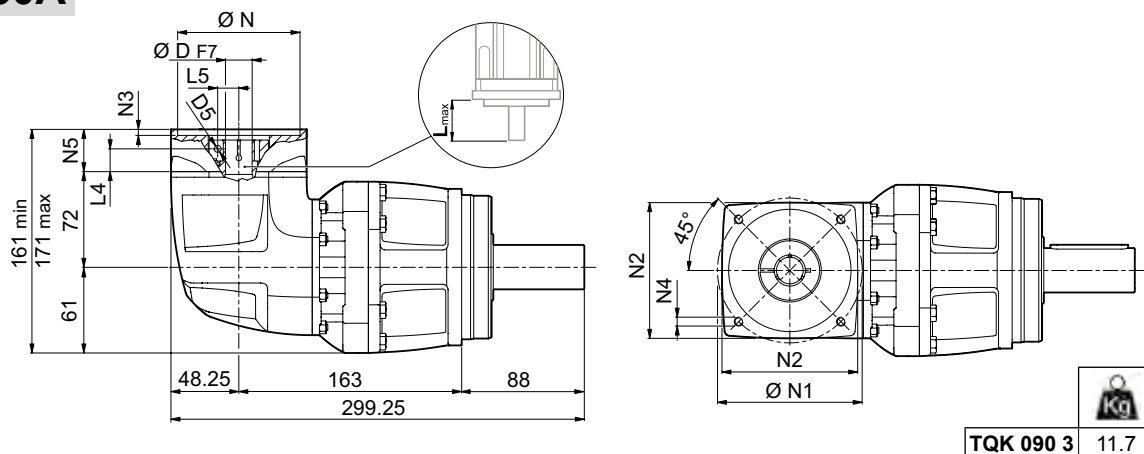

	D						N	N1	N2	N3	N4	N5	L _{max}
TQK 090 2													
60A4	11	14	19	–	–	–	60	75	100	6.5	M5x14	38	60
80A3	11	14	19	–	–	–	80	100	100	6.5	M6x14	38	60
95A2	11	14	19	24	28	–	95	115	100	6.5	M8x18	38	60
110A2	11	14	19	24	–	–	110	130	122	6.5	M8x20	38	60
110B1	11	14	19	24	28	–	110	145	122	6.5	M8x20	38	60
130A1	11	14	19	24	28	32	130	165	140	6.5	M10x20	38	60
180A	11	14	19	24	28	32	180	215	190	6.5	M14x38*	38	60
180A1	11	14	19	24	28	32	180	215	190	6.5	M14x28	58	80
TQK 090 3													
50C2	11	14	–	–	–	–	50	70	80	6.5	M4x12	28	50
60A3	11	14	19	–	–	–	60	75	80	6.5	M5x14	28	50
70B2	11	14	19	–	–	–	70	90	80	6.5	M5x14	28	50
80A2	11	14	19	–	–	–	80	100	100	6.5	M6x14	28	50
95A1	11	14	19	24	–	–	95	115	100	6.5	M8x18	28	50
110A1	11	14	19	24	–	–	110	130	120	6.5	M8x18	28	50
110B1	11	14	19	24	–	–	110	145	120	6.5	M8x20	38	60
130A	11	14	19	24	–	–	130	165	140	6.5	M10x19	28	50

* through hole. Please contact us for other motor adapters and input shaft bore.

TQK 090

FM

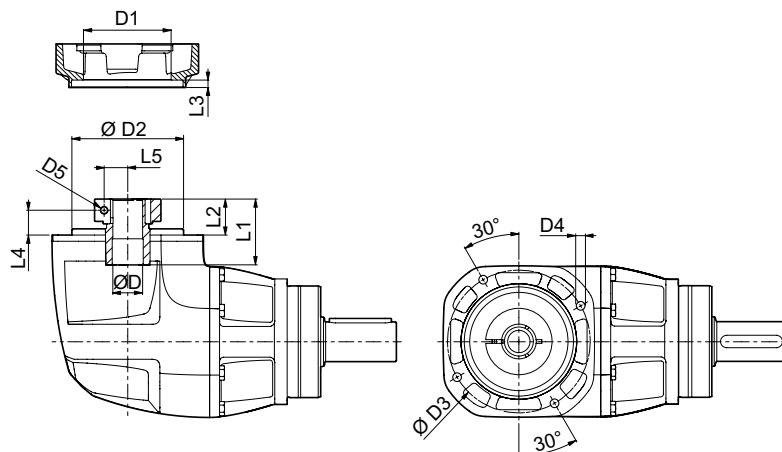

	D1	D2	D3	D4	D5	L1	L2	L3	L4	L5
TQK 090 2										
14	51	90	115	M8x13	M6	50	28	6.5	20.5	14.5
19	51	90	115	M8x13	M6	50	28	6.5	20.5	16.5
24	60	90	115	M8x13	M6	51.5	29.5	6.5	20.5	19
28	72	90	115	M8x13	M8	51.5	29.5	6.5	20.5	22.5
32	72	90	115	M8x13	M8	51.5	29.5	6.5	20.5	24.5
38	80	90	115	M8x13	M8	51.5	29.5	6.5	20.5	28
TQK 090 3										
11	51	70	85	M6x11	M6	42	20	5	12.5	12.5
14	51	70	85	M6x11	M6	42	20	5	12.5	14.5
19	51	70	85	M6x11	M6	42	20	5	12.5	16.5
24	60	70	85	M6x11	M6	43.5	21.5	5	12.5	19

	i	M _{n2} [Nm]	M _{a2} [Nm]	M _{p2} [Nm]	n ₁ [min ⁻¹]	n _{1 max} [min ⁻¹]	φ _S ≤ φ _R [arcmin]	C _t [Nm/arcmin]	SB		HB		η %	J _e [kgcm ²]			
									R _{2 max} [N]	A _{2 max} [N]	R _{2 max} [N]	A _{2 max} [N]		11	14	19 - 24	28 - 32
TQK 090 2_6		110	150	225	2000	4500	5' 4'	28	4800	4300	6600	5900	94	-	4.82	4.89	5.42
TQK 090 2_8		150	208	300	2000	4500	5' 4'	28	4800	4300	6600	5900	94	-	4.56	4.63	5.16
TQK 090 2_10		180	260	360	2000	4500	5' 4'	28	4800	4300	6600	5900	94	-	4.45	4.51	5.04
TQK 090 2_14		160	250	500	2000	4500	5' 4'	28	4800	4300	6600	5900	94	-	4.34	4.41	4.94
TQK 090 2_20		110	170	350	2000	4500	5' 4'	28	4800	4300	6600	5900	94	-	4.29	4.36	4.88
TQK 090 3_18		130	200	400	2000	4500	7' 6'	28	4800	4300	6600	5900	91	3.56	3.63	3.70	-
TQK 090 3_24		200	300	500	2000	4500	7' 6'	28	4800	4300	6600	5900	91	3.53	3.60	3.67	-
TQK 090 3_30		180	280	500	2000	4500	7' 6'	28	4800	4300	6600	5900	91	3.52	3.59	3.66	-
TQK 090 3_40		180	280	500	2000	4500	7' 6'	28	4800	4300	6600	5900	91	3.45	3.52	3.58	-
TQK 090 3_50		180	280	500	2000	4500	7' 6'	28	4800	4300	6600	5900	91	3.42	3.49	3.56	-
TQK 090 3_70		180	280	500	2000	4500	7' 6'	28	4800	4300	6600	5900	91	3.40	3.46	3.53	-
TQK 090 3_80		200	300	500	2000	4500	7' 6'	28	4800	4300	6600	5900	91	3.38	3.45	3.52	-
TQK 090 3_100		180	280	500	2000	4500	7' 6'	28	4800	4300	6600	5900	91	3.38	3.45	3.52	-
TQK 090 3_140		160	250	500	2000	4500	7' 6'	28	4800	4300	6600	5900	91	3.38	3.45	3.52	-
TQK 090 3_200		110	170	350	2000	4500	7' 6'	28	4800	4300	6600	5900	91	3.38	3.45	3.52	-

S-M-BOR-NL-CAFS-001-V01

TQK

TQK 130

80A3 ... 200A

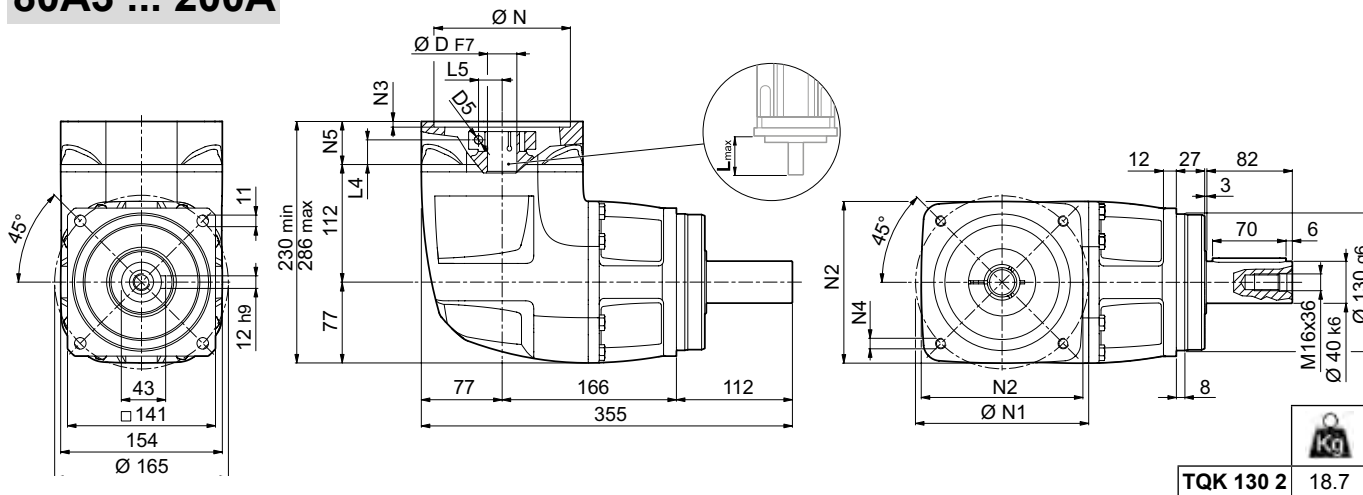

60A4 ... 180A1

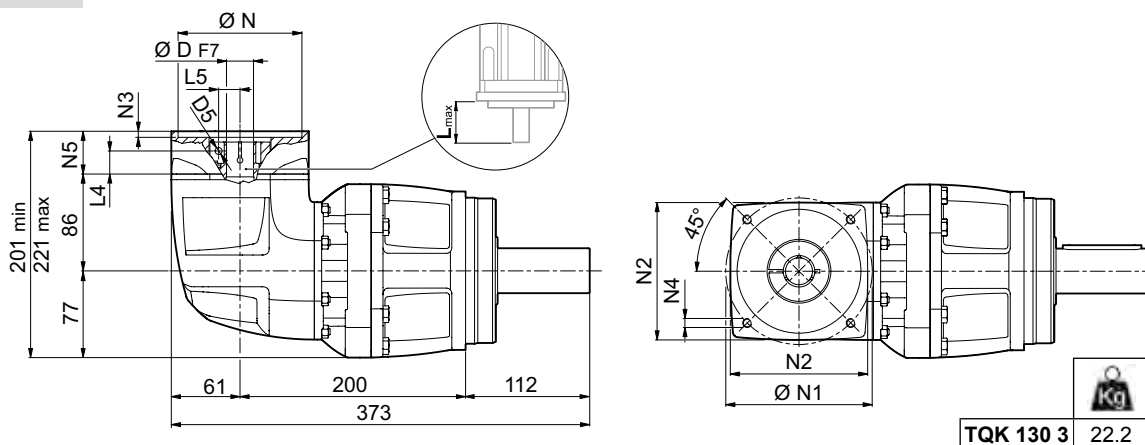

Motor Model	Dimensions (mm)							N	N1	N2	N3	N4	N5	L _{max}
	D	Ø N	Ø D F7	L5	D5	N3	N5							
TQK 130 2														
80A3	14	19	-	-	-	-	80	100	130	6.5	M6x14	41	60	
95A2	14	19	24	28	-	-	95	115	130	6.5	M8x18	41	60	
110A2	14	19	24	-	-	-	110	130	130	6.5	M8x20	41	60	
110B1	14	19	24	28	-	-	110	145	130	6.5	M8x20	41	60	
130A1	14	19	24	28	32	-	130	165	154	6.5	M10x20	41	60	
180A	14	19	24	28	32	-	180	215	190	6.5	M14x28	41	60	
180A1	14	19	24	28	32	38	180	215	190	6.5	M14x28	61	80	
200A	14	19	24	28	32	38	200	235	210	6.5	M14x28	97	110	
TQK 130 3														
60A4	14	19	-	-	-	-	60	75	100	6.5	M5x14	38	60	
80A3	14	19	-	-	-	-	80	100	100	6.5	M6x14	38	60	
95A2	14	19	24	28	-	-	95	115	100	6.5	M8x18	38	60	
110A2	14	19	24	-	-	-	110	130	122	6.5	M8x20	38	60	
110B1	14	19	24	28	-	-	110	145	122	6.5	M8x20	38	60	
130A1	14	19	24	28	32	-	130	165	140	6.5	M10x20	38	60	
180A	14	19	24	28	32	-	180	215	190	6.5	M14x38	38	60	
180A1	14	19	24	28	32	38	180	215	190	6.5	M14x28	58	80	

* through hole. Please contact us for other motor adapters and input shaft bore.

TQK 130

FM

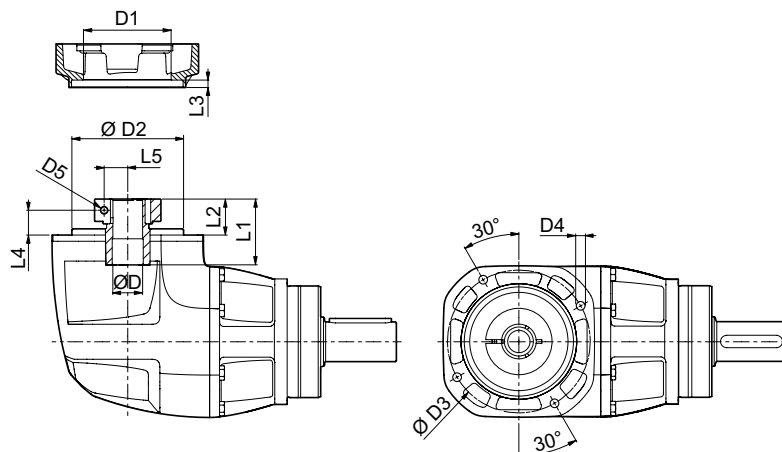

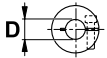
	D1	D2	D3	D4	D5	L1	L2	L3	L4	L5
TQK 130 2										
19	54	120	140	M10x16	M6	50	31	7.5	23.5	16.5
24	70	120	140	M10x16	M6	51.5	32.5	7.5	23.5	19
28	70	120	140	M10x16	M8	51.5	32.5	7.5	23.5	22.5
32	72	120	140	M10x16	M8	51.5	32.5	7.5	23.5	24.5
38	100	120	140	M10x16	M8	54	35	7.5	23.5	28
42	114	120	140	M10x16	M10	51.5	38.5	7.5	23.5	33
TQK 130 3										
14	51	90	115	M8x13	M6	50	28	6.5	20.5	14.5
19	51	90	115	M8x13	M6	50	28	6.5	20.5	16.5
24	60	90	115	M8x13	M6	51.5	29.5	6.5	20.5	19
28	72	90	115	M8x13	M8	51.5	29.5	6.5	20.5	22.5
32	72	90	115	M8x13	M8	51.5	29.5	6.5	20.5	24.5
38	80	90	115	M8x13	M8	51.5	29.5	6.5	20.5	28

	M_{n2}	M_{a2}	M_{p2}	n_1	$n_{1\max}$	φ_s	φ_R	C_t	$R_{2\max}$	$A_{2\max}$	η	J_G [kgcm ²]					
												i	[Nm]	[Nm]	[Nm]	[min ⁻¹]	[min ⁻¹]
TQK 130 2_6	255	360	510	2000	4500	5'	4'	56	9000	8000	94	-	17.44	18.02	18.55	24.47	
TQK 130 2_8	340	480	680	2000	4500	5'	4'	56	9000	8000	94	-	16.31	16.89	17.41	23.33	
TQK 130 2_10	400	600	850	2000	4500	5'	4'	56	9000	8000	94	-	15.77	16.35	16.88	22.80	
TQK 130 2_14	360	550	950	2000	4500	5'	4'	56	9000	8000	94	-	15.35	15.93	16.46	22.38	
TQK 130 2_20	280	420	900	2000	4500	5'	4'	56	9000	8000	94	-	15.13	15.71	16.23	22.15	
TQK 130 3_18	260	400	900	2000	4500	7'	6'	56	9000	8000	91	15.18	15.34	15.92	16.44	-	
TQK 130 3_24	400	600	1000	2000	4500	7'	6'	56	9000	8000	91	15.05	15.21	15.79	16.32	-	
TQK 130 3_30	400	600	1000	2000	4500	7'	6'	56	9000	8000	91	14.99	15.15	15.73	16.26	-	
TQK 130 3_40	400	600	1000	2000	4500	7'	6'	56	9000	8000	91	14.72	14.88	15.46	15.99	-	
TQK 130 3_50	400	600	1000	2000	4500	7'	6'	56	9000	8000	91	14.61	14.77	15.35	15.88	-	
TQK 130 3_70	400	600	1000	2000	4500	7'	6'	56	9000	8000	91	14.52	14.68	15.25	15.78	-	
TQK 130 3_80	400	600	1000	2000	4500	7'	6'	56	9000	8000	91	14.47	14.63	15.21	15.74	-	
TQK 130 3_100	400	600	1000	2000	4500	7'	6'	56	9000	8000	91	14.46	14.62	15.20	15.73	-	
TQK 130 3_140	360	550	950	2000	4500	7'	6'	56	9000	8000	91	14.46	14.62	15.20	15.73	-	
TQK 130 3_200	280	420	900	2000	4500	7'	6'	56	9000	8000	91	14.46	14.62	15.20	15.73	-	

TQK 160

95A2 ... 230A

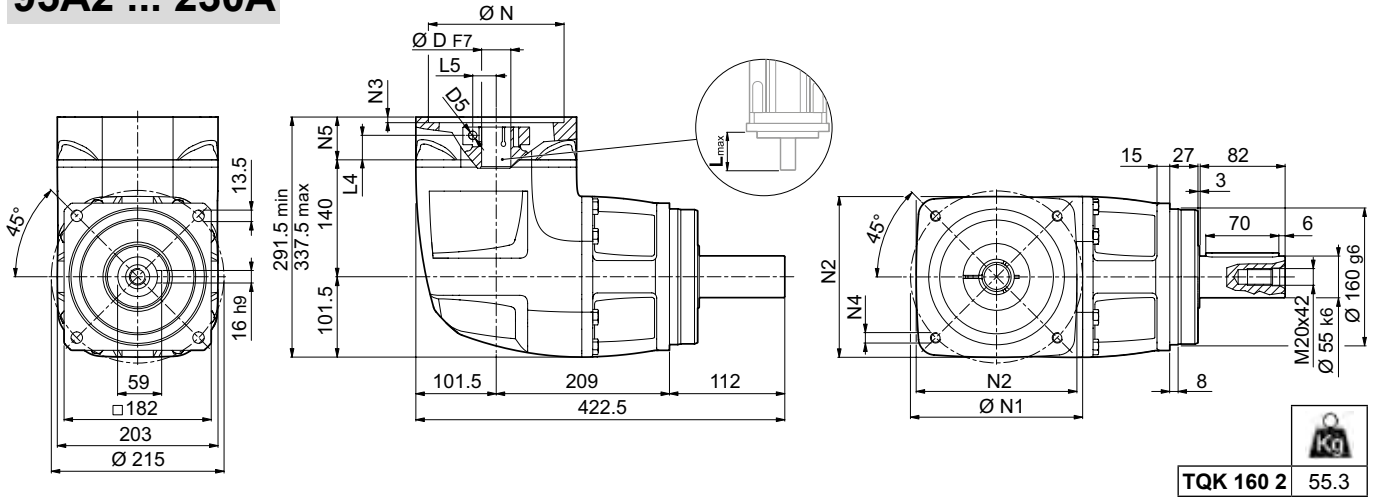

80A3 ... 200A

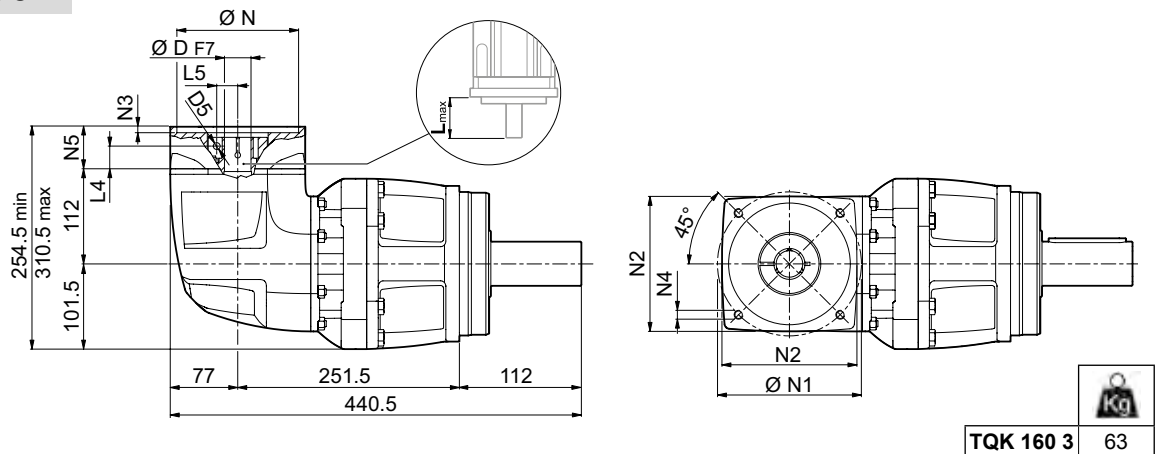

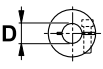
									N	N1	N2	N3	N4	N5	L _{max}
TQK 160 2															
95A2	19	24	28	-	-	-	-	95	115	158	6.5	M8x20	50	60	
110A2	19	24	-	-	-	-	-	110	130	158	6.5	M8x20	50	60	
130A1	19	24	28	32	-	-	-	130	165	158	6.5	M10x20	50	60	
180A	19	24	28	32	-	-	-	180	215	203	6.5	M14x28	50	60	
180A1	19	24	28	32	38	-	-	180	215	205	6.5	M14x28	60	80	
200A	19	24	28	32	38	42	48	200	235	220	6.5	M14x28	96	110	
230A	19	24	28	32	38	42	48	230	265	240	6.5	M14x28	96	110	
TQK 160 3															
80A3	19	-	-	-	-	-	-	80	100	130	6.5	M6x14	41	60	
95A2	19	24	28	-	-	-	-	95	115	130	6.5	M8x18	41	60	
110A2	19	24	-	-	-	-	-	110	130	130	6.5	M8x20	41	60	
110B1	19	24	28	-	-	-	-	110	145	130	6.5	M8x20	41	60	
130A1	19	24	28	32	-	-	-	130	165	154	6.5	M10x20	41	60	
180A	19	24	28	32	-	-	-	180	215	190	6.5	M14x28	41	60	
180A1	19	24	28	32	38	-	-	180	215	190	6.5	M14x28	61	80	
200A	19	24	28	32	38	42	-	200	235	210	6.5	M14x28	97	110	

Please contact us for other motor adapters and input shaft bore.

TQK 160

FM

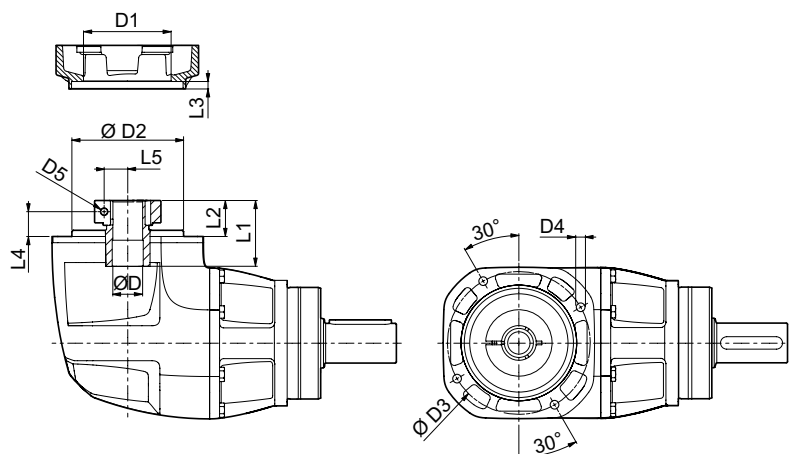

TQK

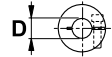
	D1	D2	D3	D4	D5	L1	L2	L3	L4	L5
TQK 160 2										
24	58	150	175	M12x20	M6	47	37	9.5	28	19
28	70	150	175	M12x20	M8	47	37	9.5	28	22.5
32	72	150	175	M12x20	M8	47	37	9.5	28	24.5
38	100	150	175	M12x20	M8	59.5	39.5	9.5	28	28
42	114	150	175	M12x20	M10	57	43	9.5	28	33
48	125	150	175	M12x20	M12	57	43	9.5	28	36.5
TQK 160 3										
19	54	120	140	M10x16	M6	50	31	7.5	23.5	16.5
24	70	120	140	M10x16	M6	51.5	32.5	7.5	23.5	19
28	70	120	140	M10x16	M8	51.5	32.5	7.5	23.5	22.5
32	72	120	140	M10x16	M8	51.5	32.5	7.5	23.5	24.5
38	100	120	140	M10x16	M8	54	35	7.5	23.5	28
42	114	120	140	M10x16	M10	51.5	38.5	7.5	23.5	33

	M_{n2}	M_{a2}	M_{p2}	n_1	n_{1max}	φ_S	φ_R	C_t	R_{2max}	A_{2max}	η	J_G [kgcm ²]				
												i	[Nm]	[Nm]	[Nm]	[min ⁻¹]
TQK 160 2_6	420	630	840	1600	4000	5'	4'	167	15000	13000	94	-	73.33	73.51	75.57	79.19
TQK 160 2_8	560	840	1120	1600	4000	5'	4'	167	15000	13000	94	-	69.49	69.66	71.73	75.34
TQK 160 2_10	700	1050	1400	1600	4000	5'	4'	167	15000	13000	94	-	67.98	68.16	70.22	73.83
TQK 160 2_14	750	1150	2000	1600	4000	5'	4'	167	15000	13000	94	-	66.68	66.85	68.92	72.53
TQK 160 2_20	550	850	1600	1600	4000	5'	4'	167	15000	13000	94	-	65.94	66.12	68.18	71.80
TQK 160 3_18	530	800	1500	1600	4000	7'	6'	167	15000	13000	91	66.84	67.17	67.34	69.41	-
TQK 160 3_24	800	1200	2000	1600	4000	7'	6'	167	15000	13000	91	66.47	66.79	66.97	69.03	-
TQK 160 3_30	800	1200	2000	1600	4000	7'	6'	167	15000	13000	91	66.30	66.63	66.80	68.87	-
TQK 160 3_40	800	1200	2000	1600	4000	7'	6'	167	15000	13000	91	65.41	65.73	65.91	67.97	-
TQK 160 3_50	800	1200	2000	1600	4000	7'	6'	167	15000	13000	91	64.99	65.32	65.49	67.56	-
TQK 160 3_70	800	1200	2000	1600	4000	7'	6'	167	15000	13000	91	64.67	65.00	65.17	67.24	-
TQK 160 3_80	800	1200	2000	1600	4000	7'	6'	167	15000	13000	91	64.51	64.84	65.01	67.08	-
TQK 160 3_100	800	1200	2000	1600	4000	7'	6'	167	15000	13000	91	64.49	64.82	65.00	67.06	-
TQK 160 3_140	750	1150	2000	1600	4000	7'	6'	167	15000	13000	91	64.48	64.81	64.99	67.05	-
TQK 160 3_200	550	850	1600	1600	4000	7'	6'	167	15000	13000	91	64.47	64.80	64.98	67.04	-

TQK

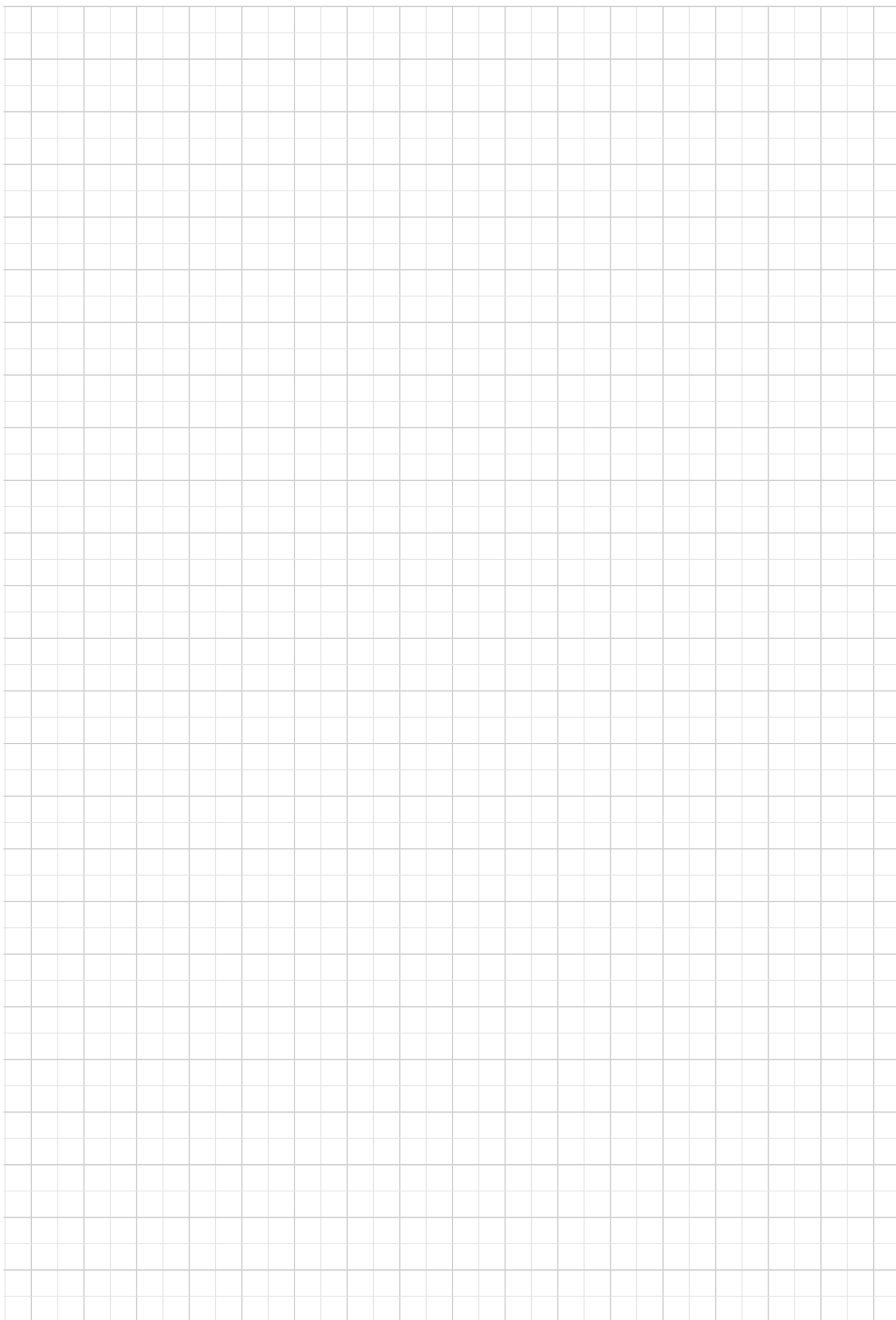

TR PLANETARY PRECISION GEARBOX

TR planetary precision gearboxes are landmark for extremely reduced backlash, optimal performance, silent operation and facilitated motor assembly along with top reliability.

Available in different configuration (with input right angle; with output right angle and hollow shaft; with solid input shaft), and servo-adapters to comply with most servomotors mechanical interface from the market.

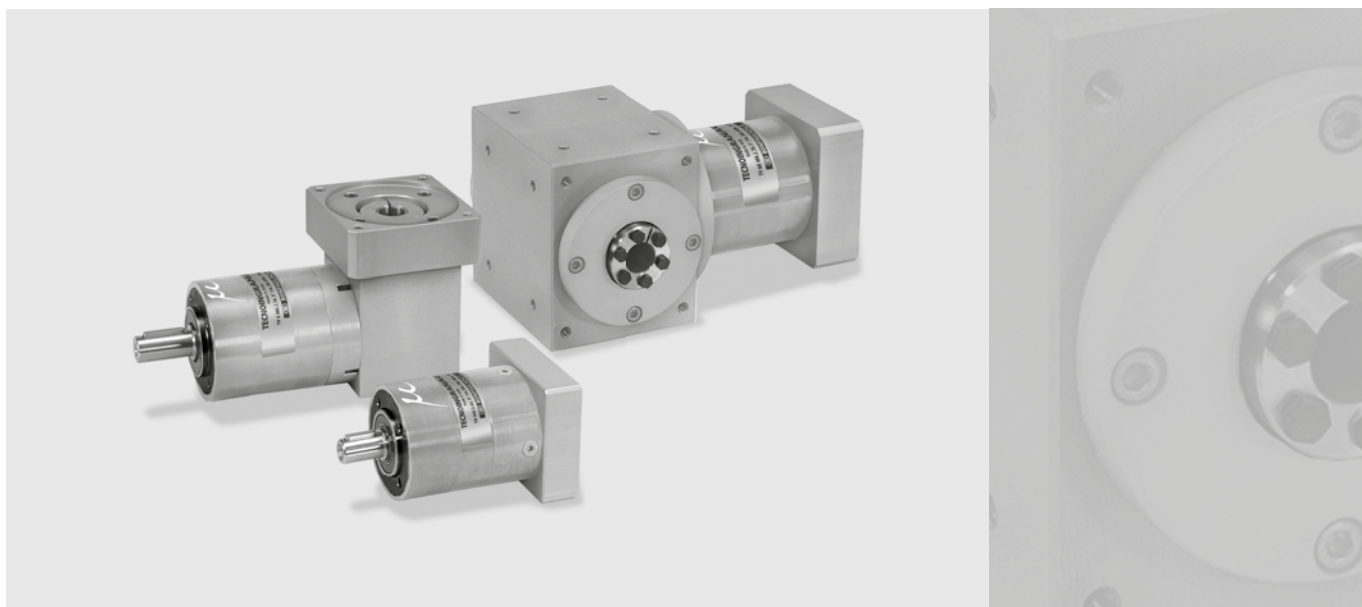

Product Line Up:

- Higher Torque Density
- Higher Acceleration and Nominal Torques
- Higher Radial and Axial Load Capacities
- Designed for Cyclic and Continuous Duty
- Higher Torsional Stiffness
- Higher Precision due to Geometrical Backlash less than 3 arcmin
- Quiet Running
- Highest Flexibility (Low / Reduced Backlash; Standard / Reinforced Bearings)
- Different Constructive Version to match with your Specific Requirement.

5 FEATURES OF TR SERIES

Planetary gear units of the TR series belong to a range of low backlash drives very broad and complete as far as transmissible torque, gear ratios and circumferential backlash.

All units are generously proportioned to run quietly and provide a long service life without maintenance requirements.

Motor mounting is an operation that can be easily conducted without the need of any particular tooling, other than that usually available in a normally equipped workshop.

- Available with either standard (STD) or reduced (LOW) backlash:
1-stage units: standard $\Psi_S \leq 5'$; reduced $\Psi_R \leq 3'$
2-stage units: standard $\Psi_S \leq 5'$; reduced $\Psi_R \leq 3'$
3-stage units (G and MB only): standard $\Psi_R \leq 5'$; reduced $\Psi_R \leq 3'$
3-stage units: standard $\Psi_S \leq 7'$; reduced $\Psi_R \leq 5'$
4-stage units (G and MB only): standard $\Psi_S \leq 7'$; reduced $\Psi_R \leq 5'$
- A high IP rating (IP65) provides inner parts with protection against the ingress of dust and liquids.
- Input section oil seals made from a Fluoroelastomer compound are supplied as standard.
- Noise pressure level $L_P \leq 70$ dB(A). Conditions: distance 1 m; measured without load an input speed of $n_1 = 3000$ min⁻¹; $i=10$.
- Bearings suitably rated for an average service life of 20,000 hours under nominal operating conditions. The following chart shows the types of bearings for the output shaft.

	TR 053	TR 060	TR 080	TR 105	TR 130	TR 160	TR 190
SB							

TR

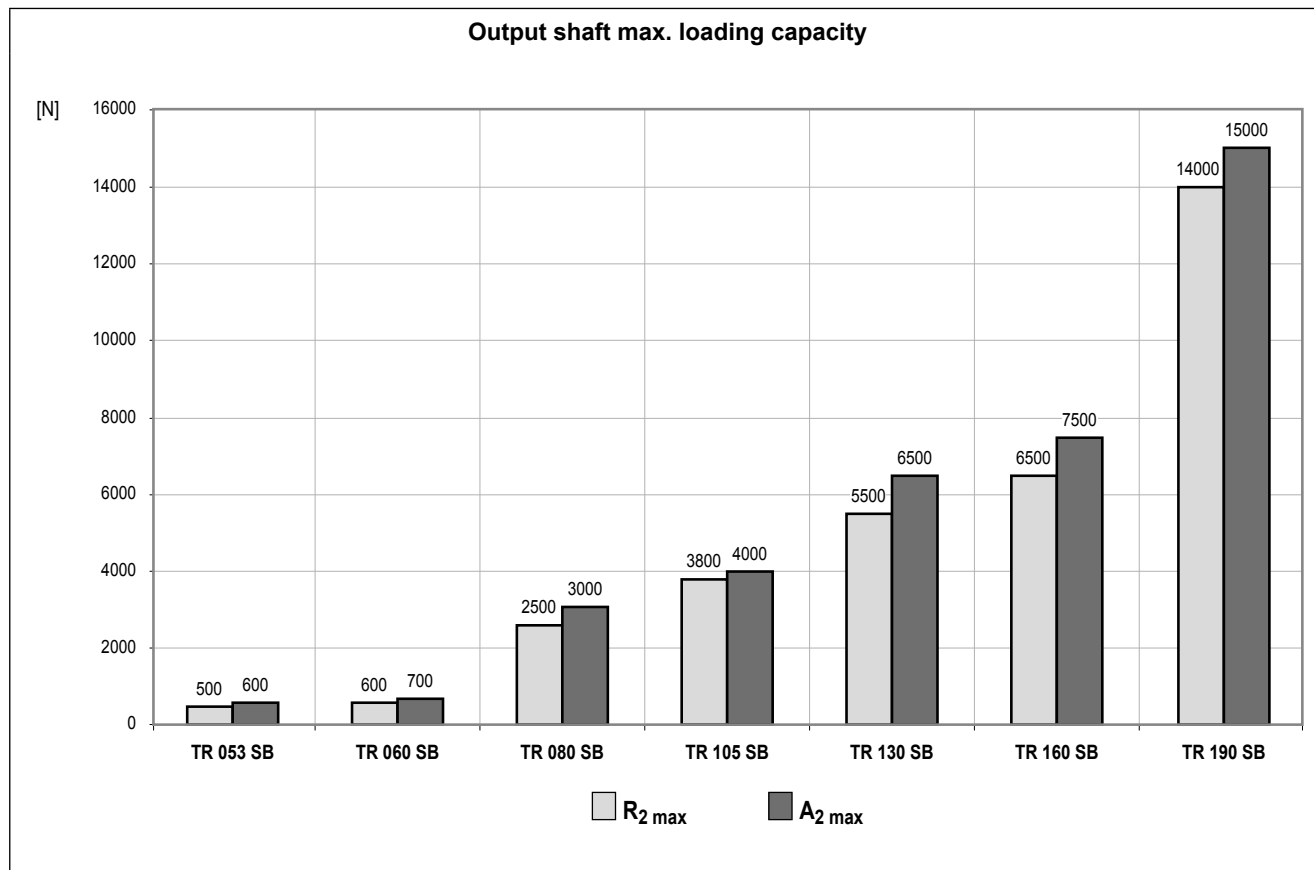

- Wide range of adapter flanges matching the most popular brands of motors.

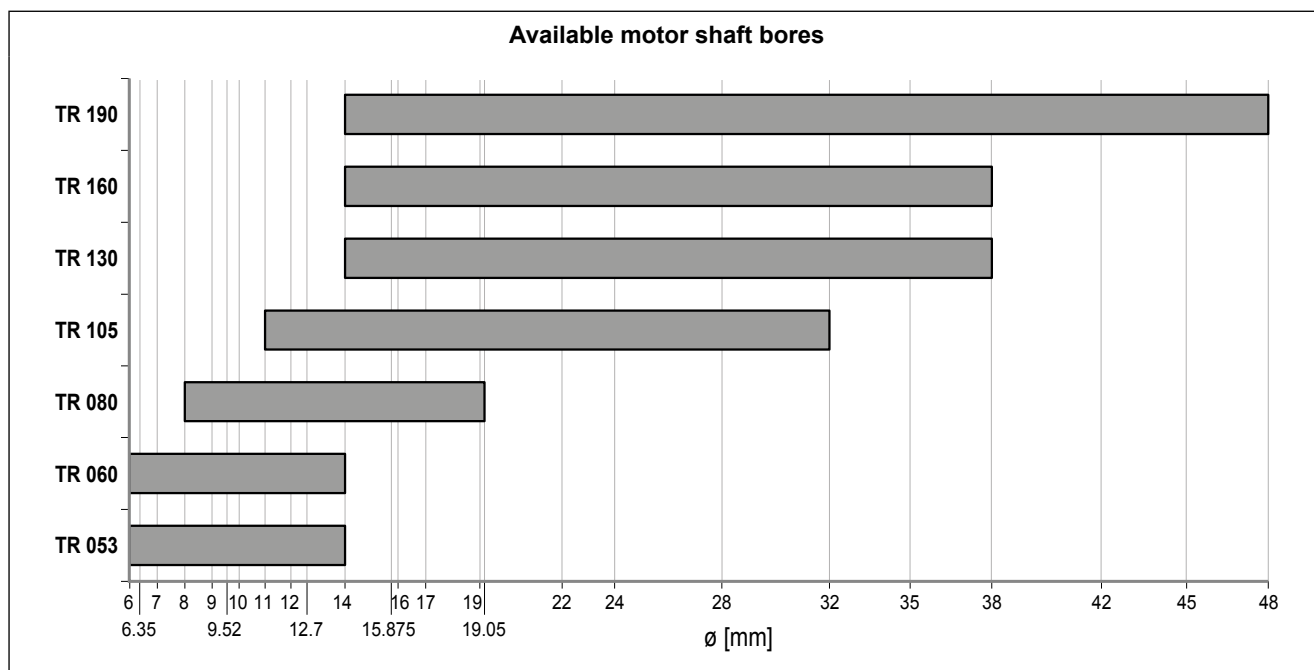

- Lubrication optimized for the type of duty specified when ordering.
In the absence of contamination the lubricant requires no periodical changes.

duty	TR 053 - TR 060	TR 080 ... TR 190	oil seals
S1 (continuous)	NLGI grease consistency 00	Synthetic oil viscosity ISO VG 220	Fluoroelastomer
S5 (intermittent)		NLGI grease consistency 00	NBR

- Ambient temperature min -20°C, max +30°C. For temperature higher than 30°C please consider derating factor f_T .
- Housing temperature must not exceed $T_{max} = 90^\circ\text{C}$.

		Distribution of nominal torque M_{n2} [Nm]																											
	[I]	3	4	5	6	7	9	10	12	15	16	20	25	28	30	35	36	40	45	48	50	60	64	70	75	80	81	84	90
TR 053		12	15	15	15	15	12	-	20	20	20	20	20	20	-	20	15	-	20	20	-	20	20	-	20	20	12	20	-
TR 060		18	25	25	25	25	18	18	30	30	30	30	30	30	18	30	25	30	-	30	30	-	30	30	30	30	-	30	18
TR 080		40	50	50	50	50	40	40	70	70	70	70	70	70	40	70	50	70	-	70	70	-	70	70	70	70	-	70	40
TR 105		100	140	140	140	140	100	100	170	170	170	170	170	170	100	170	140	170	-	170	170	-	170	170	170	170	-	170	100
TR 130		215	380	380	380	380	215	215	450	450	450	450	450	450	215	450	380	450	-	450	450	-	450	450	450	450	-	450	215
TR 160		350	500	500	500	500	350	350	700	700	700	700	700	700	350	700	500	700	-	700	700	-	700	700	700	700	-	700	350
TR 190		500	700	700	700	700	500	500	1000	1000	1000	1000	1000	1000	500	1000	700	1000	-	1000	1000	-	1000	1000	1000	1000	-	1000	500
	[II]	100	112	120	125	140	144	150	160	175	180	200	210	216	225	245	250	252	280	324	350	400	405	500	567	700	729	1000	
TR 053		20	20	-	20	20	20	-	-	20	20	-	-	20	20	20	-	20	-	20	-	-	20	-	20	-	12	-	
TR 060		18	-	30	30	30	-	30	30	30	-	30	30	30	-	-	30	-	30	-	30	30	-	30	-	30	-	18	
TR 080		40	-	70	70	70	-	70	70	70	-	70	70	70	-	-	70	-	70	-	70	70	-	70	-	70	-	40	
TR 105		100	-	170	170	170	-	170	170	170	-	170	170	170	-	-	170	-	170	-	170	170	-	170	-	170	-	100	
TR 130		215	-	450	450	450	-	450	450	450	-	450	450	450	-	-	450	-	450	-	450	450	-	450	-	450	-	215	
TR 160		700	-	350	700	700	-	700	700	700	-	700	700	-	-	700	-	700	-	700	-	700	700	-	700	-	700	-	350
TR 190		1000	-	500	1000	1000	-	1000	1000	1000	-	1000	1000	-	-	1000	-	1000	-	1000	-	1000	1000	-	1000	-	1000	-	500

TR

5.1 ORDERING CODE

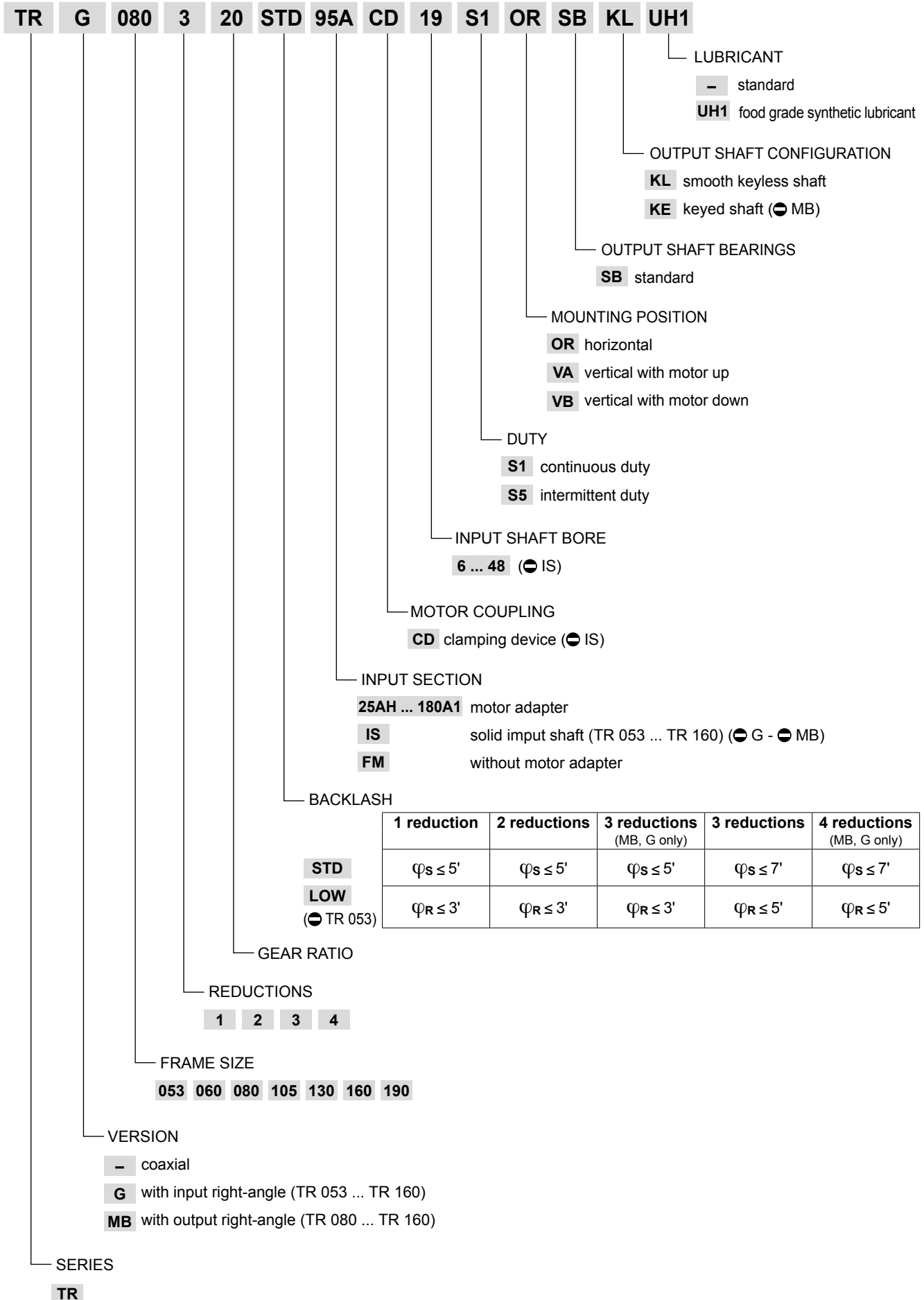

5.1.1 VERSION AND INPUT SECTION

INPUT SECTION	VERSION		
	coaxial (—)	with input right-angle (G)	with output right-angle (MB)
25AH ... 180A1			
IS		—	—
FM			

5.1.2 MOUNTING POSITIONS

	OR	VA	VB
—			
G			
MB			

TR

5.2 ADMISSIBLE RADIAL AND AXIAL FORCES FOR MB VERSION

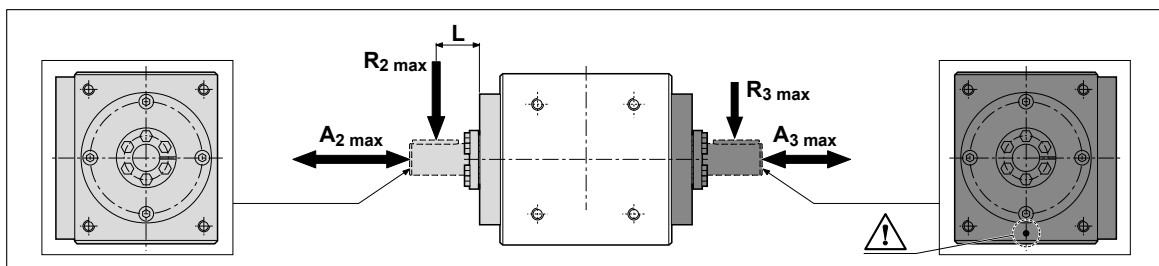

	R ₂ max [N]	A ₂ max [N]	L [mm]		R ₃ max [N]	A ₃ max [N]
TR MB 080	6000	5000	60		5500	5000
TR MB 105	9000	7500	80		7500	7500
TR MB 130	13500	11500	100		11000	11500
TR MB 160*	15000	11500	100		12500	11500

* Bearings suitably rated for an average service life of 10,000 hours under nominal operating conditions.

5.3 DIMENSIONS AND TECHNICAL SPECIFICATIONS

TR 053

IS

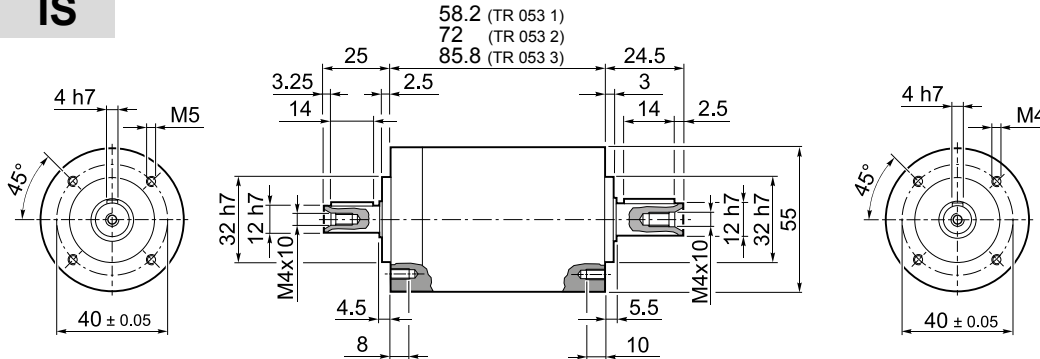

TR 053 1	0.8
TR 053 2	1.0
TR 053 3	1.3

25AH ... 80A

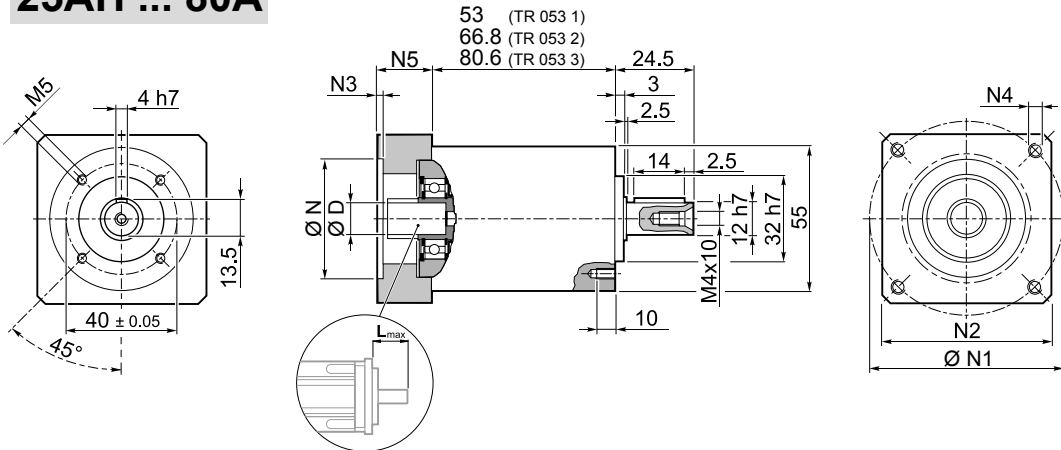

TR 053 1	0.8
TR 053 2	1.0
TR 053 3	1.3

	D											N	N1		N2	N3	N4	N5	L _{max}
		6	6.35	7	8	9	9.52	10	11	12	12.7		14	min					
25AH		6	6.35	7	8	9	9.52	-	-	-	-	25	36	48					
26AH		6	6.35	7	8	9	9.52	-	-	-	-	26	36	48					
28AH		6	6.35	7	8	9	9.52	-	-	-	-	28	36	48					
30AH		6	6.35	7	8	9	9.52	-	-	-	-	30	36	48					
32AH		6	6.35	7	8	9	9.52	-	-	-	-	32	38	48	55	3.5	4.5	25	25
34AH		6	6.35	7	8	9	9.52	-	-	-	-	34	40	48					
36AH		6	6.35	7	8	9	9.52	-	-	-	-	36	42	48					
38AH		6	6.35	7	8	9	9.52	-	-	-	-	38	44	48					
40AH		6	6.35	7	8	9	9.52	-	-	-	-	40	46	48					
38B		6	6.35	7	8	9	9.52	10	11	12	12.7	38.1	66.6	60	3	M4x10	18	25	
40B		6	6.35	7	8	9	9.52	10	11	12	12.7	40	63	60	3	M4x10	18	25	
50A		6	6.35	7	8	9	9.52	10	11	12	12.7	50	60	60	3	M4x10	18	25	
50B		6	6.35	7	8	9	9.52	10	11	12	12.7	50	65	60	3	M5x12	23	30	
50BH		6	6.35	7	8	9	9.52	10	11	12	12.7	50	65	60	4	5.5	23	30	
50C		6	6.35	7	8	9	9.52	10	11	12	12.7	50	70	60	3	M4x10	23	30	
50MH		6	6.35	7	8	9	9.52	10	11	12	12.7	50	65	55	2	5.5	16	23	
60A		6	6.35	7	8	9	9.52	10	11	12	12.7	60	75	63	3	M5x12	18	25	
60AH		6	6.35	7	8	9	9.52	10	11	12	12.7	60	75	65	3	5.5	18	25	
60A1		6	6.35	7	8	9	9.52	10	11	12	12.7	60	75	63	3	M5x12	23	30	
60AH1		6	6.35	7	8	9	9.52	10	11	12	12.7	60	75	65	3	5.5	23	30	
60B		6	6.35	7	8	9	9.52	10	11	12	12.7	60	85	75	3	M5x12	23	30	
60C		6	6.35	7	8	9	9.52	10	11	12	12.7	60	90	75	3	M5x12	23	30	
70A		6	6.35	7	8	9	9.52	10	11	12	12.7	70	85	75	3	M6x15	23	30	
70B		6	6.35	7	8	9	9.52	10	11	12	12.7	70	90	75	3	M5x12	23	30	
73A		6	6.35	7	8	9	9.52	10	11	12	12.7	73	98.4	85	3	M5x12	25	32	
80A		6	6.35	7	8	9	9.52	10	11	12	12.7	80	100	85	3	M6x15	23	30	

Please contact us for other motor adapters and input shaft bore.

TR 053

FM

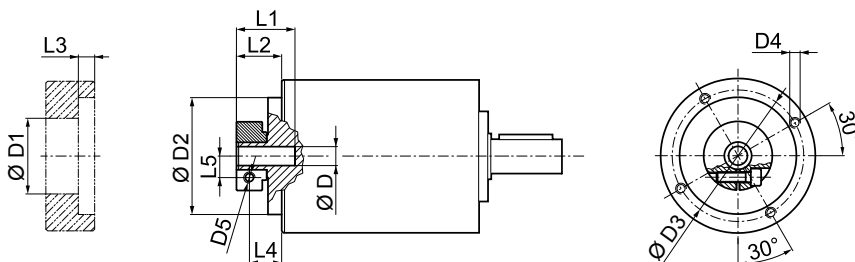

				D1	D2	D3	D4	D5	L1	L2	L3	L4	L5
6	6.35	7		32.5	50	42.5	M4x8	M4	20.2	13.2	3	8.7	8
8	9	9.52	10	32.5	50	42.5	M4x8	M4	20.2	13.2	3	7.8	9
11	12	12.7		35.5	50	42.5	M4x8	M4	20.5	13.5	3	8.5	11
14				35.5	50	42.5	M4x8	M4	24	17	3	10.2	11.5

	i	M _{n 2}	M _{a 2}	M _{p 2}	n ₁	n _{1 max}	ψ _S	C _t	R _{1 max}	R _{2 max}	A _{2 max}	η	J _G [kgcm ²]	
		[Nm]	[Nm]	[Nm]	[min ⁻¹]	[min ⁻¹]	[arcmin]	$\frac{Nm}{arcmin}$	[N]	[N]	[N]	%		6 ... 9.52
TR 053 1_3		12	22	40	3300	4000	5'	1.0	200	500	600	97	0.06	0.08
TR 053 1_4		15	28	45	3500	5000	5'	1.0	200	500	600	97	0.05	0.06
TR 053 1_5		15	28	45	3500	5000	5'	1.0	200	500	600	97	0.04	0.06
TR 053 1_6		15	28	45	3500	5000	5'	1.0	200	500	600	97	0.03	0.05
TR 053 1_7		15	28	45	4000	6000	5'	1.0	200	500	600	97	0.03	0.05
TR 053 1_9		12	22	40	4000	6000	5'	1.0	200	500	600	97	0.03	0.05
TR 053 2_12		20	30	60	3300	4000	5'	0.9	200	500	600	94	0.06	0.08
TR 053 2_15		20	30	60	3300	4000	5'	0.9	200	500	600	94	0.06	0.08
TR 053 2_16		20	30	60	3500	5000	5'	0.9	200	500	600	94	0.05	0.06
TR 053 2_20		20	30	60	3500	5000	5'	0.9	200	500	600	94	0.04	0.06
TR 053 2_25		20	30	60	3500	5000	5'	0.9	200	500	600	94	0.04	0.06
TR 053 2_28		20	30	60	4000	6000	5'	0.9	200	500	600	94	0.03	0.05
TR 053 2_35		20	30	60	4000	6000	5'	0.9	200	500	600	94	0.03	0.05
TR 053 2_36		15	28	45	4000	6000	5'	0.9	200	500	600	94	0.03	0.05
TR 053 2_45		20	30	60	4000	6000	5'	0.9	200	500	600	94	0.03	0.05
TR 053 2_81		12	22	40	3500	6000	5'	0.9	200	500	600	94	0.03	0.05
TR 053 3_48		20	30	60	4000	5000	7'	0.7	200	500	600	91	0.05	0.07
TR 053 3_60		20	30	60	3500	5000	7'	0.7	200	500	600	91	0.05	0.07
TR 053 3_64		20	30	60	3500	5000	7'	0.7	200	500	600	91	0.05	0.06
TR 053 3_75		20	30	60	3500	5000	7'	0.7	200	500	600	91	0.04	0.06
TR 053 3_80		20	30	60	3500	5000	7'	0.7	200	500	600	91	0.05	0.06
TR 053 3_84		20	30	60	4000	6000	7'	0.7	200	500	600	91	0.03	0.05
TR 053 3_100		20	30	60	3500	5000	7'	0.7	200	500	600	91	0.04	0.06
TR 053 3_112		20	30	60	4000	6000	7'	0.7	200	500	600	91	0.03	0.05
TR 053 3_125		20	30	60	3500	5000	7'	0.7	200	500	600	91	0.04	0.06
TR 053 3_140		20	30	60	4000	6000	7'	0.7	200	500	600	91	0.03	0.05
TR 053 3_144		20	30	60	4000	6000	7'	0.7	200	500	600	91	0.03	0.05
TR 053 3_175		20	30	60	4000	6000	7'	0.7	200	500	600	91	0.03	0.05
TR 053 3_180		20	30	60	4000	6000	7'	0.7	200	500	600	91	0.03	0.05
TR 053 3_216		20	30	60	3500	5000	7'	0.7	200	500	600	91	0.03	0.05
TR 053 3_225		20	30	60	4000	6000	7'	0.7	200	500	600	91	0.03	0.05
TR 053 3_245		20	30	60	4000	6000	7'	0.7	200	500	600	91	0.03	0.05
TR 053 3_252		20	30	60	4000	6000	7'	0.7	200	500	600	91	0.05	0.06
TR 053 3_324		20	30	60	4000	6000	7'	0.7	200	500	600	91	0.03	0.05
TR 053 3_405		20	30	60	4000	6000	7'	0.7	200	500	600	91	0.03	0.05
TR 053 3_567		20	30	60	4000	6000	7'	0.7	200	500	600	91	0.03	0.05
TR 053 3_729		12	22	40	4000	6000	7'	0.7	200	500	600	91	0.03	0.05

TR

TR G 053

25AH ... 80A

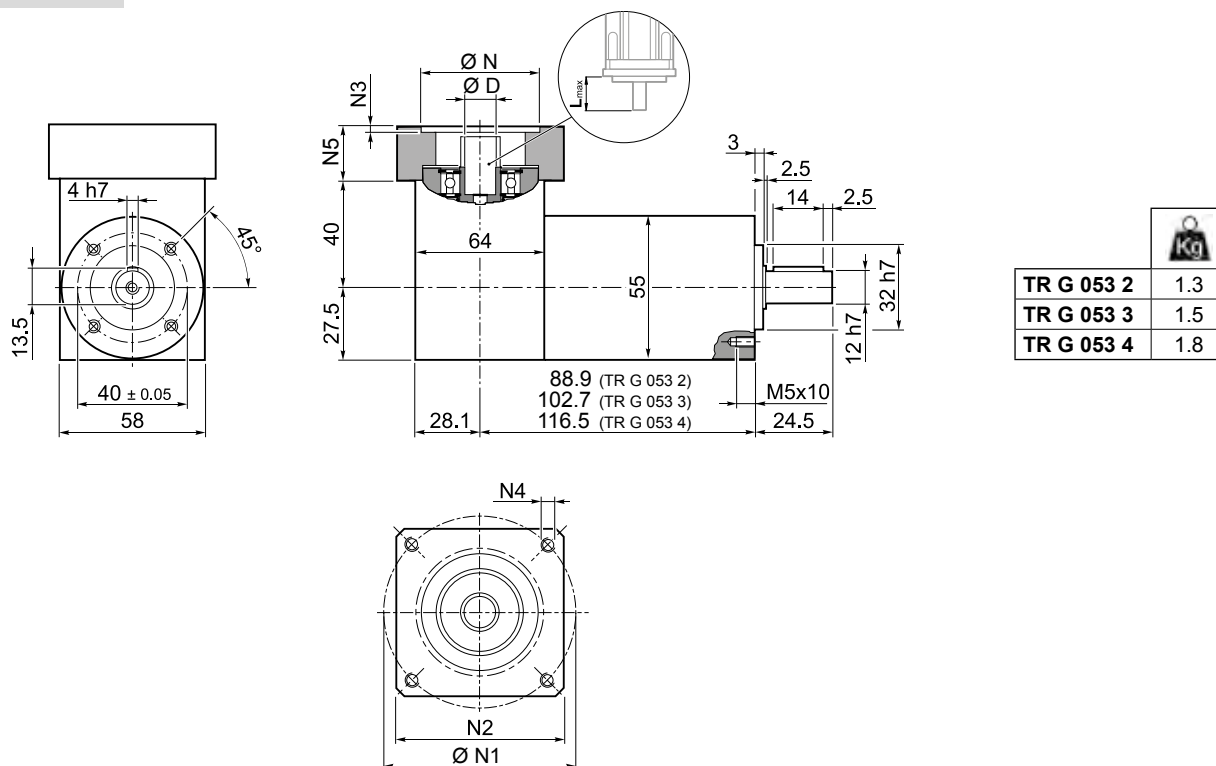

TR

	D											N	N1		N2	N3	N4	N5	Lmax
	6	6.35	7	8	9	9.52	-	-	-	-	-		min	max					
25AH	6	6.35	7	8	9	9.52	-	-	-	-	-	25	36	48					
26AH	6	6.35	7	8	9	9.52	-	-	-	-	-	26	36	48					
28AH	6	6.35	7	8	9	9.52	-	-	-	-	-	28	36	48					
30AH	6	6.35	7	8	9	9.52	-	-	-	-	-	30	36	48					
32AH	6	6.35	7	8	9	9.52	-	-	-	-	-	32	38	48	55	3.5	4.5	25	25
34AH	6	6.35	7	8	9	9.52	-	-	-	-	-	34	40	48					
36AH	6	6.35	7	8	9	9.52	-	-	-	-	-	36	42	48					
38AH	6	6.35	7	8	9	9.52	-	-	-	-	-	38	44	48					
40AH	6	6.35	7	8	9	9.52	-	-	-	-	-	40	46	48					
38B	6	6.35	7	8	9	9.52	10	11	12	12.7	-	38.1	66.6	60	3	M4x10	18	25	
40B	6	6.35	7	8	9	9.52	10	11	12	12.7	-	40	63	60	3	M4x10	18	25	
50A	6	6.35	7	8	9	9.52	10	11	12	12.7	-	50	60	60	3	M4x10	18	25	
50B	6	6.35	7	8	9	9.52	10	11	12	12.7	14	50	65	60	3	M5x12	23	30	
50BH	6	6.35	7	8	9	9.52	10	11	12	12.7	14	50	65	60	4	5.5	23	30	
50C	6	6.35	7	8	9	9.52	10	11	12	12.7	14	50	70	60	3	M4x10	23	30	
50MH	6	6.35	7	8	9	9.52	10	11	12	12.7	-	50	65	55	2	5.5	16	23	
60A	6	6.35	7	8	9	9.52	10	11	12	12.7	-	60	75	63	3	M5x12	18	25	
60A1	6	6.35	7	8	9	9.52	10	11	12	12.7	14	60	75	63	3	M5x12	23	30	
60B	6	6.35	7	8	9	9.52	10	11	12	12.7	14	60	85	75	3	M5x12	23	30	
60C	6	6.35	7	8	9	9.52	10	11	12	12.7	14	60	90	75	3	M5x12	23	30	
70A	6	6.35	7	8	9	9.52	10	11	12	12.7	14	70	85	75	3	M6x15	23	30	
70B	6	6.35	7	8	9	9.52	10	11	12	12.7	14	70	90	75	3	M5x12	23	30	
73A	6	6.35	7	8	9	9.52	10	11	12	12.7	14	73	98.4	85	3	M5x12	25	32	
80A	6	6.35	7	8	9	9.52	10	11	12	12.7	14	80	100	85	3	M6x15	23	30	

Please contact us for other motor adapters and input shaft bore.

TR G 053

FM

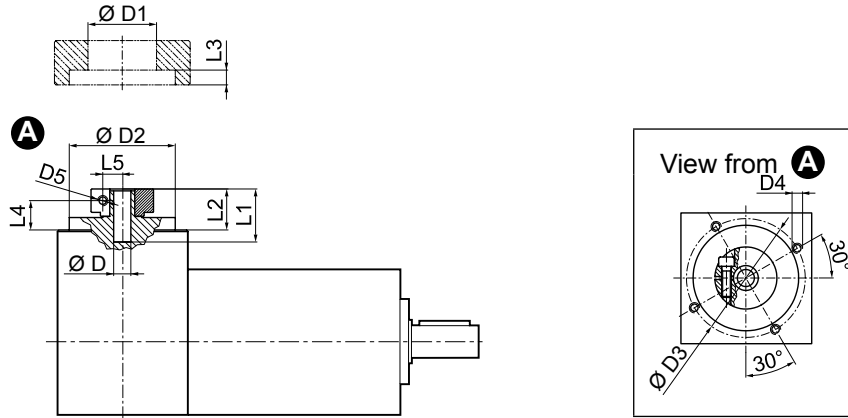

D		D1	D2	D3	D4	D5	L1	L2	L3	L4	L5
6	6.35 7	32.5	50	42.5	M4x8	M4	20.2	13.2	3	8.7	8
8	9 9.52 10	32.5	50	42.5	M4x8	M4	20.2	13.2	3	7.8	9
11	12 12.7	35.5	50	42.5	M4x8	M4	20.5	13.5	3	8.5	11
14		35.5	50	42.5	M4x8	M4	24	17	3	10.2	11.5

i	M _{n 2}	M _{a 2}	M _{p 2}	n ₁	n _{1 max}	φ _S	C _t	R _{2 max}	A _{2 max}	%	J _G [kgcm ²]	
	[Nm]	[Nm]	[Nm]	[min ⁻¹]	[min ⁻¹]	[arcmin]	$\frac{Nm}{arcmin}$	[N]	[N]		6 ... 9.52	10 ... 14
TR G 053 2_3	12	22	40	3300	4000	5'	1.0	500	600	94	0.18	0.20
TR G 053 2_4	15	28	45	3500	5000	5'	1.0	500	600	94	0.18	0.19
TR G 053 2_5	15	28	45	3500	5000	5'	1.0	500	600	94	0.17	0.19
TR G 053 2_6	15	28	45	3500	5000	5'	1.0	500	600	94	0.17	0.18
TR G 053 2_7	15	28	45	4000	6000	5'	1.0	500	600	94	0.17	0.19
TR G 053 2_9	12	22	40	4000	6000	5'	1.0	500	600	94	0.17	0.18
TR G 053 3_12	20	30	60	3300	4000	5'	0.9	500	600	91	0.18	0.20
TR G 053 3_15	20	30	60	3300	4000	5'	0.9	500	600	91	0.18	0.20
TR G 053 3_16	20	30	60	3500	5000	5'	0.9	500	600	91	0.17	0.19
TR G 053 3_20	20	30	60	3500	5000	5'	0.9	500	600	91	0.17	0.19
TR G 053 3_25	20	30	60	3500	5000	5'	0.9	500	600	91	0.17	0.19
TR G 053 3_28	20	30	60	4000	6000	5'	0.9	500	600	91	0.17	0.19
TR G 053 3_35	20	30	60	4000	6000	5'	0.9	500	600	91	0.17	0.19
TR G 053 3_36	15	28	45	4000	6000	5'	0.9	500	600	91	0.17	0.18
TR G 053 3_45	20	30	60	4000	6000	5'	0.9	500	600	91	0.17	0.19
TR G 053 3_81	12	22	40	3500	6000	5'	0.9	500	600	91	0.17	0.18
TR G 053 4_48	20	30	60	4000	5000	7'	0.7	500	600	89	0.18	0.19
TR G 053 4_60	20	30	60	3500	5000	7'	0.7	500	600	89	0.18	0.19
TR G 053 4_64	20	30	60	3500	5000	7'	0.7	500	600	89	0.17	0.19
TR G 053 4_75	20	30	60	3500	5000	7'	0.7	500	600	89	0.17	0.19
TR G 053 4_80	20	30	60	3500	5000	7'	0.7	500	600	89	0.17	0.19
TR G 053 4_84	20	30	60	4000	6000	7'	0.7	500	600	89	0.17	0.19
TR G 053 4_100	20	30	60	3500	5000	7'	0.7	500	600	89	0.17	0.19
TR G 053 4_112	20	30	60	4000	6000	7'	0.7	500	600	89	0.17	0.19
TR G 053 4_125	20	30	60	3500	5000	7'	0.7	500	600	89	0.17	0.19
TR G 053 4_140	20	30	60	4000	6000	7'	0.7	500	600	89	0.17	0.19
TR G 053 4_144	20	30	60	4000	6000	7'	0.7	500	600	89	0.17	0.18
TR G 053 4_175	20	30	60	4000	6000	7'	0.7	500	600	89	0.17	0.19
TR G 053 4_180	20	30	60	4000	6000	7'	0.7	500	600	89	0.17	0.18
TR G 053 4_216	20	30	60	3500	5000	7'	0.7	500	600	89	0.17	0.18
TR G 053 4_225	20	30	60	4000	6000	7'	0.7	500	600	89	0.17	0.18
TR G 053 4_245	20	30	60	4000	6000	7'	0.7	500	600	89	0.17	0.19
TR G 053 4_252	20	30	60	4000	6000	7'	0.7	500	600	89	0.18	0.20
TR G 053 4_324	20	30	60	4000	6000	7'	0.7	500	600	89	0.17	0.18
TR G 053 4_405	20	30	60	4000	6000	7'	0.7	500	600	89	0.17	0.18
TR G 053 4_567	20	30	60	4000	6000	7'	0.7	500	600	89	0.17	0.18
TR G 053 4_729	12	22	40	4000	6000	7'	0.7	500	600	89	0.17	0.18

S-M-BOR-NL-CAFS-001-V01

TR

TR 060

IS

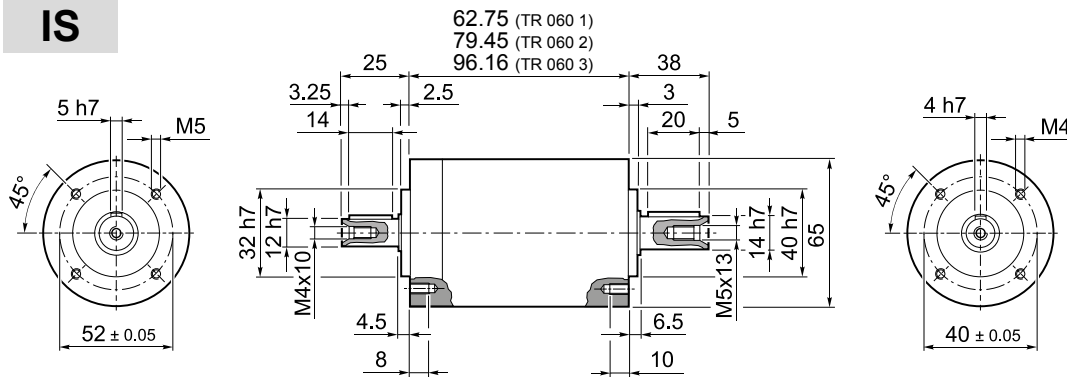

TR 060 1	1.2
TR 060 2	1.7
TR 060 3	2.0

25AH ... 80A

TR

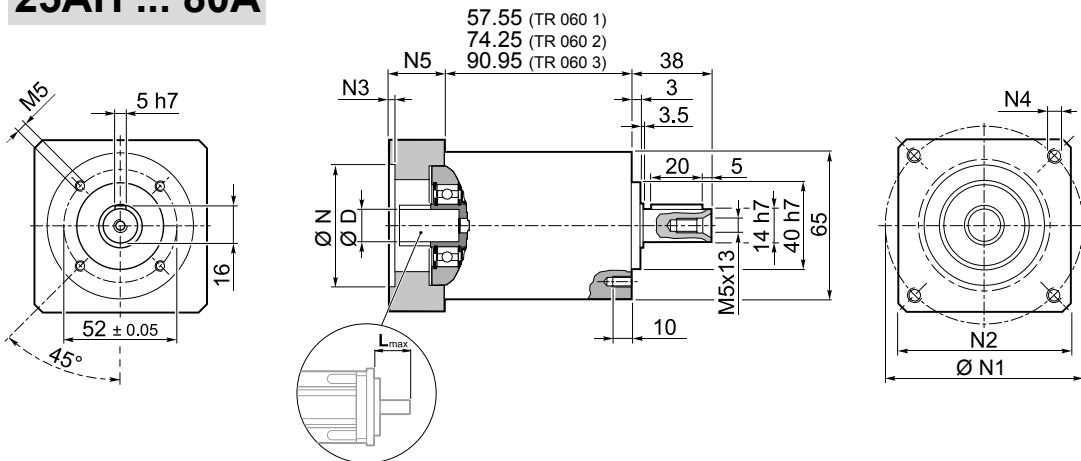

TR 060 1	1.2
TR 060 2	1.7
TR 060 3	2.0

												N	N1		N2	N3	N4	N5	L _{max}
	6	6.35	7	8	9	9.52	-	-	-	-	-		min	max					
25AH	6	6.35	7	8	9	9.52	-	-	-	-	-	25	39	56					
26AH	6	6.35	7	8	9	9.52	-	-	-	-	-	26	39	56					
28AH	6	6.35	7	8	9	9.52	-	-	-	-	-	28	39	56					
30AH	6	6.35	7	8	9	9.52	-	-	-	-	-	30	39	56					
32AH	6	6.35	7	8	9	9.52	-	-	-	-	-	32	39	56	65	3.5	4.5	25	25
34AH	6	6.35	7	8	9	9.52	-	-	-	-	-	34	40	56					
36AH	6	6.35	7	8	9	9.52	-	-	-	-	-	36	42	56					
39AH	6	6.35	7	8	9	9.52	-	-	-	-	-	39	45	56					
40AH	6	6.35	7	8	9	9.52	-	-	-	-	-	40	46	56					
38B	6	6.35	7	8	9	9.52	10	11	12	12.7	-	38.1	66.6	60	3	M4x10	18	25	
40B	6	6.35	7	8	9	9.52	10	11	12	12.7	-	40	63	60	3	M4x10	18	25	
50A	6	6.35	7	8	9	9.52	10	11	12	12.7	-	50	60	60	3	M4x10	18	25	
50B	6	6.35	7	8	9	9.52	10	11	12	12.7	14	50	65	60	3	M5x12	23	30	
50BH	6	6.35	7	8	9	9.52	10	11	12	12.7	14	50	65	65	3	5.5	25	32	
50C	6	6.35	7	8	9	9.52	10	11	12	12.7	14	50	70	60	3	M4x10	23	30	
55MH	6	6.35	7	8	9	9.52	10	11	12	12.7	-	55	80	65	2	5.5	16	23	
60A	6	6.35	7	8	9	9.52	10	11	12	12.7	-	60	75	63	3	M5x12	18	25	
60AH	6	6.35	7	8	9	9.52	10	11	12	12.7	-	60	75	65	3	5.5	18	25	
60A1	6	6.35	7	8	9	9.52	10	11	12	12.7	14	60	75	63	3	M5x12	23	30	
60AH1	6	6.35	7	8	9	9.52	10	11	12	12.7	14	60	75	65	3	5.5	23	30	
60B	6	6.35	7	8	9	9.52	10	11	12	12.7	14	60	85	75	3	M5x12	23	30	
60C	6	6.35	7	8	9	9.52	10	11	12	12.7	14	60	90	75	3	M5x12	23	30	
70A	6	6.35	7	8	9	9.52	10	11	12	12.7	14	70	85	75	3	M6x15	23	30	
70B	6	6.35	7	8	9	9.52	10	11	12	12.7	14	70	90	75	3	M5x12	23	30	
73A	6	6.35	7	8	9	9.52	10	11	12	12.7	14	73	98.4	85	3	M5x12	25	32	
80A	6	6.35	7	8	9	9.52	10	11	12	12.7	14	80	100	85	3	M6x15	23	30	

Please contact us for other motor adapters and input shaft bore.

TR 060

FM

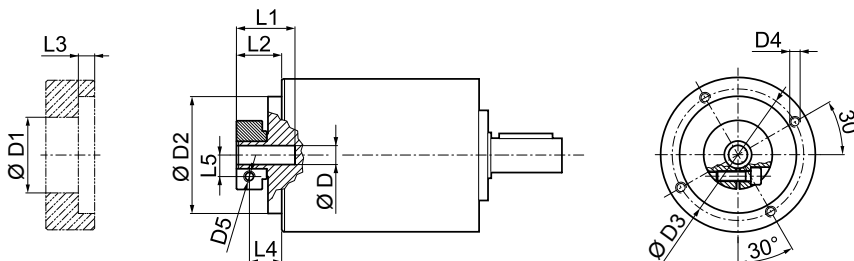

D				D1	D2	D3	D4	D5	L1	L2	L3	L4	L5
6	6.35	7		32.5	50	42.5	M4x8	M4	20.2	13.2	3	8.7	8
8	9	9.52	10	32.5	50	42.5	M4x8	M4	20.2	13.2	3	7.8	9
11	12	12.7		35.5	50	42.5	M4x8	M4	20.5	13.5	3	8.5	11
14				35.5	50	42.5	M4x8	M4	24	17	3	10.2	11.5

i	M _{n2} [Nm]	M _{a2} [Nm]	M _{p2} [Nm]	n ₁ [min ⁻¹]	n _{1 max} [min ⁻¹]	φ _S [arcmin]	φ _R [arcmin]	C _t [Nm/arcmin]	R _{1 max} [N]	R _{2 max} [N]	A _{2 max} [N]	η %	J _G [kgcm ²]	
													D	D
TR 060 1_3	18	35	70	3300	4000	5'	3'	3.0	200	600	700	97	0.10	0.11
TR 060 1_4	25	40	90	3500	5000	5'	3'	3.0	200	600	700	97	0.06	0.08
TR 060 1_5	25	40	90	3500	5000	5'	3'	3.0	200	600	700	97	0.05	0.07
TR 060 1_6	25	40	90	3500	5000	5'	3'	3.0	200	600	700	97	0.04	0.06
TR 060 1_7	25	40	90	4000	6000	5'	3'	3.0	200	600	700	97	0.04	0.06
TR 060 1_10	18	35	70	4000	6000	5'	3'	3.0	200	600	700	97	0.03	0.05
TR 060 2_9	18	35	70	3300	4000	5'	3'	2.5	200	600	700	94	0.10	0.12
TR 060 2_12	30	45	100	3300	4000	5'	3'	2.5	200	600	700	94	0.10	0.11
TR 060 2_15	30	45	100	3300	4000	5'	3'	2.5	200	600	700	94	0.09	0.11
TR 060 2_16	30	45	100	3500	5000	5'	3'	2.5	200	600	700	94	0.06	0.08
TR 060 2_20	30	45	100	3500	5000	5'	3'	2.5	200	600	700	94	0.05	0.07
TR 060 2_25	30	45	100	3500	5000	5'	3'	2.5	200	600	700	94	0.05	0.06
TR 060 2_28	30	45	100	4000	6000	5'	3'	2.5	200	600	700	94	0.04	0.06
TR 060 2_30	18	35	70	4000	6000	5'	3'	2.5	200	600	700	94	0.03	0.05
TR 060 2_35	30	45	100	4000	6000	5'	3'	2.5	200	600	700	94	0.04	0.06
TR 060 2_36	25	40	90	3500	5000	5'	3'	2.5	200	600	700	94	0.04	0.06
TR 060 2_40	30	45	100	4000	6000	5'	3'	2.5	200	600	700	94	0.03	0.05
TR 060 2_50	30	45	100	4000	6000	5'	3'	2.5	200	600	700	94	0.03	0.05
TR 060 2_70	30	45	100	4000	6000	5'	3'	2.5	200	600	700	94	0.03	0.05
TR 060 2_100	18	35	70	4000	6000	5'	3'	2.5	200	600	700	94	0.03	0.05
TR 060 3_48	30	45	100	3500	5000	7'	5'	2.0	200	600	700	91	0.06	0.08
TR 060 3_64	30	45	100	3500	5000	7'	5'	2.0	200	600	700	91	0.06	0.08
TR 060 3_75	30	45	100	3500	5000	7'	5'	2.0	200	600	700	91	0.05	0.07
TR 060 3_80	30	45	100	3500	5000	7'	5'	2.0	200	600	700	91	0.06	0.08
TR 060 3_84	30	45	100	4000	6000	7'	5'	2.0	200	600	700	91	0.04	0.06
TR 060 3_90	18	35	70	4000	6000	7'	5'	2.0	200	600	700	91	0.03	0.05
TR 060 3_120	30	45	100	4000	6000	7'	5'	2.0	200	600	700	91	0.03	0.05
TR 060 3_125	30	45	100	3500	5000	7'	5'	2.0	200	600	700	91	0.05	0.07
TR 060 3_140	30	45	100	4000	6000	7'	5'	2.0	200	600	700	91	0.04	0.06
TR 060 3_150	30	45	100	4000	6000	7'	5'	2.0	200	600	700	91	0.03	0.05
TR 060 3_160	30	45	100	4000	6000	7'	5'	2.0	200	600	700	91	0.03	0.05
TR 060 3_175	30	45	100	4000	6000	7'	5'	2.0	200	600	700	91	0.04	0.06
TR 060 3_200	30	45	100	4000	6000	7'	5'	2.0	200	600	700	91	0.03	0.05
TR 060 3_210	30	45	100	4000	6000	7'	5'	2.0	200	600	700	91	0.03	0.05
TR 060 3_216	30	45	100	3500	5000	7'	5'	2.0	200	600	700	91	0.04	0.06
TR 060 3_250	30	45	100	4000	6000	7'	5'	2.0	200	600	700	91	0.03	0.05
TR 060 3_280	30	45	100	4000	6000	7'	5'	2.0	200	600	700	91	0.03	0.05
TR 060 3_350	30	45	100	4000	6000	7'	5'	2.0	200	600	700	91	0.03	0.05
TR 060 3_400	30	45	100	4000	6000	7'	5'	2.0	200	600	700	91	0.03	0.05
TR 060 3_500	30	45	100	4000	6000	7'	5'	2.0	200	600	700	91	0.03	0.05
TR 060 3_700	30	45	100	4000	6000	7'	5'	2.0	200	600	700	91	0.03	0.05
TR 060 3_1000	18	35	70	4000	6000	7'	5'	2.0	200	600	700	91	0.03	0.05

TR

TR G 060

25AH ... 80A

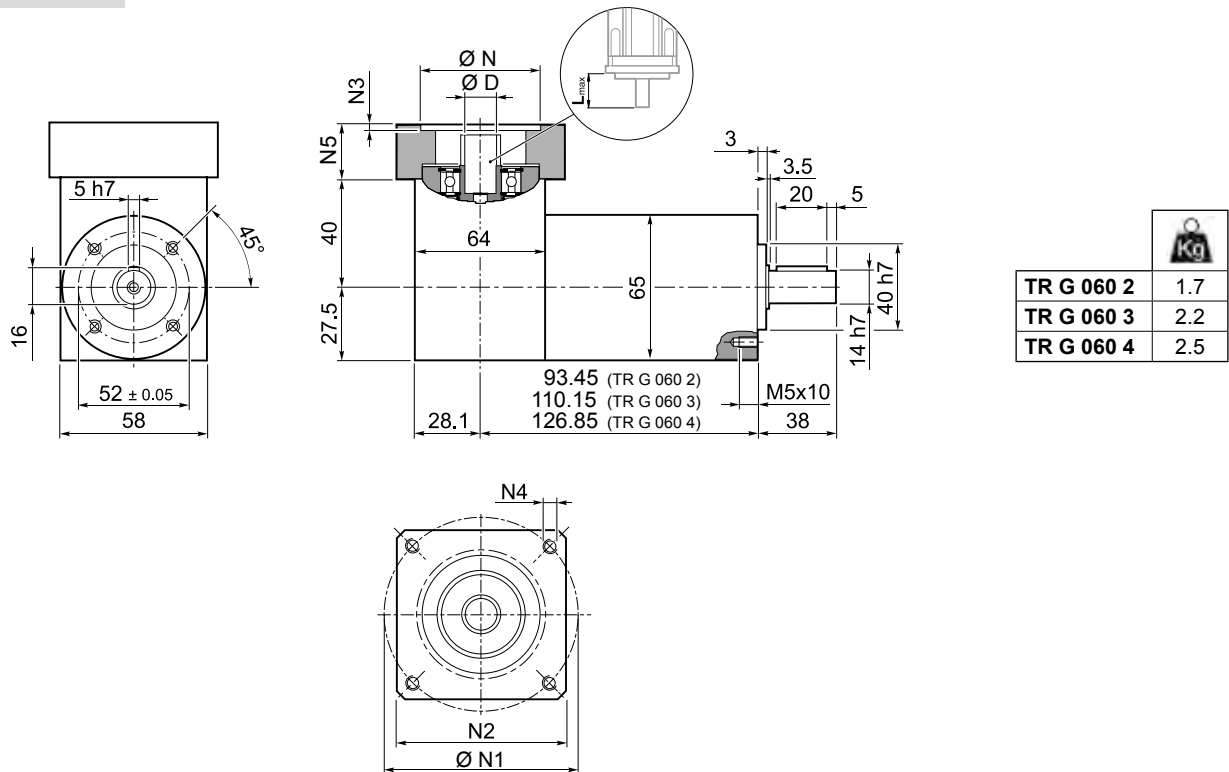

TR

			N	N1		N2	N3	N4	N5	L _{max}								
				min	max													
25AH	6	6.35	7	8	9	9.52	-	-	-	-	25	39	56					
26AH	6	6.35	7	8	9	9.52	-	-	-	-	26	39	56					
28AH	6	6.35	7	8	9	9.52	-	-	-	-	28	39	56					
30AH	6	6.35	7	8	9	9.52	-	-	-	-	30	39	56					
32AH	6	6.35	7	8	9	9.52	-	-	-	-	32	39	56	65	3.5	4.5	25	25
34AH	6	6.35	7	8	9	9.52	-	-	-	-	34	40	56					
36AH	6	6.35	7	8	9	9.52	-	-	-	-	36	42	56					
39AH	6	6.35	7	8	9	9.52	-	-	-	-	39	45	56					
40AH	6	6.35	7	8	9	9.52	-	-	-	-	40	46	56					
38B	6	6.35	7	8	9	9.52	10	11	12	12.7	-	38.1	66.6	60	3	M4x10	18	25
40B	6	6.35	7	8	9	9.52	10	11	12	12.7	-	40	63	60	3	M4x10	18	25
50A	6	6.35	7	8	9	9.52	10	11	12	12.7	-	50	60	60	3	M4x10	18	25
50B	6	6.35	7	8	9	9.52	10	11	12	12.7	14	50	65	60	3	M5x12	23	30
50BH	6	6.35	7	8	9	9.52	10	11	12	12.7	14	50	65	65	3	5.5	25	32
50C	6	6.35	7	8	9	9.52	10	11	12	12.7	14	50	70	60	3	M4x10	23	30
55MH	6	6.35	7	8	9	9.52	10	11	12	12.7	-	55	80	65	2	5.5	16	23
60A	6	6.35	7	8	9	9.52	10	11	12	12.7	-	60	75	63	3	M5x12	18	25
60A1	6	6.35	7	8	9	9.52	10	11	12	12.7	14	60	75	63	3	M5x12	23	30
60B	6	6.35	7	8	9	9.52	10	11	12	12.7	14	60	85	75	3	M5x12	23	30
60C	6	6.35	7	8	9	9.52	10	11	12	12.7	14	60	90	75	3	M5x12	23	30
70A	6	6.35	7	8	9	9.52	10	11	12	12.7	14	70	85	75	3	M6x15	23	30
70B	6	6.35	7	8	9	9.52	10	11	12	12.7	14	70	90	75	3	M5x12	23	30
73A	6	6.35	7	8	9	9.52	10	11	12	12.7	14	73	98.4	85	3	M5x12	25	32
80A	6	6.35	7	8	9	9.52	10	11	12	12.7	14	80	100	85	3	M6x15	23	30

Please contact us for other motor adapters and input shaft bore.

TR G 060

FM

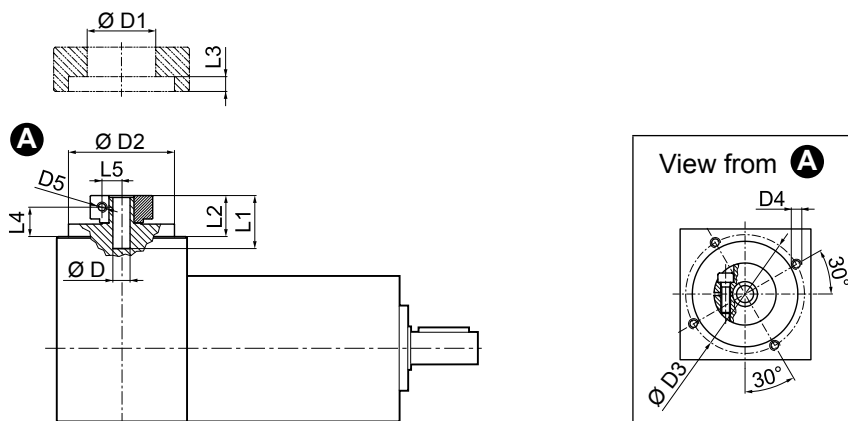

				D1	D2	D3	D4	D5	L1	L2	L3	L4	L5
6	6.35	7		32.5	50	42.5	M4x8	M4	20.2	13.2	3	8.7	8
8	9	9.52	10	32.5	50	42.5	M4x8	M4	20.2	13.2	3	7.8	9
11	12	12.7		35.5	50	42.5	M4x8	M4	20.5	13.5	3	8.5	11
14				35.5	50	42.5	M4x8	M4	24	17	3	10.2	11.5

	i	M _{n 2}	M _{a 2}	M _{p 2}	n ₁	n _{1 max}	φ _S	φ _R	C _t	R _{2 max}	A _{2 max}	η	J _e [kgcm ²]	
		[Nm]	[Nm]	[Nm]	[min ⁻¹]	[min ⁻¹]	[arcmin]	[Nm / arcmin]	[N]	[N]	%		6 ... 9.52	10 ... 14
TR G 060 2_3		18	35	70	3300	4000	5'	3'	3.0	600	700	94	0.20	0.20
TR G 060 2_4		25	40	90	3500	5000	5'	3'	3.0	600	700	94	0.18	0.20
TR G 060 2_5		25	40	90	3500	5000	5'	3'	3.0	600	700	94	0.17	0.19
TR G 060 2_6		25	40	90	3500	5000	5'	3'	3.0	600	700	94	0.17	0.19
TR G 060 2_7		25	40	90	4000	6000	5'	3'	3.0	600	700	94	0.17	0.19
TR G 060 2_10		18	35	70	4000	6000	5'	3'	3.0	600	700	94	0.17	0.18
TR G 060 3_9		18	35	70	3300	4000	5'	3'	2.5	600	700	91	0.20	0.21
TR G 060 3_12		30	45	100	3300	4000	5'	3'	2.5	600	700	91	0.20	0.21
TR G 060 3_15		30	45	100	3300	4000	5'	3'	2.5	600	700	91	0.19	0.21
TR G 060 3_16		30	45	100	3500	5000	5'	3'	2.5	600	700	91	0.18	0.20
TR G 060 3_20		30	45	100	3500	5000	5'	3'	2.5	600	700	91	0.17	0.19
TR G 060 3_25		30	45	100	3500	5000	5'	3'	2.5	600	700	91	0.17	0.18
TR G 060 3_28		30	45	100	4000	6000	5'	3'	2.5	600	700	91	0.17	0.19
TR G 060 3_30		18	35	70	4000	6000	5'	3'	2.5	600	700	91	0.17	0.18
TR G 060 3_35		30	45	100	4000	6000	5'	3'	2.5	600	700	91	0.18	0.19
TR G 060 3_36		25	40	90	3500	5000	5'	3'	2.5	600	700	91	0.18	0.19
TR G 060 3_40		30	45	100	4000	6000	5'	3'	2.5	600	700	91	0.17	0.18
TR G 060 3_50		30	45	100	4000	6000	5'	3'	2.5	600	700	91	0.17	0.18
TR G 060 3_70		30	45	100	4000	6000	5'	3'	2.5	600	700	91	0.17	0.18
TR G 060 3_100		18	35	70	4000	6000	5'	3'	2.5	600	700	91	0.17	0.18
TR G 060 4_48		30	45	100	3500	5000	7'	5'	2.0	600	700	89	0.18	0.20
TR G 060 4_64		30	45	100	3500	5000	7'	5'	2.0	600	700	89	0.18	0.20
TR G 060 4_75		30	45	100	3500	5000	7'	5'	2.0	600	700	89	0.17	0.19
TR G 060 4_80		30	45	100	3500	5000	7'	5'	2.0	600	700	89	0.18	0.20
TR G 060 4_84		30	45	100	4000	6000	7'	5'	2.0	600	700	89	0.17	0.19
TR G 060 4_90		18	35	70	4000	6000	7'	5'	2.0	600	700	89	0.17	0.18
TR G 060 4_120		30	45	100	4000	6000	7'	5'	2.0	600	700	89	0.15	0.17
TR G 060 4_125		30	45	100	3500	5000	7'	5'	2.0	600	700	89	0.17	0.19
TR G 060 4_140		30	45	100	4000	6000	7'	5'	2.0	600	700	89	0.17	0.19
TR G 060 4_150		30	45	100	4000	6000	7'	5'	2.0	600	700	89	0.17	0.18
TR G 060 4_160		30	45	100	4000	6000	7'	5'	2.0	600	700	89	0.17	0.18
TR G 060 4_175		30	45	100	4000	6000	7'	5'	2.0	600	700	89	0.17	0.19
TR G 060 4_200		30	45	100	4000	6000	7'	5'	2.0	600	700	89	0.17	0.18
TR G 060 4_210		30	45	100	4000	6000	7'	5'	2.0	600	700	89	0.17	0.18
TR G 060 4_216		30	45	100	3500	5000	7'	5'	2.0	600	700	89	0.17	0.19
TR G 060 4_250		30	45	100	4000	6000	7'	5'	2.0	600	700	89	0.17	0.18
TR G 060 4_280		30	45	100	4000	6000	7'	5'	2.0	600	700	89	0.17	0.18
TR G 060 4_350		30	45	100	4000	6000	7'	5'	2.0	600	700	89	0.17	0.18
TR G 060 4_400		30	45	100	4000	6000	7'	5'	2.0	600	700	89	0.17	0.18
TR G 060 4_500		30	45	100	4000	6000	7'	5'	2.0	600	700	89	0.17	0.18
TR G 060 4_700		30	45	100	4000	6000	7'	5'	2.0	600	700	89	0.17	0.18
TR G 060 4_1000		18	35	70	4000	6000	7'	5'	2.0	600	700	89	0.17	0.18

S-M-BOR-NL-CAFS-001-V01

TR

TR 080

IS

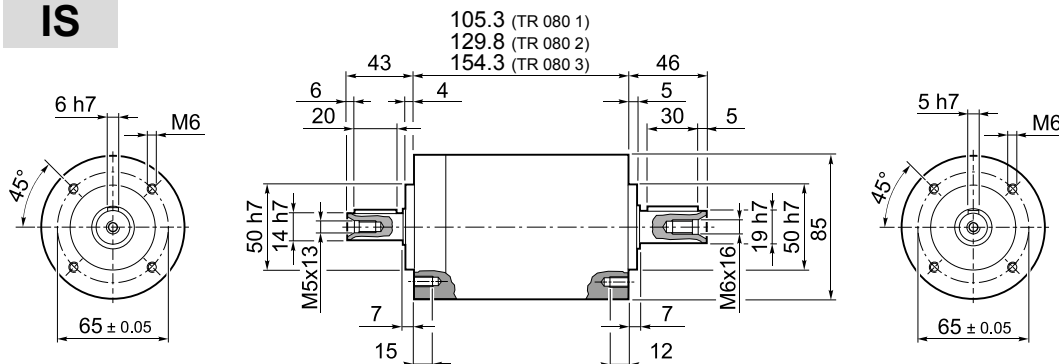

TR 080 1	4.0
TR 080 2	4.6
TR 080 3	5.2

TR

40B1 ... 110B1

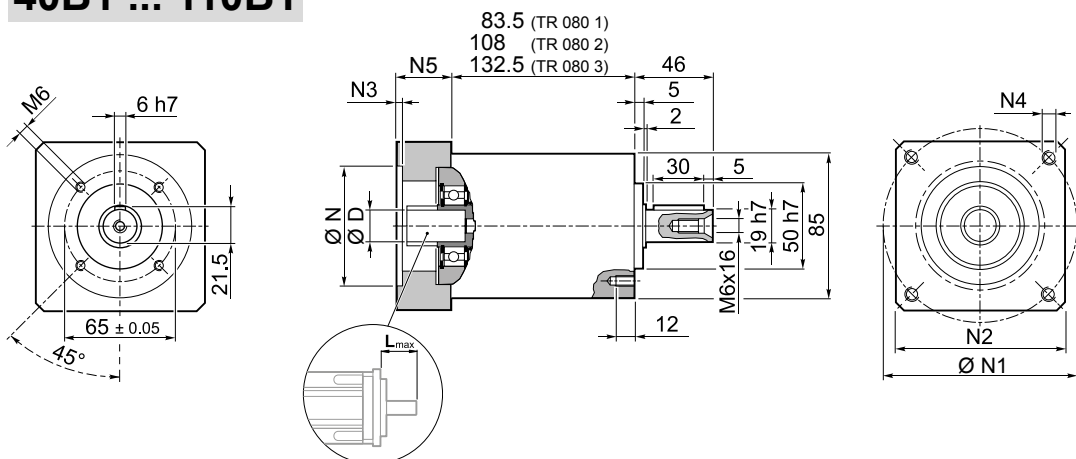

TR 080 1	4.0
TR 080 2	4.6
TR 080 3	5.2

											N	N1	N2	N3	N4	N5	L _{max}		
40B1	8	9	9.52	11	12	12.7	14	-	-	-	-	40	63	80	4	M4x12	34	40	
45A	8	9	9.52	11	12	12.7	-	-	-	-	-	45	63	80	4	M4x12	34	40	
50B1	8	9	9.52	11	12	12.7	14	-	-	-	-	50	65	80	4	M5x16	34	40	
50BH1	8	9	9.52	11	12	12.7	14	-	-	-	-	50	65	80	4	5.5	34	40	
50C1	8	9	9.52	11	12	12.7	14	-	-	-	-	50	70	80	4	M4x10	34	40	
50D	8	9	9.52	11	12	12.7	14	-	-	-	-	50	95	80	4	M6x20	34	40	
55A	8	9	9.52	11	12	12.7	14	15.875	16	17	19	19.05	55.5	125.7	105	4	M6x20	34	40
60A2	8	9	9.52	11	12	12.7	14	-	-	-	-	60	75	80	4	M5x16	34	40	
60AH2	8	9	9.52	11	12	12.7	14	-	-	-	-	60	75	90	4	6.5	34	40	
60B1	8	9	9.52	11	12	12.7	14	15.875	16	-	-	60	85	80	4	M5x16	34	40	
60C1	8	9	9.52	11	12	12.7	14	15.875	16	-	-	60	90	80	4	M5x16	34	40	
70A1	8	9	9.52	11	12	12.7	14	15.875	16	17	19	19.05	70	85	80	4	M6x20	34	40
70AH1	8	9	9.52	11	12	12.7	14	15.875	16	17	19	19.05	70	85	90	4	6.5	34	40
70B1	8	9	9.52	11	12	12.7	14	15.875	16	17	19	19.05	70	90	80	4	M5x16	34	40
73A1	8	9	9.52	11	12	12.7	14	-	-	-	-	73	98.4	85	4	M5x16	34	40	
80A1	8	9	9.52	11	12	12.7	14	15.875	16	17	19	19.05	80	100	90	4	M6x16	34	40
95A	8	9	9.52	11	12	12.7	14	15.875	16	17	19	19.05	95	115	100	4	M8x20	34	40
95B	8	9	9.52	11	12	12.7	14	15.875	16	17	19	19.05	95	130	115	4	M8x20	34	40
110A	8	9	9.52	11	12	12.7	14	15.875	16	17	19	19.05	110	130	115	4	M8x20	34	40
110B	8	9	9.52	11	12	12.7	14	15.875	16	17	19	19.05	110	145	120	6.5	M8x20	44	50
110B1	8	9	9.52	11	12	12.7	14	15.875	16	17	19	19.05	110	145	120	6.5	M8x20	54	60

Please contact us for other motor adapters and input shaft bore.

TR 080

FM

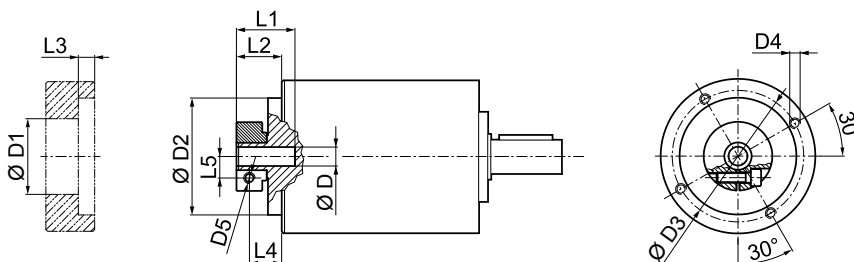

D				D1	D2	D3	D4	D5	L1	L2	L3	L4	L5
8	9	9.52		38	68	76.5	M6x12	M6	32.2	26.3	9.5	19.3	10.5
11	12	12.7		43	68	76.5	M6x12	M6	32.2	26.3	9.5	19.3	12.5
14	15.875	16	17	48	68	76.5	M6x12	M6	32.2	26.3	9.5	19.3	14.5
19	19.05			51	68	76.5	M6x12	M6	32.2	26.3	9.5	19.3	16.5

i	M _{n2} [Nm]	M _{a2} [Nm]	M _{p2} [Nm]	n ₁ [min ⁻¹]	n _{1 max} [min ⁻¹]	φ _S [arcmin]	φ _R [arcmin]	C _t [Nm/arcmin]	R _{1 max} [N]	R _{2 max} [N]	A _{2 max} [N]	η %	J _G [kgcm ²]	
													D	D
													8 ... 12.7	14 ... 19.05
TR 080 1_3	40	80	180	2900	3500	5'	3'	8.0	400	2500	3000	97	0.50	0.59
TR 080 1_4	50	80	200	3100	4500	5'	3'	8.0	400	2500	3000	97	0.34	0.43
TR 080 1_5	50	80	200	3200	4500	5'	3'	8.0	400	2500	3000	97	0.28	0.37
TR 080 1_6	50	80	200	3200	4500	5'	3'	8.0	400	2500	3000	97	0.21	0.30
TR 080 1_7	50	80	200	4000	6000	5'	3'	8.0	400	2500	3000	97	0.23	0.32
TR 080 1_10	40	80	180	4000	6000	5'	3'	8.0	400	2500	3000	97	0.20	0.29
TR 080 2_9	40	80	180	2900	3500	5'	3'	6.5	400	2500	3000	94	0.49	0.58
TR 080 2_12	70	100	250	2900	3500	5'	3'	6.5	400	2500	3000	94	0.47	0.56
TR 080 2_15	70	100	250	2900	3500	5'	3'	6.5	400	2500	3000	94	0.46	0.55
TR 080 2_16	70	100	250	3100	4500	5'	3'	6.5	400	2500	3000	94	0.32	0.41
TR 080 2_20	70	100	250	3200	4500	5'	3'	6.5	400	2500	3000	94	0.27	0.36
TR 080 2_25	70	100	250	3200	4500	5'	3'	6.5	400	2500	3000	94	0.27	0.36
TR 080 2_28	70	100	250	4000	6000	5'	3'	6.5	400	2500	3000	94	0.22	0.31
TR 080 2_30	40	80	180	4000	6000	5'	3'	6.5	400	2500	3000	94	0.20	0.29
TR 080 2_35	70	100	250	4000	6000	5'	3'	6.5	400	2500	3000	94	0.22	0.31
TR 080 2_36	50	80	200	3200	4500	5'	3'	6.5	400	2500	3000	94	0.20	0.29
TR 080 2_40	70	100	250	4000	6000	5'	3'	6.5	400	2500	3000	94	0.20	0.29
TR 080 2_50	70	100	250	4000	6000	5'	3'	6.5	400	2500	3000	94	0.19	0.28
TR 080 2_70	70	100	250	4000	6000	5'	3'	6.5	400	2500	3000	94	0.19	0.28
TR 080 2_100	40	80	180	4000	6000	5'	3'	6.5	400	2500	3000	94	0.19	0.28
TR 080 3_48	70	100	250	3100	4500	7'	5'	5.5	400	2500	3000	91	0.33	0.42
TR 080 3_64	70	100	250	3100	4500	7'	5'	5.5	400	2500	3000	91	0.32	0.41
TR 080 3_75	70	100	250	3200	4500	7'	5'	5.5	400	2500	3000	91	0.27	0.36
TR 080 3_80	70	100	250	3100	4500	7'	5'	5.5	400	2500	3000	91	0.32	0.41
TR 080 3_84	70	100	250	4000	6000	7'	5'	5.5	400	2500	3000	91	0.23	0.32
TR 080 3_90	40	80	180	4000	6000	7'	5'	5.5	400	2500	3000	91	0.20	0.29
TR 080 3_120	70	100	250	4000	6000	7'	5'	5.5	400	2500	3000	91	0.20	0.29
TR 080 3_125	70	100	250	3200	4500	7'	5'	5.5	400	2500	3000	91	0.27	0.36
TR 080 3_140	70	100	250	4000	6000	7'	5'	5.5	400	2500	3000	91	0.22	0.31
TR 080 3_150	70	100	250	4000	6000	7'	5'	5.5	400	2500	3000	91	0.20	0.29
TR 080 3_160	70	100	250	4000	6000	7'	5'	5.5	400	2500	3000	91	0.20	0.29
TR 080 3_175	70	100	250	4000	6000	7'	5'	5.5	400	2500	3000	91	0.22	0.31
TR 080 3_200	70	100	250	4000	6000	7'	5'	5.5	400	2500	3000	91	0.20	0.29
TR 080 3_210	70	100	250	4000	6000	7'	5'	5.5	400	2500	3000	91	0.20	0.29
TR 080 3_216	70	100	250	3200	4500	7'	5'	5.5	400	2500	3000	91	0.20	0.29
TR 080 3_250	70	100	250	4000	6000	7'	5'	5.5	400	2500	3000	91	0.19	0.28
TR 080 3_280	70	100	250	4000	6000	7'	5'	5.5	400	2500	3000	91	0.19	0.28
TR 080 3_350	70	100	250	4000	6000	7'	5'	5.5	400	2500	3000	91	0.19	0.28
TR 080 3_400	70	100	250	4000	6000	7'	5'	5.5	400	2500	3000	91	0.19	0.28
TR 080 3_500	70	100	250	4000	6000	7'	5'	5.5	400	2500	3000	91	0.19	0.28
TR 080 3_700	70	100	250	4000	6000	7'	5'	5.5	400	2500	3000	91	0.19	0.28
TR 080 3_1000	40	80	180	4000	6000	7'	5'	5.5	400	2500	3000	91	0.19	0.28

TR

TR G 080

40B1 ... 110B1

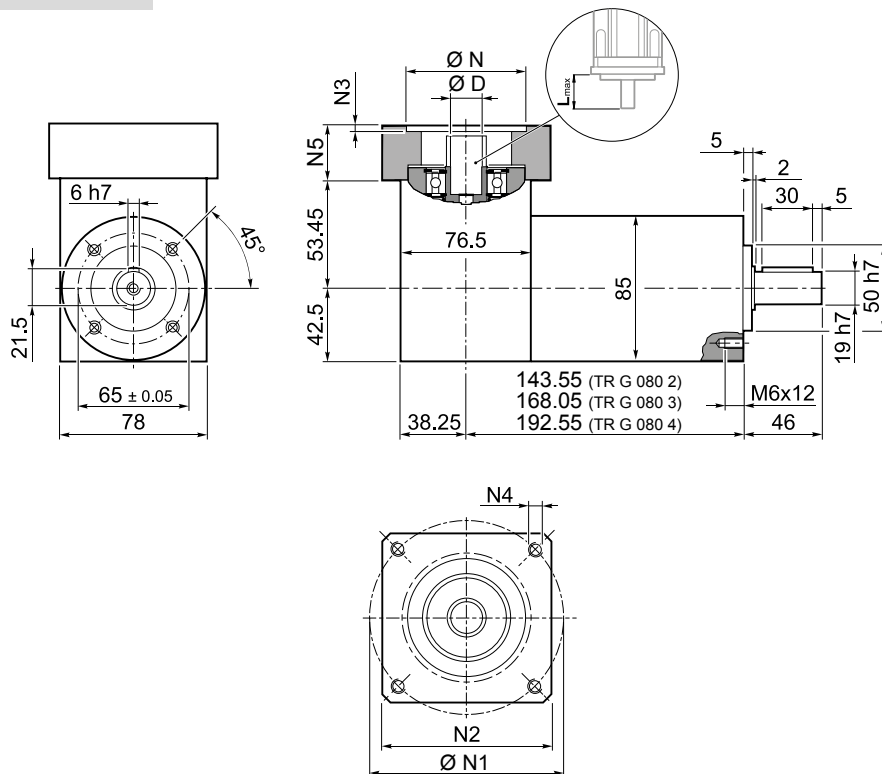

TR G 080 2	5.2
TR G 080 3	5.8
TR G 080 4	6.4

TR

												N	N1	N2	N3	N4	N5	L _{max}	
40B1	8	9	9.52	11	12	12.7	14	-	-	-	-	40	63	80	4	M4x12	34	40	
45A	8	9	9.52	11	12	12.7	-	-	-	-	-	45	63	80	4	M4x12	34	40	
50B1	8	9	9.52	11	12	12.7	14	-	-	-	-	50	65	80	4	M5x16	34	40	
50BH1	8	9	9.52	11	12	12.7	14	-	-	-	-	50	65	80	4	5.5	34	40	
50C1	8	9	9.52	11	12	12.7	14	-	-	-	-	50	70	80	4	M4x10	34	40	
50D	8	9	9.52	11	12	12.7	14	-	-	-	-	50	95	80	4	M6x20	34	40	
55A	8	9	9.52	11	12	12.7	14	15.875	16	17	19	19.05	55.5	125.7	105	4	M6x20	34	40
60A2	8	9	9.52	11	12	12.7	14	-	-	-	-	60	75	80	4	M5x16	34	40	
60AH2	8	9	9.52	11	12	12.7	14	-	-	-	-	60	75	90	4	6.5	34	40	
60B1	8	9	9.52	11	12	12.7	14	15.875	16	-	-	60	85	80	4	M5x16	34	40	
60C1	8	9	9.52	11	12	12.7	14	15.875	16	-	-	60	90	80	4	M5x16	34	40	
70A1	8	9	9.52	11	12	12.7	14	15.875	16	17	19	19.05	70	85	80	4	M6x20	34	40
70AH1	8	9	9.52	11	12	12.7	14	15.875	16	17	19	19.05	70	85	90	4	6.5	34	40
70B1	8	9	9.52	11	12	12.7	14	15.875	16	17	19	19.05	70	90	80	4	M5x16	34	40
73A1	8	9	9.52	11	12	12.7	14	-	-	-	-	73	98.4	85	4	M5x16	34	40	
80A1	8	9	9.52	11	12	12.7	14	15.875	16	17	19	19.05	80	100	90	4	M6x16	34	40
95A	8	9	9.52	11	12	12.7	14	15.875	16	17	19	19.05	95	115	100	4	M8x20	34	40
95B	8	9	9.52	11	12	12.7	14	15.875	16	17	19	19.05	95	130	115	4	M8x20	34	40
110A	8	9	9.52	11	12	12.7	14	15.875	16	17	19	19.05	110	130	115	4	M8x20	34	40
110B	8	9	9.52	11	12	12.7	14	15.875	16	17	19	19.05	110	145	120	6.5	M8x20	44	50
110B1	8	9	9.52	11	12	12.7	14	15.875	16	17	19	19.05	110	145	120	6.5	M8x20	54	60

Please contact us for other motor adapters and input shaft bore.

TR G 080

FM

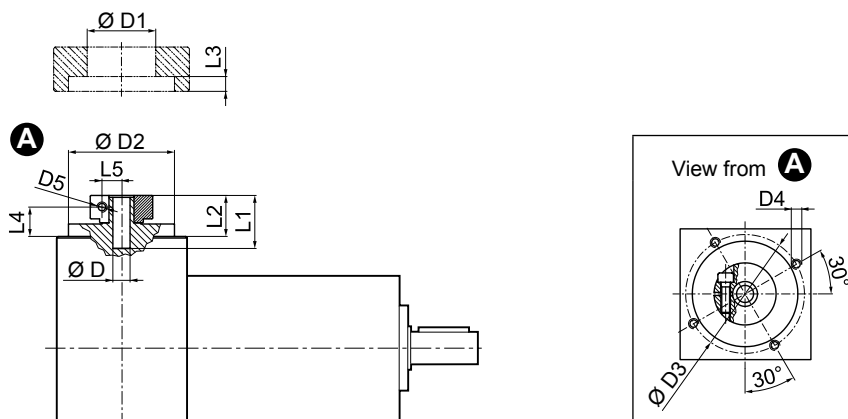

				D1	D2	D3	D4	D5	L1	L2	L3	L4	L5
8	9	9.52		38	68	76.5	M6x12	M6	32.2	26.3	9.5	19.3	10.5
11	12	12.7		43	68	76.5	M6x12	M6	32.2	26.3	9.5	19.3	12.5
14	15.875	16	17	48	68	76.5	M6x12	M6	32.2	26.3	9.5	19.3	14.5
19	19.05			51	68	76.5	M6x12	M6	32.2	26.3	9.5	19.3	16.5

	i	M _{n2}	M _{a2}	M _{p2}	n ₁	n _{1 max}	φ _S	φ _R	C _t	R _{2 max}	A _{2 max}	η	J _G [kgcm ²]	
		[Nm]	[Nm]	[Nm]	[min ⁻¹]	[min ⁻¹]	[arcmin]	[arcmin]	[Nm/arcmin]	[N]	[N]	%		8 ... 12.7
TR G 080 2_3		40	80	180	2900	3500	5'	3'	8.0	2500	3000	94	0.67	0.79
TR G 080 2_4		50	80	200	3100	4500	5'	3'	8.0	2500	3000	94	0.62	0.75
TR G 080 2_5		50	80	200	3200	4500	5'	3'	8.0	2500	3000	94	0.61	0.74
TR G 080 2_6		50	80	200	3200	4500	5'	3'	8.0	2500	3000	94	0.58	0.71
TR G 080 2_7		50	80	200	4000	6000	5'	3'	8.0	2500	3000	94	0.60	0.73
TR G 080 2_10		40	80	180	4000	6000	5'	3'	8.0	2500	3000	94	0.60	0.72
TR G 080 3_9		40	80	180	2900	3500	5'	3'	6.5	2500	3000	91	0.66	0.78
TR G 080 3_12		70	100	250	2900	3500	5'	3'	6.5	2500	3000	91	0.75	0.87
TR G 080 3_15		70	100	250	2900	3500	5'	3'	6.5	2500	3000	91	0.74	0.87
TR G 080 3_16		70	100	250	3100	4500	5'	3'	6.5	2500	3000	91	0.60	0.73
TR G 080 3_20		70	100	250	3200	4500	5'	3'	6.5	2500	3000	91	0.60	0.73
TR G 080 3_25		70	100	250	3200	4500	5'	3'	6.5	2500	3000	91	0.64	0.76
TR G 080 3_28		70	100	250	4000	6000	5'	3'	6.5	2500	3000	91	0.59	0.72
TR G 080 3_30		40	80	180	4000	6000	5'	3'	6.5	2500	3000	91	0.60	0.72
TR G 080 3_35		70	100	250	4000	6000	5'	3'	6.5	2500	3000	91	0.61	0.74
TR G 080 3_36		50	80	200	3200	4500	5'	3'	6.5	2500	3000	91	0.57	0.70
TR G 080 3_40		70	100	250	4000	6000	5'	3'	6.5	2500	3000	91	0.60	0.72
TR G 080 3_50		70	100	250	4000	6000	5'	3'	6.5	2500	3000	91	0.59	0.71
TR G 080 3_70		70	100	250	4000	6000	5'	3'	6.5	2500	3000	91	0.59	0.71
TR G 080 3_100		40	80	180	4000	6000	5'	3'	6.5	2500	3000	91	0.59	0.71
TR G 080 4_48		70	100	250	3100	4500	7'	5'	5.5	2500	3000	89	0.61	0.75
TR G 080 4_64		70	100	250	3100	4500	7'	5'	5.5	2500	3000	89	0.60	0.73
TR G 080 4_75		70	100	250	3200	4500	7'	5'	5.5	2500	3000	89	0.60	0.73
TR G 080 4_80		70	100	250	3100	4500	7'	5'	5.5	2500	3000	89	0.60	0.73
TR G 080 4_84		70	100	250	4000	6000	7'	5'	5.5	2500	3000	89	0.60	0.73
TR G 080 4_90		40	80	180	4000	6000	7'	5'	5.5	2500	3000	89	0.60	0.72
TR G 080 4_120		70	100	250	4000	6000	7'	5'	5.5	2500	3000	89	0.60	0.72
TR G 080 4_125		70	100	250	3200	4500	7'	5'	5.5	2500	3000	89	0.60	0.73
TR G 080 4_140		70	100	250	4000	6000	7'	5'	5.5	2500	3000	89	0.59	0.72
TR G 080 4_150		70	100	250	4000	6000	7'	5'	5.5	2500	3000	89	0.60	0.72
TR G 080 4_160		70	100	250	4000	6000	7'	5'	5.5	2500	3000	89	0.60	0.72
TR G 080 4_175		70	100	250	4000	6000	7'	5'	5.5	2500	3000	89	0.59	0.72
TR G 080 4_200		70	100	250	4000	6000	7'	5'	5.5	2500	3000	89	0.60	0.72
TR G 080 4_210		70	100	250	4000	6000	7'	5'	5.5	2500	3000	89	0.60	0.72
TR G 080 4_216		70	100	250	3200	4500	7'	5'	5.5	2500	3000	89	0.57	0.70
TR G 080 4_250		70	100	250	4000	6000	7'	5'	5.5	2500	3000	89	0.59	0.71
TR G 080 4_280		70	100	250	4000	6000	7'	5'	5.5	2500	3000	89	0.59	0.71
TR G 080 4_350		70	100	250	4000	6000	7'	5'	5.5	2500	3000	89	0.59	0.71
TR G 080 4_400		70	100	250	4000	6000	7'	5'	5.5	2500	3000	89	0.59	0.71
TR G 080 4_500		70	100	250	4000	6000	7'	5'	5.5	2500	3000	89	0.59	0.71
TR G 080 4_700		70	100	250	4000	6000	7'	5'	5.5	2500	3000	89	0.59	0.71
TR G 080 4_1000		40	80	180	4000	6000	7'	5'	5.5	2500	3000	89	0.59	0.71

S-M-BOR-NL-CAFS-001-V01

TR

TR MB 080

40B1 ... 110B1

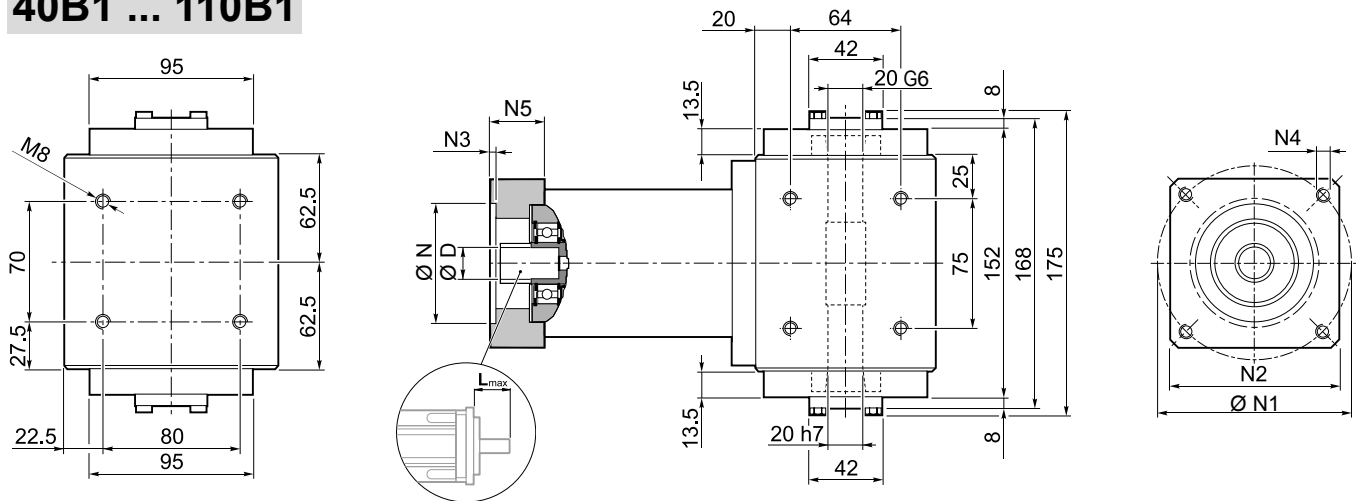

TR

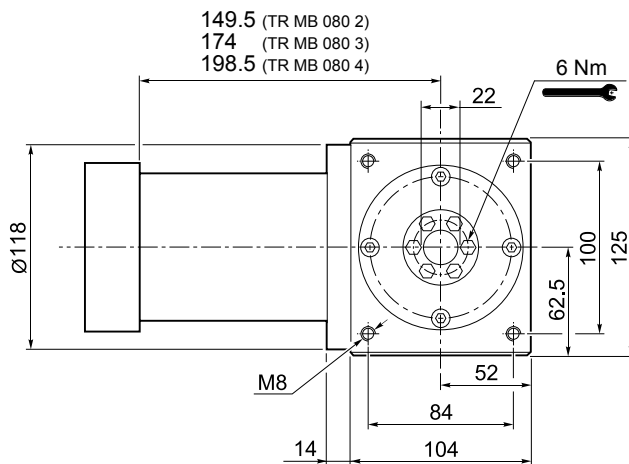

	
TR MB 080 2	14.0
TR MB 080 3	15.0
TR MB 080 4	16.0

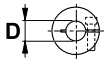
												N	N1	N2	N3	N4	N5	L _{max}
40B1	8	9	9.52	11	12	12.7	14	-	-	-	-	40	63	80	4	M4x12	34	40
45A	8	9	9.52	11	12	12.7	-	-	-	-	-	45	63	80	4	M4x12	34	40
50B1	8	9	9.52	11	12	12.7	14	-	-	-	-	50	65	80	4	M5x16	34	40
50BH1	8	9	9.52	11	12	12.7	14	-	-	-	-	50	65	80	4	5.5	34	40
50C1	8	9	9.52	11	12	12.7	14	-	-	-	-	50	70	80	4	M4x10	34	40
50D	8	9	9.52	11	12	12.7	14	-	-	-	-	50	95	80	4	M6x20	34	40
55A	8	9	9.52	11	12	12.7	14	15.875	16	17	19	55.5	125.7	105	4	M6x20	34	40
60A2	8	9	9.52	11	12	12.7	14	-	-	-	-	60	75	80	4	M5x16	34	40
60AH2	8	9	9.52	11	12	12.7	14	-	-	-	-	60	75	90	4	6.5	34	40
60B1	8	9	9.52	11	12	12.7	14	15.875	16	-	-	60	85	80	4	M5x16	34	40
60C1	8	9	9.52	11	12	12.7	14	15.875	16	-	-	60	90	80	4	M5x16	34	40
70A1	8	9	9.52	11	12	12.7	14	15.875	16	17	19	70	85	80	4	M6x20	34	40
70AH1	8	9	9.52	11	12	12.7	14	15.875	16	17	19	70	85	90	4	6.5	34	40
70B1	8	9	9.52	11	12	12.7	14	15.875	16	17	19	70	90	80	4	M5x16	34	40
73A1	8	9	9.52	11	12	12.7	14	-	-	-	-	73	98.4	85	4	M5x16	34	40
80A1	8	9	9.52	11	12	12.7	14	15.875	16	17	19	80	100	90	4	M6x16	34	40
95A	8	9	9.52	11	12	12.7	14	15.875	16	17	19	95	115	100	4	M8x20	34	40
95B	8	9	9.52	11	12	12.7	14	15.875	16	17	19	95	130	115	4	M8x20	34	40
110A	8	9	9.52	11	12	12.7	14	15.875	16	17	19	110	130	115	4	M8x20	34	40
110B	8	9	9.52	11	12	12.7	14	15.875	16	17	19	110	145	120	6.5	M8x20	44	50
110B1	8	9	9.52	11	12	12.7	14	15.875	16	17	19	110	145	120	6.5	M8x20	54	60

Please contact us for other motor adapters and input shaft bore.

TR MB 080

FM

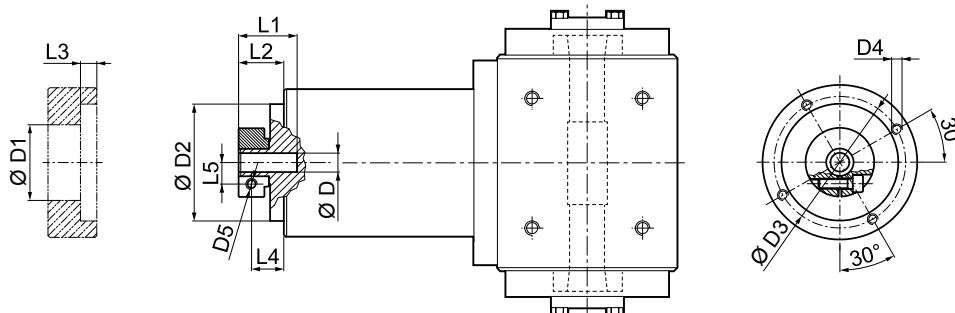

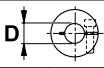
				D1	D2	D3	D4	D5	L1	L2	L3	L4	L5
8	9	9.52		38	68	76.5	M6x12	M6	32.2	26.3	9.5	19.3	10.5
11	12	12.7		43	68	76.5	M6x12	M6	32.2	26.3	9.5	19.3	12.5
14	15.875	16	17	48	68	76.5	M6x12	M6	32.2	26.3	9.5	19.3	14.5
19	19.05			51	68	76.5	M6x12	M6	32.2	26.3	9.5	19.3	16.5

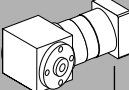
	i	M _{n2}	M _{a2}	M _{p2}	n ₁	n _{1 max}	Ψ _S	Ψ _R	C _t	η	J _G [kgcm ²]	
		[Nm]	[Nm]	[Nm]	[min ⁻¹]	[min ⁻¹]	[arcmin]	[arcmin]	$\frac{Nm}{arcmin}$	%	8 ... 12.7	14 ... 19.05
TR MB 080 2_3		40	80	180	2900	3500	5'	3'	8.0	94	0.50	0.59
TR MB 080 2_4		50	80	200	3100	4500	5'	3'	8.0	94	0.34	0.43
TR MB 080 2_5		50	80	200	3200	4500	5'	3'	8.0	94	0.28	0.37
TR MB 080 2_6		50	80	200	3200	4500	5'	3'	8.0	94	0.21	0.30
TR MB 080 2_7		50	80	200	4000	6000	5'	3'	8.0	94	0.23	0.32
TR MB 080 2_10		40	80	180	4000	6000	5'	3'	8.0	94	0.20	0.29
TR MB 080 3_9		40	80	180	2900	3500	5'	3'	6.5	91	0.49	0.58
TR MB 080 3_12		70	100	250	2900	3500	5'	3'	6.5	91	0.47	0.56
TR MB 080 3_15		70	100	250	2900	3500	5'	3'	6.5	91	0.46	0.55
TR MB 080 3_16		70	100	250	3100	4500	5'	3'	6.5	91	0.32	0.41
TR MB 080 3_20		70	100	250	3200	4500	5'	3'	6.5	91	0.27	0.36
TR MB 080 3_25		70	100	250	3200	4500	5'	3'	6.5	91	0.27	0.36
TR MB 080 3_28		70	100	250	4000	6000	5'	3'	6.5	91	0.22	0.31
TR MB 080 3_30		40	80	180	4000	6000	5'	3'	6.5	91	0.20	0.29
TR MB 080 3_35		70	100	250	4000	6000	5'	3'	6.5	91	0.22	0.31
TR MB 080 3_36		50	80	200	3200	4500	5'	3'	6.5	91	0.20	0.29
TR MB 080 3_40		70	100	250	4000	6000	5'	3'	6.5	91	0.20	0.29
TR MB 080 3_50		70	100	250	4000	6000	5'	3'	6.5	91	0.19	0.28
TR MB 080 3_70		70	100	250	4000	6000	5'	3'	6.5	91	0.19	0.28
TR MB 080 3_100		40	80	180	4000	6000	5'	3'	6.5	91	0.19	0.28
TR MB 080 4_48		70	100	250	3100	4500	7'	5'	5.5	89	0.33	0.42
TR MB 080 4_64		70	100	250	3100	4500	7'	5'	5.5	89	0.32	0.41
TR MB 080 4_75		70	100	250	3200	4500	7'	5'	5.5	89	0.27	0.36
TR MB 080 4_80		70	100	250	3100	4500	7'	5'	5.5	89	0.32	0.41
TR MB 080 4_84		70	100	250	4000	6000	7'	5'	5.5	89	0.23	0.32
TR MB 080 4_90		40	80	180	4000	6000	7'	5'	5.5	89	0.20	0.29
TR MB 080 4_120		70	100	250	4000	6000	7'	5'	5.5	89	0.20	0.29
TR MB 080 4_125		70	100	250	3200	4500	7'	5'	5.5	89	0.27	0.36
TR MB 080 4_140		70	100	250	4000	6000	7'	5'	5.5	89	0.22	0.31
TR MB 080 4_150		70	100	250	4000	6000	7'	5'	5.5	89	0.20	0.29
TR MB 080 4_160		70	100	250	4000	6000	7'	5'	5.5	89	0.20	0.29
TR MB 080 4_175		70	100	250	4000	6000	7'	5'	5.5	89	0.22	0.31
TR MB 080 4_200		70	100	250	4000	6000	7'	5'	5.5	89	0.20	0.29
TR MB 080 4_210		70	100	250	4000	6000	7'	5'	5.5	89	0.20	0.29
TR MB 080 4_216		70	100	250	3200	4500	7'	5'	5.5	89	0.20	0.29
TR MB 080 4_250		70	100	250	4000	6000	7'	5'	5.5	89	0.19	0.28
TR MB 080 4_280		70	100	250	4000	6000	7'	5'	5.5	89	0.19	0.28
TR MB 080 4_350		70	100	250	4000	6000	7'	5'	5.5	89	0.19	0.28
TR MB 080 4_400		70	100	250	4000	6000	7'	5'	5.5	89	0.19	0.28
TR MB 080 4_500		70	100	250	4000	6000	7'	5'	5.5	89	0.19	0.28
TR MB 080 4_700		70	100	250	4000	6000	7'	5'	5.5	89	0.19	0.28
TR MB 080 4_1000		40	80	180	4000	6000	7'	5'	5.5	89	0.19	0.28

TR

TR 105

IS

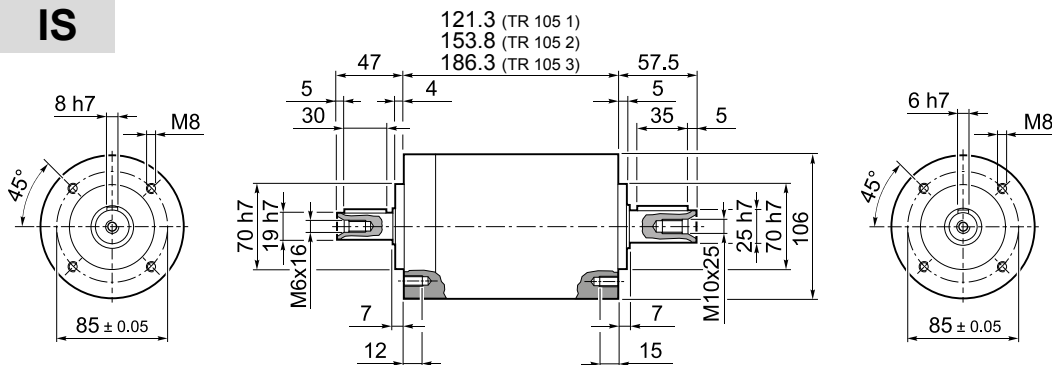

TR 105 1	6.5
TR 105 2	8.5
TR 105 3	10.5

TR

50D ... 130A1

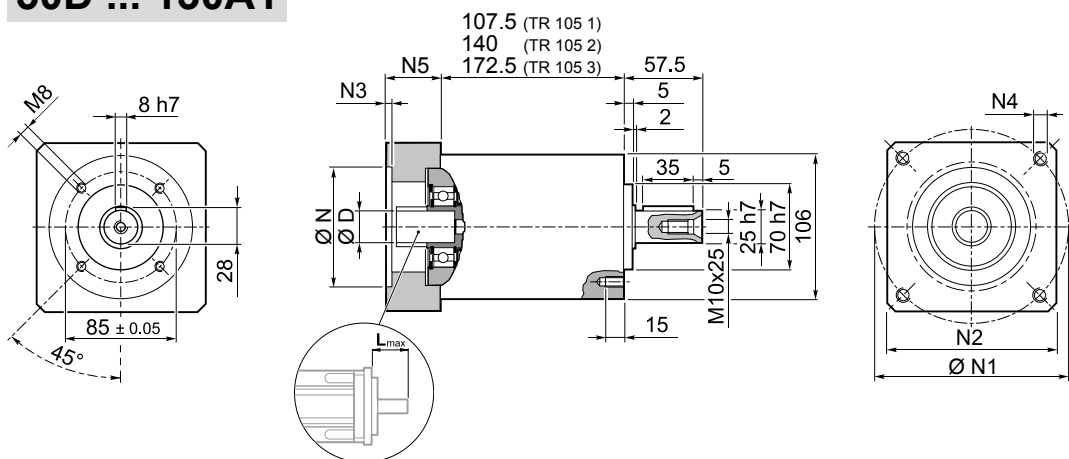

TR 105 1	6.5
TR 105 2	8.5
TR 105 3	10.5

											N	N1	N2	N3	N4	N5	L _{max}	
50D	11	12	12.7	14	15	15.875	16	19	-	-	-	50	95	100	5	M6x14	28	40
55A	11	12	12.7	14	15	15.875	16	19	-	-	-	55	125.7	105	5	M6x16	28	40
60A2	11	12	12.7	14	15	15.875	16	19	-	-	-	60	75	100	6.5	M5x14	28	40
60AH2	11	12	12.7	14	15	15.875	16	19	-	-	-	60	75	100	4	6.5	33	40
60B1	11	12	12.7	14	15	15.875	16	19	-	-	-	60	85	100	6.5	M5x14	28	40
70A1	11	12	12.7	14	15	15.875	16	19	-	-	-	70	85	100	6.5	M6x14	28	40
70AH1	11	12	12.7	14	15	15.875	16	19	-	-	-	70	85	100	4	6.5	33	40
70B1	11	12	12.7	14	15	15.875	16	19	-	-	-	70	90	100	6.5	M5x12	28	40
80A1	11	12	12.7	14	15	15.875	16	19	-	-	-	80	100	100	6.5	M6x16	28	40
80AH1	11	12	12.7	14	15	15.875	16	19	-	-	-	80	100	100	4	6.5	33	40
95A	11	12	12.7	14	15	15.875	16	19	-	-	-	95	115	100	6.5	M8x18	28	40
95A1	11	12	12.7	14	15	15.875	16	19	22	24	-	95	115	100	6.5	M8x18	38	50
95B	11	12	12.7	14	15	15.875	16	19	-	-	-	95	130	115	6.5	M8x18	28	40
110A	11	12	12.7	14	15	15.875	16	19	-	-	-	110	130	115	6.5	M8x18	28	40
110A1	11	12	12.7	14	15	15.875	16	19	22	24	-	110	130	115	6.5	M8x20	38	50
110B	11	12	12.7	14	15	15.875	16	19	22	24	-	110	145	120	6.5	M8x20	38	50
110B1	11	12	12.7	14	15	15.875	16	19	22	24	28	110	145	120	6.5	M8x20	48	60
130A	11	12	12.7	14	15	15.875	16	19	22	24	-	130	165	140	6.5	M10x20	38	50
130A1	11	12	12.7	14	15	15.875	16	19	22	24	28	130	165	140	6.5	M10x25	48	60

Please contact us for other motor adapters and input shaft bore.

TR 105

FM

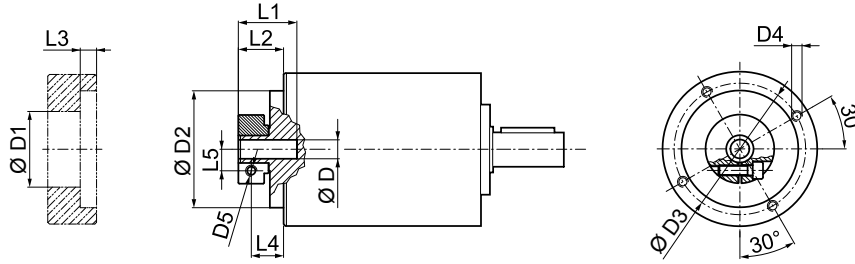

D				D1	D2	D3	D4	D5	L1	L2	L3	L4	L5
11	12	12.7		43	90	98	M6x15	M6	31.5	19.5	7.6	12	12.5
14	15	15.875	16	48	90	98	M6x15	M6	31.5	19.5	7.6	12	14.5
19				51	90	98	M6x15	M6	31.5	19.5	7.6	12	16.5
22	24			56.5	90	98	M6x15	M6	35	23	7.6	12	19
28				67	90	98	M6x15	M8	35	23	7.6	14	22.5
32				71	90	98	M6x15	M8	37	25	7.6	16	24.5

i	M _{n2} [Nm]	M _{a2} [Nm]	M _{p2} [Nm]	n ₁ [min ⁻¹]	n _{1 max} [min ⁻¹]	φ _S [arcmin]	φ _R [arcmin]	C _t [Nm/arcmin]	R _{1 max} [N]	R _{2 max} [N]	A _{2 max} [N]	η %	J _G [kgcm ²]			
													D			
													11 ... 12.7	14 ... 19	22 - 24	28 - 32
TR 105 1_3	100	180	360	2500	3500	5'	3'	24.0	600	3800	4000	97	1.70	1.78	2.22	2.59
TR 105 1_4	140	210	450	2800	4500	5'	3'	24.0	600	3800	4000	97	0.99	1.06	1.51	1.87
TR 105 1_5	140	210	450	3000	4500	5'	3'	24.0	600	3800	4000	97	0.72	0.79	1.23	1.60
TR 105 1_6	140	210	450	3000	4500	5'	3'	24.0	600	3800	4000	97	0.36	0.43	0.88	1.24
TR 105 1_7	140	210	450	3500	5000	5'	3'	24.0	600	3800	4000	97	0.47	0.55	0.99	1.35
TR 105 1_10	100	180	360	3500	5000	5'	3'	24.0	600	3800	4000	97	0.33	0.41	0.85	1.21
TR 105 2_9	100	180	360	2500	3500	5'	3'	21.5	600	3800	4000	94	1.58	1.63	2.07	2.44
TR 105 2_12	170	250	600	2500	3500	5'	3'	21.5	600	3800	4000	94	1.52	1.59	2.03	2.40
TR 105 2_15	170	250	600	2500	3500	5'	3'	21.5	600	3800	4000	94	1.47	1.55	1.99	2.36
TR 105 2_16	170	250	600	2800	4500	5'	3'	21.5	600	3800	4000	94	0.87	0.95	1.39	1.76
TR 105 2_20	170	250	600	3000	4500	5'	3'	21.5	600	3800	4000	94	0.86	0.93	1.37	1.74
TR 105 2_25	170	250	600	3000	4500	5'	3'	21.5	600	3800	4000	94	0.63	0.71	1.15	1.51
TR 105 2_28	170	250	600	3500	5000	5'	3'	21.5	600	3800	4000	94	0.43	0.51	0.95	1.32
TR 105 2_30	100	180	360	3500	5000	5'	3'	21.5	600	3800	4000	94	0.32	0.40	0.84	1.20
TR 105 2_35	170	250	600	3500	5000	5'	3'	21.5	600	3800	4000	94	0.43	0.50	0.95	1.31
TR 105 2_36	140	210	450	3000	4500	5'	3'	21.5	600	3800	4000	94	0.32	0.39	0.84	1.20
TR 105 2_40	170	250	600	3500	5000	5'	3'	21.5	600	3800	4000	94	0.31	0.39	0.83	1.20
TR 105 2_50	170	250	600	3500	5000	5'	3'	21.5	600	3800	4000	94	0.31	0.39	0.83	1.19
TR 105 2_70	170	250	600	3500	5000	5'	3'	21.5	600	3800	4000	94	0.31	0.38	0.83	1.19
TR 105 2_100	100	180	360	3500	5000	5'	3'	21.5	600	3800	4000	94	0.31	0.38	0.83	1.19
TR 105 3_48	170	250	600	2800	4500	7'	5'	18.0	600	3800	4000	91	0.91	0.98	1.42	1.79
TR 105 3_64	170	250	600	2800	4500	7'	5'	18.0	600	3800	4000	91	0.87	0.94	1.38	1.75
TR 105 3_75	170	250	600	3000	4500	7'	5'	18.0	600	3800	4000	91	0.66	0.74	1.18	1.55
TR 105 3_80	170	250	600	2800	4500	7'	5'	18.0	600	3800	4000	91	0.86	0.94	1.38	1.75
TR 105 3_84	170	250	600	3500	5000	7'	5'	18.0	600	3800	4000	91	0.44	0.52	0.96	1.33
TR 105 3_90	100	180	360	3500	5000	7'	5'	18.0	600	3800	4000	91	0.32	0.39	0.84	1.20
TR 105 3_120	170	250	600	3500	5000	7'	5'	18.0	600	3800	4000	91	0.32	0.39	0.84	1.20
TR 105 3_125	170	250	600	3000	4500	7'	5'	18.0	600	3800	4000	91	0.63	0.70	1.15	1.51
TR 105 3_140	170	250	600	3500	5000	7'	5'	18.0	600	3800	4000	91	0.43	0.51	0.95	1.32
TR 105 3_150	170	250	600	3500	5000	7'	5'	18.0	600	3800	4000	91	0.32	0.39	0.84	1.20
TR 105 3_160	170	250	600	3500	5000	7'	5'	18.0	600	3800	4000	91	0.31	0.39	0.83	1.21
TR 105 3_175	170	250	600	3500	5000	7'	5'	18.0	600	3800	4000	91	0.43	0.50	0.95	1.31
TR 105 3_200	170	250	600	3500	5000	7'	5'	18.0	600	3800	4000	91	0.31	0.39	0.83	1.20
TR 105 3_210	170	250	600	3500	5000	7'	5'	18.0	600	3800	4000	91	0.32	0.39	0.84	1.20
TR 105 3_216	170	250	600	3000	4500	7'	5'	18.0	600	3800	4000	91	0.31	0.39	0.83	1.20
TR 105 3_250	170	250	600	3500	5000	7'	5'	18.0	600	3800	4000	91	0.31	0.39	0.83	1.19
TR 105 3_280	170	250	600	3500	5000	7'	5'	18.0	600	3800	4000	91	0.31	0.38	0.83	1.19
TR 105 3_350	170	250	600	3500	5000	7'	5'	18.0	600	3800	4000	91	0.31	0.38	0.83	1.19
TR 105 3_400	170	250	600	3500	5000	7'	5'	18.0	600	3800	4000	91	0.31	0.38	0.83	1.19
TR 105 3_500	170	250	600	3500	5000	7'	5'	18.0	600	3800	4000	91	0.31	0.38	0.83	1.19
TR 105 3_700	170	250	600	3500	5000	7'	5'	18.0	600	3800	4000	91	0.31	0.38	0.83	1.19
TR 105 3_1000	100	180	360	3500	5000	7'	5'	18.0	600	3800	4000	91	0.31	0.38	0.83	1.19

S-M-BOR-NL-CAFS-001-V01

TR

TR G 105

50D ... 130A1

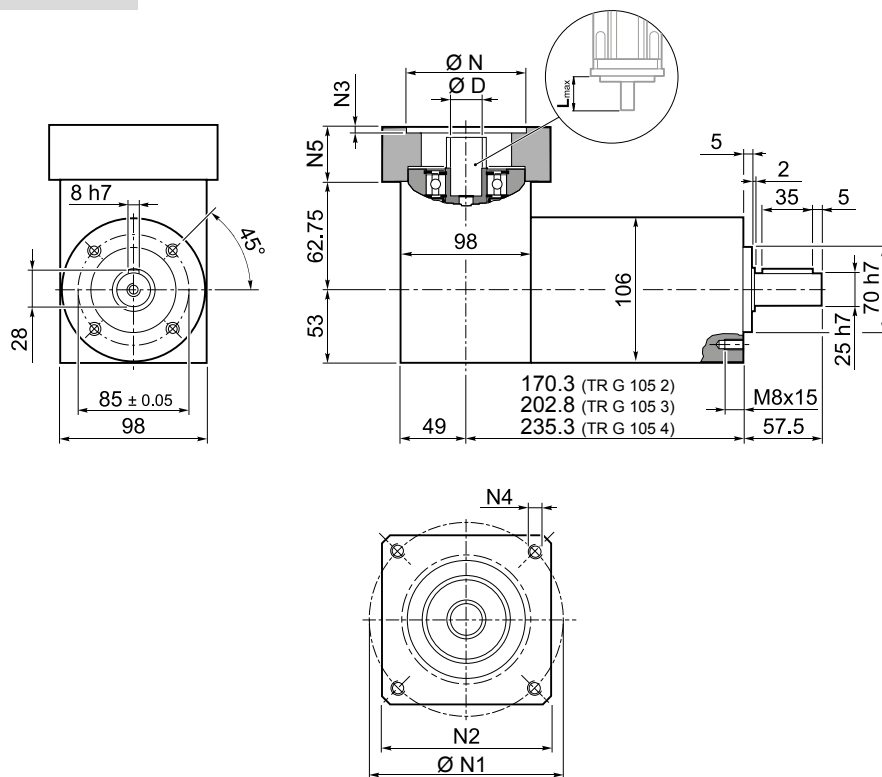

TR G 105 2	8.5
TR G 105 3	10.5
TR G 105 4	12.5

TR

													N	N1	N2	N3	N4	N5	L _{max}
50D	11	12	12.7	14	15	15.875	16	19	-	-	-	-	50	95	100	5	M6x14	28	40
55A	11	12	12.7	14	15	15.875	16	19	-	-	-	-	55	125.7	105	5	M6x16	28	40
60A2	11	12	12.7	14	15	15.875	16	19	-	-	-	-	60	75	100	6.5	M5x14	28	40
60AH2	11	12	12.7	14	15	15.875	16	19	-	-	-	-	60	75	100	4	6.5	33	40
60B1	11	12	12.7	14	15	15.875	16	19	-	-	-	-	60	85	100	6.5	M5x14	28	40
70A1	11	12	12.7	14	15	15.875	16	19	-	-	-	-	70	85	100	6.5	M6x14	28	40
70AH1	11	12	12.7	14	15	15.875	16	19	-	-	-	-	70	85	100	4	6.5	33	40
70B1	11	12	12.7	14	15	15.875	16	19	-	-	-	-	70	90	100	6.5	M5x12	28	40
80A1	11	12	12.7	14	15	15.875	16	19	-	-	-	-	80	100	100	6.5	M6x16	28	40
80AH1	11	12	12.7	14	15	15.875	16	19	-	-	-	-	80	100	100	4	6.5	33	40
95A	11	12	12.7	14	15	15.875	16	19	-	-	-	-	95	115	100	6.5	M8x18	28	40
95A1	11	12	12.7	14	15	15.875	16	19	22	24	-	-	95	115	100	6.5	M8x18	38	50
95B	11	12	12.7	14	15	15.875	16	19	-	-	-	-	95	130	115	6.5	M8x18	28	40
110A	11	12	12.7	14	15	15.875	16	19	-	-	-	-	110	130	115	6.5	M8x18	28	40
110A1	11	12	12.7	14	15	15.875	16	19	22	24	-	-	110	130	115	6.5	M8x20	38	50
110B	11	12	12.7	14	15	15.875	16	19	22	24	-	-	110	145	120	6.5	M8x20	38	50
110B1	11	12	12.7	14	15	15.875	16	19	22	24	28	-	110	145	120	6.5	M8x20	48	60
130A	11	12	12.7	14	15	15.875	16	19	22	24	-	-	130	165	140	6.5	M10x20	38	50
130A1	11	12	12.7	14	15	15.875	16	19	22	24	28	32	130	165	140	6.5	M10x25	48	60

Please contact us for other motor adapters and input shaft bore.

TR G 105

FM

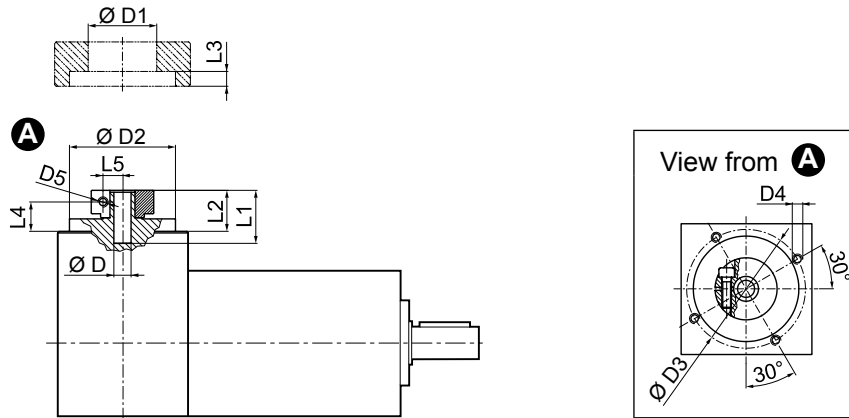

				D1	D2	D3	D4	D5	L1	L2	L3	L4	L5
11	12	12.7		43	90	98	M6x15	M6	31.5	19.5	7.6	12	12.5
14	15	15.875	16	48	90	98	M6x15	M6	31.5	19.5	7.6	12	14.5
19				51	90	98	M6x15	M6	31.5	19.5	7.6	12	16.5
22	24			56.5	90	98	M6x15	M6	35	23	7.6	12	19
28				67	90	98	M6x15	M8	35	23	7.6	14	22.5
32				71	90	98	M6x15	M8	37	25	7.6	16	24.5

	i	M _{n2} [Nm]	M _{a2} [Nm]	M _{p2} [Nm]	n ₁ [min ⁻¹]	n _{1 max} [min ⁻¹]	φ _S [arcmin]	φ _R [arcmin]	C _t [Nm/arcmin]	R _{2 max} [N]	A _{2 max} [N]	η %	J _G [kgcm ²]			
													11 ... 12.7	14 ... 19	22 - 24	28 - 32
TR G 105 2_3	100	180	360	2500	3500	5'	3'	24.0	3800	4000	94	1.85	2.01	2.33	3.07	
TR G 105 2_4	140	210	450	2800	4500	5'	3'	24.0	3800	4000	94	1.14	1.29	1.62	2.35	
TR G 105 2_5	140	210	450	3000	4500	5'	3'	24.0	3800	4000	94	1.07	1.21	1.34	2.08	
TR G 105 2_6	140	210	450	3000	4500	5'	3'	24.0	3800	4000	94	0.87	1.02	1.16	1.89	
TR G 105 2_7	140	210	450	3500	5000	5'	3'	24.0	3800	4000	94	0.98	1.14	1.27	2.00	
TR G 105 2_10	100	180	360	3500	5000	5'	3'	24.0	3800	4000	94	0.94	1.09	1.23	1.95	
TR G 105 3_9	100	180	360	2500	3500	5'	3'	21.5	3800	4000	91	1.76	1.86	2.18	2.92	
TR G 105 3_12	170	250	600	2500	3500	5'	3'	21.5	3800	4000	91	1.60	1.75	2.14	2.88	
TR G 105 3_15	170	250	600	2500	3500	5'	3'	21.5	3800	4000	91	1.57	1.73	2.10	2.84	
TR G 105 3_16	170	250	600	2800	4500	5'	3'	21.5	3800	4000	91	1.02	1.18	1.50	2.24	
TR G 105 3_20	170	250	600	3000	4500	5'	3'	21.5	3800	4000	91	1.20	1.35	1.48	2.22	
TR G 105 3_25	170	250	600	3000	4500	5'	3'	21.5	3800	4000	91	1.13	1.29	1.42	2.15	
TR G 105 3_28	170	250	600	3500	5000	5'	3'	21.5	3800	4000	91	0.94	1.10	1.23	1.97	
TR G 105 3_30	100	180	360	3500	5000	5'	3'	21.5	3800	4000	91	0.93	1.08	1.22	1.94	
TR G 105 3_35	170	250	600	3500	5000	5'	3'	21.5	3800	4000	91	1.02	1.17	1.31	2.04	
TR G 105 3_36	140	210	450	3000	4500	5'	3'	21.5	3800	4000	91	0.83	0.98	1.12	1.85	
TR G 105 3_40	170	250	600	3500	5000	5'	3'	21.5	3800	4000	91	0.96	1.11	1.25	1.98	
TR G 105 3_50	170	250	600	3500	5000	5'	3'	21.5	3800	4000	91	0.96	1.11	1.25	1.98	
TR G 105 3_70	170	250	600	3500	5000	5'	3'	21.5	3800	4000	91	0.92	1.06	1.21	1.93	
TR G 105 3_100	100	180	360	3500	5000	5'	3'	21.5	3800	4000	91	0.92	1.06	1.21	1.93	
TR G 105 4_48	170	250	600	2800	4500	7'	5'	18.0	3800	4000	89	1.06	1.21	1.53	2.27	
TR G 105 4_64	170	250	600	2800	4500	7'	5'	18.0	3800	4000	89	1.02	1.17	1.49	2.23	
TR G 105 4_75	170	250	600	3000	4500	7'	5'	18.0	3800	4000	89	1.00	1.16	1.29	2.03	
TR G 105 4_80	170	250	600	2800	4500	7'	5'	18.0	3800	4000	89	1.01	1.17	1.49	2.23	
TR G 105 4_84	170	250	600	3500	5000	7'	5'	18.0	3800	4000	89	0.95	1.11	1.24	1.98	
TR G 105 4_90	100	180	360	3500	5000	7'	5'	18.0	3800	4000	89	0.93	1.07	1.22	1.94	
TR G 105 4_120	170	250	600	3500	5000	7'	5'	18.0	3800	4000	89	0.93	1.07	1.22	1.94	
TR G 105 4_125	170	250	600	3000	4500	7'	5'	18.0	3800	4000	89	0.97	1.12	1.26	1.99	
TR G 105 4_140	170	250	600	3500	5000	7'	5'	18.0	3800	4000	89	0.94	1.10	1.23	1.97	
TR G 105 4_150	170	250	600	3500	5000	7'	5'	18.0	3800	4000	89	0.93	1.07	1.22	1.94	
TR G 105 4_160	170	250	600	3500	5000	7'	5'	18.0	3800	4000	89	0.92	1.07	1.21	1.96	
TR G 105 4_175	170	250	600	3500	5000	7'	5'	18.0	3800	4000	89	0.94	1.09	1.23	1.96	
TR G 105 4_200	170	250	600	3500	5000	7'	5'	18.0	3800	4000	89	0.92	1.07	1.21	1.94	
TR G 105 4_210	170	250	600	3500	5000	7'	5'	18.0	3800	4000	89	0.93	1.07	1.22	1.94	
TR G 105 4_216	170	250	600	3000	4500	7'	5'	18.0	3800	4000	89	0.83	0.98	1.11	1.85	
TR G 105 4_250	170	250	600	3500	5000	7'	5'	18.0	3800	4000	89	0.92	1.07	1.21	1.93	
TR G 105 4_280	170	250	600	3500	5000	7'	5'	18.0	3800	4000	89	0.92	1.06	1.21	1.93	
TR G 105 4_350	170	250	600	3500	5000	7'	5'	18.0	3800	4000	89	0.92	1.06	1.21	1.93	
TR G 105 4_400	170	250	600	3500	5000	7'	5'	18.0	3800	4000	89	0.92	1.06	1.21	1.93	
TR G 105 4_500	170	250	600	3500	5000	7'	5'	18.0	3800	4000	89	0.92	1.06	1.21	1.93	
TR G 105 4_700	170	250	600	3500	5000	7'	5'	18.0	3800	4000	89	0.92	1.06	1.21	1.93	
TR G 105 4_1000	100	180	360	3500	5000	7'	5'	18.0	3800	4000	89	0.92	1.06	1.21	1.93	

TR MB 105

50D ... 130A1

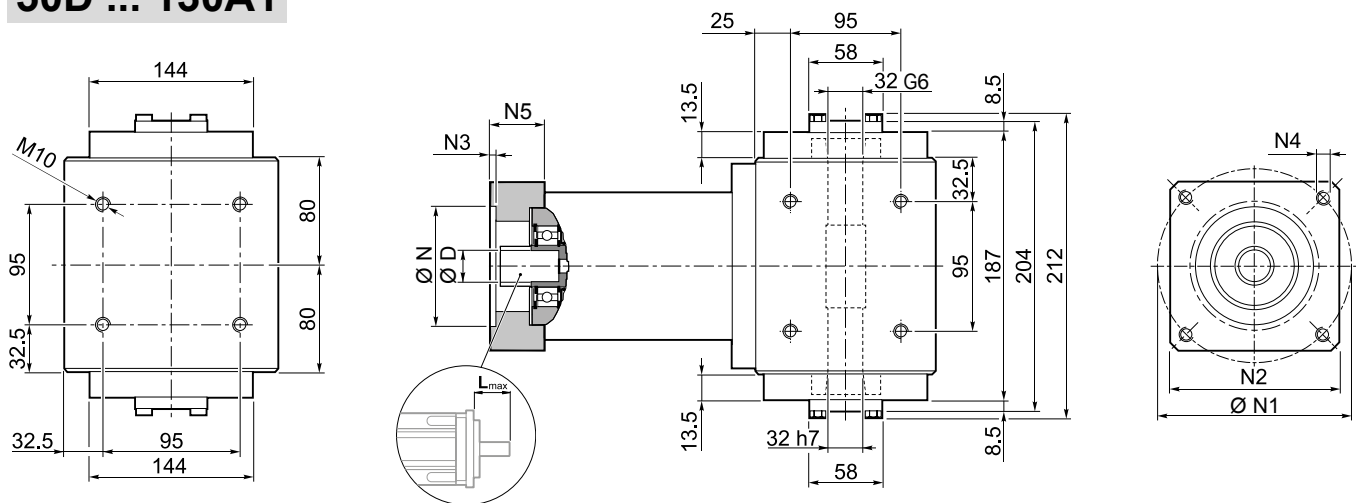

TR

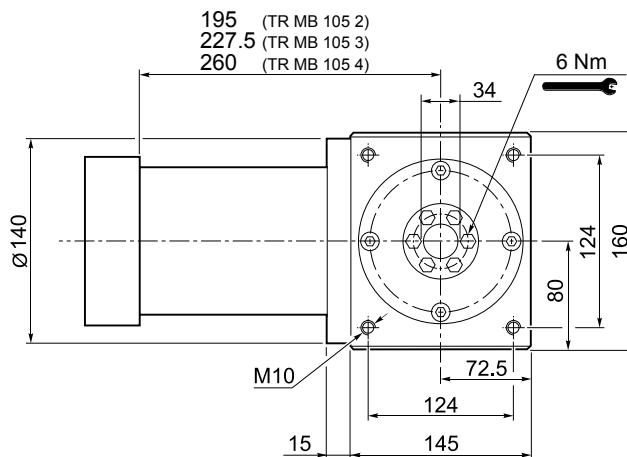

TR MB 105 2	32
TR MB 105 3	34
TR MB 105 4	36

												N	N1	N2	N3	N4	N5	L _{max}	
50D	11	12	12.7	14	15	15.875	16	19	-	-	-	-	50	95	100	5	M6x14	28	40
55A	11	12	12.7	14	15	15.875	16	19	-	-	-	-	55	125.7	105	5	M6x16	28	40
60A2	11	12	12.7	14	15	15.875	16	19	-	-	-	-	60	75	100	6.5	M5x14	28	40
60AH2	11	12	12.7	14	15	15.875	16	19	-	-	-	-	60	75	100	4	6.5	33	40
60B1	11	12	12.7	14	15	15.875	16	19	-	-	-	-	60	85	100	6.5	M5x14	28	40
70A1	11	12	12.7	14	15	15.875	16	19	-	-	-	-	70	85	100	6.5	M6x14	28	40
70AH1	11	12	12.7	14	15	15.875	16	19	-	-	-	-	70	85	100	4	6.5	33	40
70B1	11	12	12.7	14	15	15.875	16	19	-	-	-	-	70	90	100	6.5	M5x12	28	40
80A1	11	12	12.7	14	15	15.875	16	19	-	-	-	-	80	100	100	6.5	M6x16	28	40
80AH1	11	12	12.7	14	15	15.875	16	19	-	-	-	-	80	100	100	4	6.5	33	40
95A	11	12	12.7	14	15	15.875	16	19	-	-	-	-	95	115	100	6.5	M8x18	28	40
95A1	11	12	12.7	14	15	15.875	16	19	22	24	-	-	95	115	100	6.5	M8x18	38	50
95B	11	12	12.7	14	15	15.875	16	19	-	-	-	-	95	130	115	6.5	M8x18	28	40
110A	11	12	12.7	14	15	15.875	16	19	-	-	-	-	110	130	115	6.5	M8x18	28	40
110A1	11	12	12.7	14	15	15.875	16	19	22	24	-	-	110	130	115	6.5	M8x20	38	50
110B	11	12	12.7	14	15	15.875	16	19	22	24	-	-	110	145	120	6.5	M8x20	38	50
110B1	11	12	12.7	14	15	15.875	16	19	22	24	28	-	110	145	120	6.5	M8x20	48	60
130A	11	12	12.7	14	15	15.875	16	19	22	24	-	-	130	165	140	6.5	M10x20	38	50
130A1	11	12	12.7	14	15	15.875	16	19	22	24	28	32	130	165	140	6.5	M10x25	48	60

Please contact us for other motor adapters and input shaft bore.

TR MB 105

FM

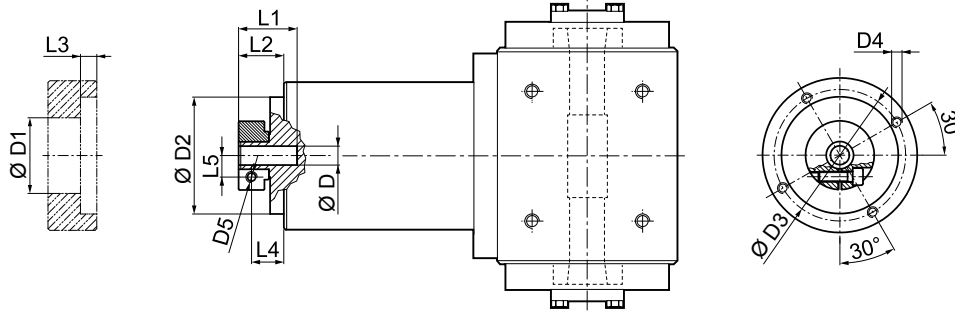

D				D1	D2	D3	D4	D5	L1	L2	L3	L4	L5
11	12	12.7		43	90	98	M6x15	M6	31.5	19.5	7.6	12	12.5
14	15	15.875	16	48	90	98	M6x15	M6	31.5	19.5	7.6	12	14.5
19				51	90	98	M6x15	M6	31.5	19.5	7.6	12	16.5
22	24			56.5	90	98	M6x15	M6	35	23	7.6	12	19
28				67	90	98	M6x15	M8	35	23	7.6	14	22.5
32				71	90	98	M6x15	M8	37	25	7.6	16	24.5

i	M _{n2} [Nm]	M _{a2} [Nm]	M _{p2} [Nm]	n ₁ [min ⁻¹]	n _{1 max} [min ⁻¹]	φ _S [arcmin]	φ _R [arcmin]	C _t [Nm/arcmin]	η %	J _G [kgcm ²]			
										D	11 ... 12.7	14 ... 19	22 - 24
TR MB 105 2_3	100	180	360	2500	3500	5'	3'	24.0	94	1.70	1.78	2.22	2.59
TR MB 105 2_4	140	210	450	2800	4500	5'	3'	24.0	94	0.99	1.06	1.51	1.87
TR MB 105 2_5	140	210	450	3000	4500	5'	3'	24.0	94	0.72	0.79	1.23	1.60
TR MB 105 2_6	140	210	450	3000	4500	5'	3'	24.0	94	0.36	0.43	0.88	1.24
TR MB 105 2_7	140	210	450	3500	5000	5'	3'	24.0	94	0.47	0.55	0.99	1.35
TR MB 105 2_10	100	180	360	3500	5000	5'	3'	24.0	94	0.33	0.41	0.85	1.21
TR MB 105 3_9	100	180	360	2500	3500	5'	3'	21.5	91	1.58	1.63	2.07	2.44
TR MB 105 3_12	170	250	600	2500	3500	5'	3'	21.5	91	1.52	1.59	2.03	2.40
TR MB 105 3_15	170	250	600	2500	3500	5'	3'	21.5	91	1.47	1.55	1.99	2.36
TR MB 105 3_16	170	250	600	2800	4500	5'	3'	21.5	91	0.87	0.95	1.39	1.76
TR MB 105 3_20	170	250	600	3000	4500	5'	3'	21.5	91	0.86	0.93	1.37	1.74
TR MB 105 3_25	170	250	600	3000	4500	5'	3'	21.5	91	0.63	0.71	1.15	1.51
TR MB 105 3_28	170	250	600	3500	5000	5'	3'	21.5	91	0.43	0.51	0.95	1.32
TR MB 105 3_30	100	180	360	3500	5000	5'	3'	21.5	91	0.32	0.40	0.84	1.20
TR MB 105 3_35	170	250	600	3500	5000	5'	3'	21.5	91	0.43	0.50	0.95	1.31
TR MB 105 3_36	140	210	450	3000	4500	5'	3'	21.5	91	0.32	0.39	0.84	1.20
TR MB 105 3_40	170	250	600	3500	5000	5'	3'	21.5	91	0.31	0.39	0.83	1.20
TR MB 105 3_50	170	250	600	3500	5000	5'	3'	21.5	91	0.31	0.39	0.83	1.19
TR MB 105 3_70	170	250	600	3500	5000	5'	3'	21.5	91	0.31	0.38	0.83	1.19
TR MB 105 3_100	100	180	360	3500	5000	5'	3'	21.5	91	0.31	0.38	0.83	1.19
TR MB 105 4_48	170	250	600	2800	4500	7'	5'	18.0	89	0.91	0.98	1.42	1.79
TR MB 105 4_64	170	250	600	2800	4500	7'	5'	18.0	89	0.87	0.94	1.38	1.75
TR MB 105 4_75	170	250	600	3000	4500	7'	5'	18.0	89	0.66	0.74	1.18	1.55
TR MB 105 4_80	170	250	600	2800	4500	7'	5'	18.0	89	0.86	0.94	1.38	1.75
TR MB 105 4_84	170	250	600	3500	5000	7'	5'	18.0	89	0.44	0.52	0.96	1.33
TR MB 105 4_90	100	180	360	3500	5000	7'	5'	18.0	89	0.32	0.39	0.84	1.20
TR MB 105 4_120	170	250	600	3500	5000	7'	5'	18.0	89	0.32	0.39	0.84	1.20
TR MB 105 4_125	170	250	600	3000	4500	7'	5'	18.0	89	0.63	0.70	1.15	1.51
TR MB 105 4_140	170	250	600	3500	5000	7'	5'	18.0	89	0.43	0.51	0.95	1.32
TR MB 105 4_150	170	250	600	3500	5000	7'	5'	18.0	89	0.32	0.39	0.84	1.20
TR MB 105 4_160	170	250	600	3500	5000	7'	5'	18.0	89	0.31	0.39	0.83	1.21
TR MB 105 4_175	170	250	600	3500	5000	7'	5'	18.0	89	0.43	0.50	0.95	1.31
TR MB 105 4_200	170	250	600	3500	5000	7'	5'	18.0	89	0.31	0.39	0.83	1.20
TR MB 105 4_210	170	250	600	3500	5000	7'	5'	18.0	89	0.32	0.39	0.84	1.20
TR MB 105 4_216	170	250	600	3000	4500	7'	5'	18.0	89	0.31	0.39	0.83	1.20
TR MB 105 4_250	170	250	600	3500	5000	7'	5'	18.0	89	0.31	0.39	0.83	1.19
TR MB 105 4_280	170	250	600	3500	5000	7'	5'	18.0	89	0.31	0.38	0.83	1.19
TR MB 105 4_350	170	250	600	3500	5000	7'	5'	18.0	89	0.31	0.38	0.83	1.19
TR MB 105 4_400	170	250	600	3500	5000	7'	5'	18.0	89	0.31	0.38	0.83	1.19
TR MB 105 4_500	170	250	600	3500	5000	7'	5'	18.0	89	0.31	0.38	0.83	1.19
TR MB 105 4_700	170	250	600	3500	5000	7'	5'	18.0	89	0.31	0.38	0.83	1.19
TR MB 105 4_1000	100	180	360	3500	5000	7'	5'	18.0	89	0.31	0.38	0.83	1.19

S-M-BOR-NL-CAFS-001-V01

TR

TR 130

IS

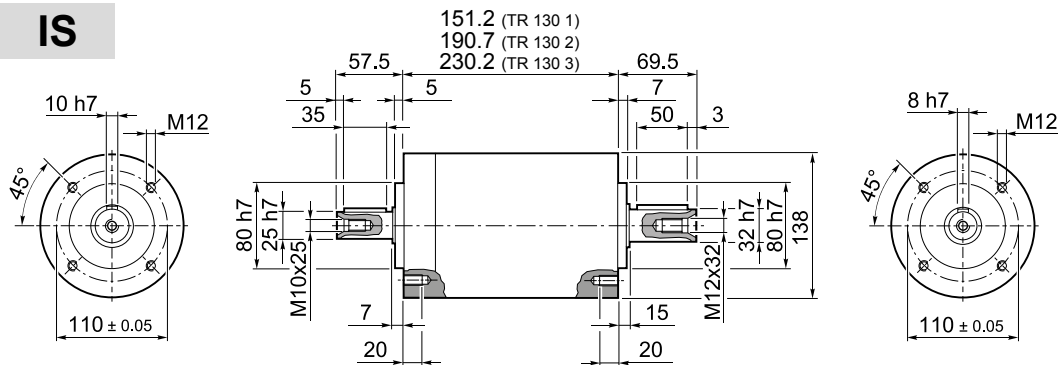

TR 130 1	12.0
TR 130 2	15.5
TR 130 3	18.5

TR

55A1 ... 180A1

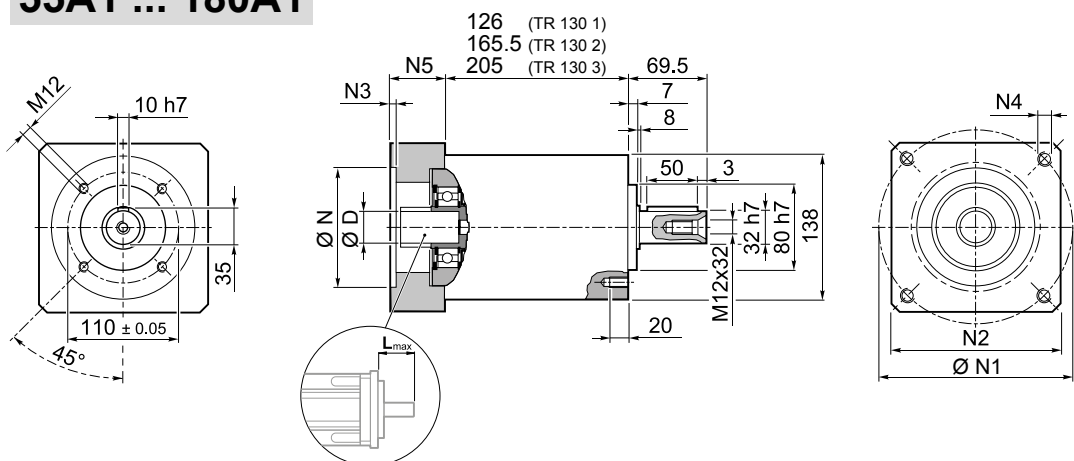

TR 130 1	12.0
TR 130 2	15.5
TR 130 3	18.5

											N	N1	N2	N3	N4	N5	L _{max}
55A1	14	15.875	16	19	-	-	-	-	-	-	55.5	125.7	130	4	M6x15	39.5	50
80A2	14	15.875	16	19	-	-	-	-	-	-	80	100	130	4	M6x15	39.5	50
95A1	14	15.875	16	19	22	24	-	-	-	-	95	115	130	4	M8x20	39.5	50
110A1	14	15.875	16	19	22	24	-	-	-	-	110	130	130	4	M8x20	39.5	50
110B1	14	15.875	16	19	22	24	-	-	-	-	110	145	130	6.5	M8x20	49.5	60
114A0	14	15.875	16	19	22	24	-	-	-	-	114.3	200	170	5.5	M12x25	39.5	50
114A	14	15.875	16	19	22	24	28	32	35	38	114.3	200	170	5.5	M12x25	69.5	80
130A	14	15.875	16	19	22	24	-	-	-	-	130	165	140	4	M10x20	39.5	50
130A1	14	15.875	16	19	22	24	28	32	-	-	130	165	140	4	M10x20	49.5	60
180A	14	15.875	16	19	22	24	28	32	-	-	180	215	190	5.5	M14x25	49.5	60
180A1	14	15.875	16	19	22	24	28	32	35	38	180	215	190	5.5	M14x25	69.5	80

Please contact us for other motor adapters and input shaft bore.

TR 130

FM

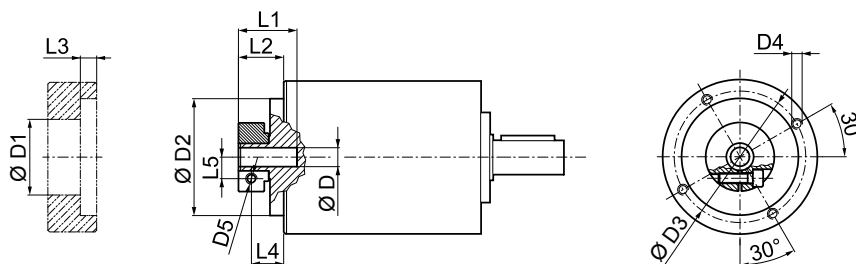

D			D1	D2	D3	D4	D5	L1	L2	L3	L4	L5
14	15.875	16	48	113	125.5	M8x15	M6	40	27.5	6	20	14.5
19			51	113	125.5	M8x15	M6	40	27.5	6	20	16.5
22	24		56.5	113	125.5	M8x15	M6	41	28.5	6	19.5	19
28			67	113	125.5	M8x15	M8	41	28.5	6	19.5	22.5
32			71	113	125.5	M8x15	M8	41	28.5	6	19.5	24.5
35			73	113	125.5	M8x15	M8	50	37.5	11.25	26	26
38			77.5	113	125.5	M8x15	M8	50	37.5	11.25	26	28

i	M _{n2} [Nm]	M _{a2} [Nm]	M _{p2} [Nm]	n ₁ [min ⁻¹]	n _{1 max} [min ⁻¹]	φ _S [arcmin]	φ _R [arcmin]	C _t [Nm/arcmin]	R _{1 max} [N]	R _{2 max} [N]	A _{2 max} [N]	η [%]	J _G [kgcm ²]			
													14 ... 19	22 - 24	28 - 32	35 - 38
TR 130 1_3	215	400	800	2100	3000	5'	3'	45.0	800	5500	6500	97	5.25	5.46	5.81	7.16
TR 130 1_4	380	600	1100	2400	3500	5'	3'	45.0	800	5500	6500	97	3.06	3.26	3.61	4.97
TR 130 1_5	380	600	1100	2900	3500	5'	3'	45.0	800	5500	6500	97	2.22	2.42	2.77	4.13
TR 130 1_6	380	600	1100	2900	3500	5'	3'	45.0	800	5500	6500	97	1.19	1.40	1.75	3.10
TR 130 1_7	380	600	1100	3200	4000	5'	3'	45.0	800	5500	6500	97	1.47	1.68	2.03	3.38
TR 130 1_10	215	400	800	3200	4000	5'	3'	45.0	800	5500	6500	97	1.04	1.25	1.60	2.95
TR 130 2_9	215	400	800	2100	3000	5'	3'	38.5	800	5500	6500	94	4.82	5.02	5.37	6.72
TR 130 2_12	450	700	1300	2100	3000	5'	3'	38.5	800	5500	6500	94	4.57	4.78	5.13	6.48
TR 130 2_15	450	700	1300	2100	3000	5'	3'	38.5	800	5500	6500	94	4.48	4.69	5.04	6.39
TR 130 2_16	450	700	1300	2400	3500	5'	3'	38.5	800	5500	6500	94	2.67	2.88	3.23	4.58
TR 130 2_20	450	700	1300	2900	3500	5'	3'	38.5	800	5500	6500	94	1.97	2.18	2.53	3.88
TR 130 2_25	450	700	1300	2900	3500	5'	3'	38.5	800	5500	6500	94	1.94	2.15	2.50	3.85
TR 130 2_28	450	700	1300	3200	4000	5'	3'	38.5	800	5500	6500	94	1.34	1.55	1.90	3.25
TR 130 2_30	215	400	800	3200	4000	5'	3'	38.5	800	5500	6500	94	1.00	1.21	1.56	2.91
TR 130 2_35	450	700	1300	3200	4000	5'	3'	38.5	800	5500	6500	94	1.33	1.53	1.88	3.24
TR 130 2_36	380	600	1100	2900	3500	5'	3'	38.5	800	5500	6500	94	1.05	1.26	1.61	2.96
TR 130 2_40	450	700	1300	3200	4000	5'	3'	38.5	800	5500	6500	94	0.98	1.19	1.54	2.89
TR 130 2_50	450	700	1300	3200	4000	5'	3'	38.5	800	5500	6500	94	0.97	1.18	1.53	2.88
TR 130 2_70	450	700	1300	3200	4000	5'	3'	38.5	800	5500	6500	94	0.96	1.17	1.52	2.87
TR 130 2_100	215	400	800	3200	4000	5'	3'	38.5	800	5500	6500	94	0.96	1.17	1.52	2.87
TR 130 3_48	450	700	1300	2400	3500	7'	5'	30.0	800	5500	6500	91	2.77	2.98	3.33	4.68
TR 130 3_64	450	700	1300	2400	3500	7'	5'	30.0	800	5500	6500	91	2.65	2.86	3.21	4.56
TR 130 3_75	450	700	1300	2900	3500	7'	5'	30.0	800	5500	6500	91	2.03	2.24	2.59	3.94
TR 130 3_80	450	700	1300	2400	3500	7'	5'	30.0	800	5500	6500	91	2.65	2.85	3.20	4.56
TR 130 3_84	450	700	1300	3200	4000	7'	5'	30.0	800	5500	6500	91	1.37	1.58	1.93	3.28
TR 130 3_90	215	400	800	3200	4000	7'	5'	30.0	800	5500	6500	91	1.00	1.20	1.55	2.91
TR 130 3_120	450	700	1300	3200	4000	7'	5'	30.0	800	5500	6500	91	0.99	1.20	1.55	2.90
TR 130 3_125	450	700	1300	2900	3500	7'	5'	30.0	800	5500	6500	91	1.93	2.13	2.48	3.84
TR 130 3_140	450	700	1300	3200	4000	7'	5'	30.0	800	5500	6500	91	1.34	1.54	1.89	3.25
TR 130 3_150	450	700	1300	3200	4000	7'	5'	30.0	800	5500	6500	91	0.99	1.20	1.55	2.90
TR 130 3_160	450	700	1300	3200	4000	7'	5'	30.0	800	5500	6500	91	0.98	1.18	1.53	2.89
TR 130 3_175	450	700	1300	3200	4000	7'	5'	30.0	800	5500	6500	91	1.32	1.53	1.88	3.23
TR 130 3_200	450	700	1300	3200	4000	7'	5'	30.0	800	5500	6500	91	0.97	1.18	1.53	2.88
TR 130 3_210	450	700	1300	3200	4000	7'	5'	30.0	800	5500	6500	91	0.99	1.20	1.55	2.90
TR 130 3_216	450	700	1300	2900	3500	7'	5'	30.0	800	5500	6500	91	1.05	1.26	1.61	2.96
TR 130 3_250	450	700	1300	3200	4000	7'	5'	30.0	800	5500	6500	91	0.97	1.18	1.53	2.88
TR 130 3_280	450	700	1300	3200	4000	7'	5'	30.0	800	5500	6500	91	0.96	1.17	1.52	2.87
TR 130 3_350	450	700	1300	3200	4000	7'	5'	30.0	800	5500	6500	91	0.96	1.17	1.52	2.87
TR 130 3_400	450	700	1300	3200	4000	7'	5'	30.0	800	5500	6500	91	0.96	1.17	1.52	2.87
TR 130 3_500	450	700	1300	3200	4000	7'	5'	30.0	800	5500	6500	91	0.96	1.17	1.52	2.87
TR 130 3_700	450	700	1300	3200	4000	7'	5'	30.0	800	5500	6500	91	0.96	1.17	1.52	2.87
TR 130 3_1000	215	400	800	3200	4000	7'	5'	30.0	800	5500	6500	91	0.96	1.17	1.52	2.87

TR

TR G 130

55A1 ... 180A1

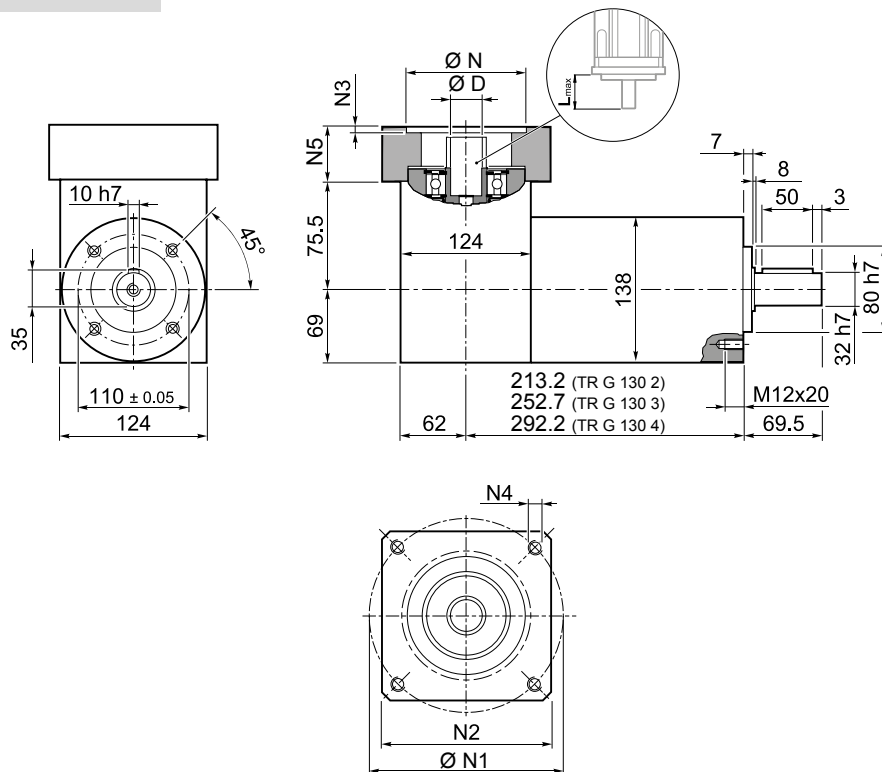

TR G 130 2	16.0
TR G 130 3	19.5
TR G 130 4	22.5

TR

											N	N1	N2	N3	N4	N5	L _{max}
55A1	14	15.875	16	19	-	-	-	-	-	-	55.5	125.7	130	4	M6x15	39.5	50
80A2	14	15.875	16	19	-	-	-	-	-	-	80	100	130	4	M6x15	39.5	50
95A1	14	15.875	16	19	22	24	-	-	-	-	95	115	130	4	M8x20	39.5	50
110A1	14	15.875	16	19	22	24	-	-	-	-	110	130	130	4	M8x20	39.5	50
110B1	14	15.875	16	19	22	24	-	-	-	-	110	145	130	6.5	M8x20	49.5	60
114A0	14	15.875	16	19	22	24	-	-	-	-	114.3	200	170	5.5	M12x25	39.5	50
114A	14	15.875	16	19	22	24	28	32	35	38	114.3	200	170	5.5	M12x25	69.5	80
130A	14	15.875	16	19	22	24	-	-	-	-	130	165	140	4	M10x20	39.5	50
130A1	14	15.875	16	19	22	24	28	32	-	-	130	165	140	4	M10x20	49.5	60
180A	14	15.875	16	19	22	24	28	32	-	-	180	215	190	5.5	M14x25	49.5	60
180A1	14	15.875	16	19	22	24	28	32	35	38	180	215	190	5.5	M14x25	69.5	80

Please contact us for other motor adapters and input shaft bore.

TR G 130

FM

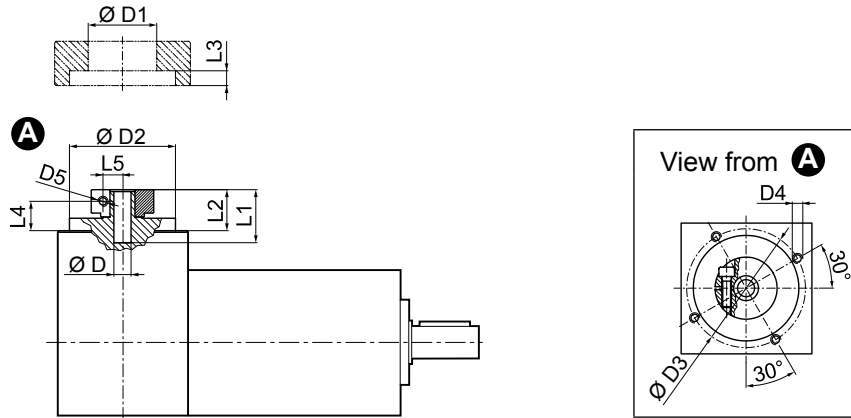

D		D1	D2	D3	D4	D5	L1	L2	L3	L4	L5
14	15.875	48	113	125.5	M8x15	M6	40	27.5	6	20	14.5
19		51	113	125.5	M8x15	M6	40	27.5	6	20	16.5
22	24	56.5	113	125.5	M8x15	M6	41	28.5	6	19.5	19
28		67	113	125.5	M8x15	M8	41	28.5	6	19.5	22.5
32		71	113	125.5	M8x15	M8	41	28.5	6	19.5	24.5
35		73	113	125.5	M8x15	M8	50	37.5	11.25	26	26
38		77.5	113	125.5	M8x15	M8	50	37.5	11.25	26	28

i	M _{n2} [Nm]	M _{a2} [Nm]	M _{p2} [Nm]	n ₁ [min ⁻¹]	n _{1 max} [min ⁻¹]	φ _S [arcmin]	φ _R [arcmin]	C _t [Nm/arcmin]	R _{2 max} [N]	A _{2 max} [N]	η %	J _G [kgcm ²]			
												14 ... 19	22 - 24	28 - 32	35 - 38
TR G 130 2_3	215	400	800	2100	3000	5'	3'	45.0	5500	6500	94	7.09	7.28	7.66	10.37
TR G 130 2_4	380	600	1100	2400	3500	5'	3'	45.0	5500	6500	94	4.90	5.08	5.46	8.18
TR G 130 2_5	380	600	1100	2900	3500	5'	3'	45.0	5500	6500	94	4.81	4.99	5.38	8.10
TR G 130 2_6	380	600	1100	2900	3500	5'	3'	45.0	5500	6500	94	4.45	4.64	5.03	7.73
TR G 130 2_7	380	600	1100	3200	4000	5'	3'	45.0	5500	6500	94	4.73	4.92	5.31	8.01
TR G 130 2_10	215	400	800	3200	4000	5'	3'	45.0	5500	6500	94	4.68	4.88	5.26	7.97
TR G 130 3_9	215	400	800	2100	3000	5'	3'	38.5	5500	6500	91	6.66	6.84	7.22	9.93
TR G 130 3_12	450	700	1300	2100	3000	5'	3'	38.5	5500	6500	91	6.25	6.45	6.84	9.54
TR G 130 3_15	450	700	1300	2100	3000	5'	3'	38.5	5500	6500	91	6.25	6.44	6.83	9.53
TR G 130 3_16	450	700	1300	2400	3500	5'	3'	38.5	5500	6500	91	4.51	4.70	5.08	7.79
TR G 130 3_20	450	700	1300	2900	3500	5'	3'	38.5	5500	6500	91	4.56	5.36	5.75	8.45
TR G 130 3_25	450	700	1300	2900	3500	5'	3'	38.5	5500	6500	91	5.13	4.72	5.11	7.82
TR G 130 3_28	450	700	1300	3200	4000	5'	3'	38.5	5500	6500	91	4.60	4.79	5.18	7.88
TR G 130 3_30	215	400	800	3200	4000	5'	3'	38.5	5500	6500	91	4.64	4.84	5.22	7.93
TR G 130 3_35	450	700	1300	3200	4000	5'	3'	38.5	5500	6500	91	4.92	5.10	5.49	8.20
TR G 130 3_36	380	600	1100	2900	3500	5'	3'	38.5	5500	6500	91	4.31	4.50	4.89	7.59
TR G 130 3_40	450	700	1300	3200	4000	5'	3'	38.5	5500	6500	91	4.77	4.96	5.35	8.05
TR G 130 3_50	450	700	1300	3200	4000	5'	3'	38.5	5500	6500	91	4.76	4.96	5.34	8.05
TR G 130 3_70	450	700	1300	3200	4000	5'	3'	38.5	5500	6500	91	4.60	4.80	5.18	7.89
TR G 130 3_100	215	400	800	3200	4000	5'	3'	38.5	5500	6500	91	4.60	4.80	5.18	7.89
TR G 130 4_48	450	700	1300	2400	3500	7'	5'	30.0	5500	6500	89	4.61	4.81	5.18	7.89
TR G 130 4_64	450	700	1300	2400	3500	7'	5'	30.0	5500	6500	89	4.49	4.68	5.06	7.77
TR G 130 4_75	450	700	1300	2900	3500	7'	5'	30.0	5500	6500	89	4.62	4.81	5.20	7.91
TR G 130 4_80	450	700	1300	2400	3500	7'	5'	30.0	5500	6500	89	4.49	4.67	5.05	7.77
TR G 130 4_84	450	700	1300	3200	4000	7'	5'	30.0	5500	6500	89	4.63	4.82	5.21	7.91
TR G 130 4_90	215	400	800	3200	4000	7'	5'	30.0	5500	6500	89	4.64	4.83	5.21	7.93
TR G 130 4_120	450	700	1300	3200	4000	7'	5'	30.0	5500	6500	89	4.63	4.83	5.21	7.92
TR G 130 4_125	450	700	1300	2900	3500	7'	5'	30.0	5500	6500	89	4.52	4.70	5.09	7.81
TR G 130 4_140	450	700	1300	3200	4000	7'	5'	30.0	5500	6500	89	4.60	4.78	5.17	7.88
TR G 130 4_150	450	700	1300	3200	4000	7'	5'	30.0	5500	6500	89	4.63	4.83	5.21	7.92
TR G 130 4_160	450	700	1300	3200	4000	7'	5'	30.0	5500	6500	89	4.62	4.81	5.19	7.91
TR G 130 4_175	450	700	1300	3200	4000	7'	5'	30.0	5500	6500	89	4.58	4.77	5.16	7.86
TR G 130 4_200	450	700	1300	3200	4000	7'	5'	30.0	5500	6500	89	4.61	4.81	5.19	7.90
TR G 130 4_210	450	700	1300	3200	4000	7'	5'	30.0	5500	6500	89	4.63	4.83	5.21	7.92
TR G 130 4_216	450	700	1300	2900	3500	7'	5'	30.0	5500	6500	89	4.31	4.50	4.89	7.59
TR G 130 4_250	450	700	1300	3200	4000	7'	5'	30.0	5500	6500	89	4.61	4.81	5.19	7.90
TR G 130 4_280	450	700	1300	3200	4000	7'	5'	30.0	5500	6500	89	4.60	4.80	5.18	7.89
TR G 130 4_350	450	700	1300	3200	4000	7'	5'	30.0	5500	6500	89	4.60	4.80	5.18	7.89
TR G 130 4_400	450	700	1300	3200	4000	7'	5'	30.0	5500	6500	89	4.60	4.80	5.18	7.89
TR G 130 4_500	450	700	1300	3200	4000	7'	5'	30.0	5500	6500	89	4.60	4.80	5.18	7.89
TR G 130 4_700	450	700	1300	3200	4000	7'	5'	30.0	5500	6500	89	4.60	4.80	5.18	7.89
TR G 130 4_1000	215	400	800	3200	4000	7'	5'	30.0	5500	6500	89	4.60	4.80	5.18	7.89

S-M-BOR-NL-CAFS-001-V01

TR

TR MB 130

55A1 ... 180A1

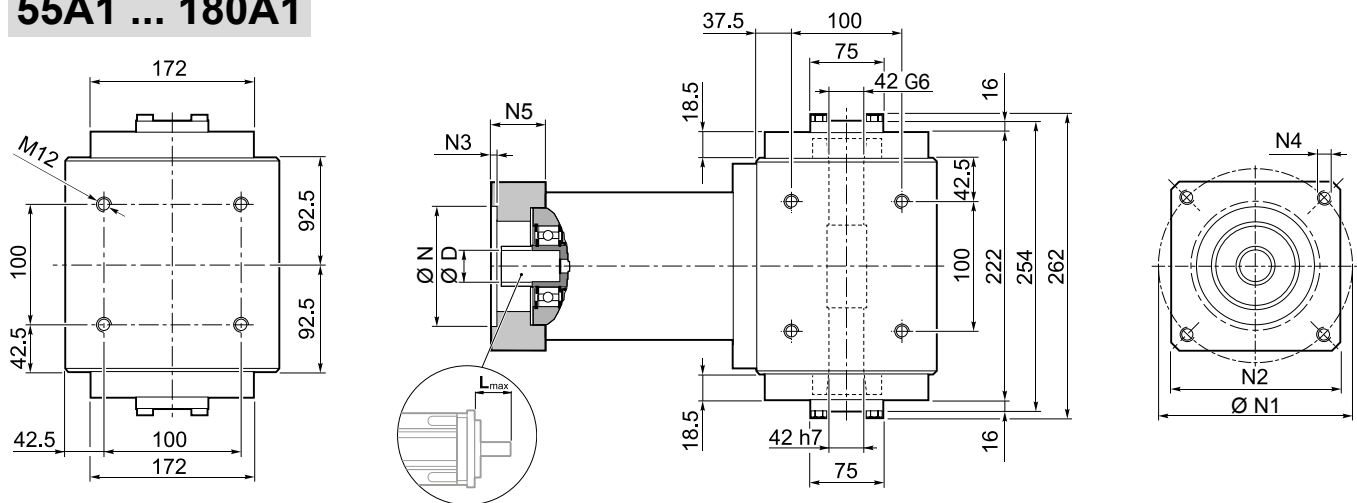

TR

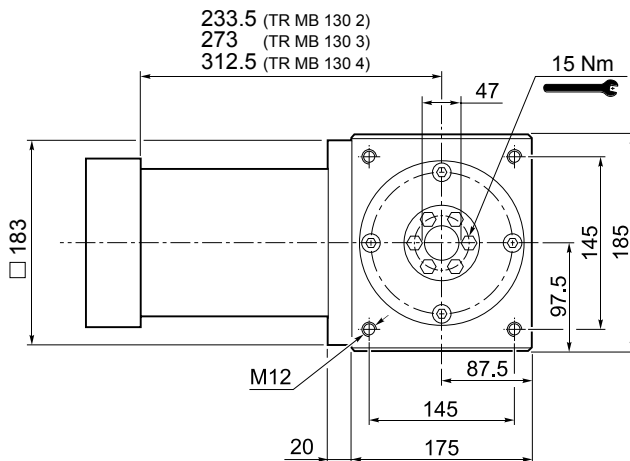

TR MB 130 2	54
TR MB 130 3	58
TR MB 130 4	61

											N	N1	N2	N3	N4	N5	L _{max}
	D																
55A1	14	15.875	16	19	-	-	-	-	-	-	55.5	125.7	130	4	M6x15	39.5	50
80A2	14	15.875	16	19	-	-	-	-	-	-	80	100	130	4	M6x15	39.5	50
95A1	14	15.875	16	19	22	24	-	-	-	-	95	115	130	4	M8x20	39.5	50
110A1	14	15.875	16	19	22	24	-	-	-	-	110	130	130	4	M8x20	39.5	50
110B1	14	15.875	16	19	22	24	-	-	-	-	110	145	130	6.5	M8x20	49.5	60
114A0	14	15.875	16	19	22	24	-	-	-	-	114.3	200	170	5.5	M12x25	39.5	50
114A	14	15.875	16	19	22	24	28	32	35	38	114.3	200	170	5.5	M12x25	69.5	80
130A	14	15.875	16	19	22	24	-	-	-	-	130	165	140	4	M10x20	39.5	50
130A1	14	15.875	16	19	22	24	28	32	-	-	130	165	140	4	M10x20	49.5	60
180A	14	15.875	16	19	22	24	28	32	-	-	180	215	190	5.5	M14x25	49.5	60
180A1	14	15.875	16	19	22	24	28	32	35	38	180	215	190	5.5	M14x25	69.5	80

Please contact us for other motor adapters and input shaft bore.

TR MB 130

FM

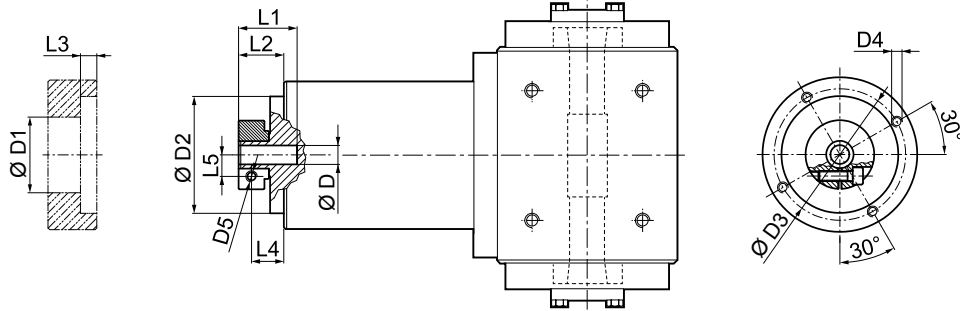

D		D1	D2	D3	D4	D5	L1	L2	L3	L4	L5	
14	15.875	16	48	113	125.5	M8x15	M6	40	27.5	6	20	14.5
19			51	113	125.5	M8x15	M6	40	27.5	6	20	16.5
22	24		56.5	113	125.5	M8x15	M6	41	28.5	6	19.5	19
28			67	113	125.5	M8x15	M8	41	28.5	6	19.5	22.5
32			71	113	125.5	M8x15	M8	41	28.5	6	19.5	24.5
35			73	113	125.5	M8x15	M8	50	37.5	11.25	26	26
38			77.5	113	125.5	M8x15	M8	50	37.5	11.25	26	28

i	M _{n2} [Nm]	M _{a2} [Nm]	M _{p2} [Nm]	n ₁ [min ⁻¹]	n _{1 max} [min ⁻¹]	Ψ _S [arcmin]	Ψ _R [arcmin]	C _t [Nm/arcmin]	η %	J _G [kgcm ²]			
										D	14 ... 19	22 - 24	28 - 32
TR MB 130 2_3	215	400	800	2100	3000	5'	3'	45.0	94	5.25	5.46	5.81	7.16
TR MB 130 2_4	380	600	1100	2400	3500	5'	3'	45.0	94	3.06	3.26	3.61	4.97
TR MB 130 2_5	380	600	1100	2900	3500	5'	3'	45.0	94	2.22	2.42	2.77	4.13
TR MB 130 2_6	380	600	1100	2900	3500	5'	3'	45.0	94	1.19	1.40	1.75	3.10
TR MB 130 2_7	380	600	1100	3200	4000	5'	3'	45.0	94	1.47	1.68	2.03	3.38
TR MB 130 2_10	215	400	800	3200	4000	5'	3'	45.0	94	1.04	1.25	1.60	2.95
TR MB 130 3_9	215	400	800	2100	3000	5'	3'	38.5	91	4.82	5.02	5.37	6.72
TR MB 130 3_12	450	700	1300	2100	3000	5'	3'	38.5	91	4.57	4.78	5.13	6.48
TR MB 130 3_15	450	700	1300	2100	3000	5'	3'	38.5	91	4.48	4.69	5.04	6.39
TR MB 130 3_16	450	700	1300	2400	3500	5'	3'	38.5	91	2.67	2.88	3.23	4.58
TR MB 130 3_20	450	700	1300	2900	3500	5'	3'	38.5	91	1.97	2.18	2.53	3.88
TR MB 130 3_25	450	700	1300	2900	3500	5'	3'	38.5	91	1.94	2.15	2.50	3.85
TR MB 130 3_28	450	700	1300	3200	4000	5'	3'	38.5	91	1.34	1.55	1.90	3.25
TR MB 130 3_30	215	400	800	3200	4000	5'	3'	38.5	91	1.00	1.21	1.56	2.91
TR MB 130 3_35	450	700	1300	3200	4000	5'	3'	38.5	91	1.33	1.53	1.88	3.24
TR MB 130 3_36	380	600	1100	2900	3500	5'	3'	38.5	91	1.05	1.26	1.61	2.96
TR MB 130 3_40	450	700	1300	3200	4000	5'	3'	38.5	91	0.98	1.19	1.54	2.89
TR MB 130 3_50	450	700	1300	3200	4000	5'	3'	38.5	91	0.97	1.18	1.53	2.88
TR MB 130 3_70	450	700	1300	3200	4000	5'	3'	38.5	91	0.96	1.17	1.52	2.87
TR MB 130 3_100	215	400	800	3200	4000	5'	3'	38.5	91	0.96	1.17	1.52	2.87
TR MB 130 4_48	450	700	1300	2400	3500	7'	5'	30.0	89	2.77	2.98	3.33	4.68
TR MB 130 4_64	450	700	1300	2400	3500	7'	5'	30.0	89	2.65	2.86	3.21	4.56
TR MB 130 4_75	450	700	1300	2900	3500	7'	5'	30.0	89	2.03	2.24	2.59	3.94
TR MB 130 4_80	450	700	1300	2400	3500	7'	5'	30.0	89	2.65	2.85	3.20	4.56
TR MB 130 4_84	450	700	1300	3200	4000	7'	5'	30.0	89	1.37	1.58	1.93	3.28
TR MB 130 4_90	215	400	800	3200	4000	7'	5'	30.0	89	1.00	1.20	1.55	2.91
TR MB 130 4_120	450	700	1300	3200	4000	7'	5'	30.0	89	0.99	1.20	1.55	2.90
TR MB 130 4_125	450	700	1300	2900	3500	7'	5'	30.0	89	1.93	2.13	2.48	3.84
TR MB 130 4_140	450	700	1300	3200	4000	7'	5'	30.0	89	1.34	1.54	1.89	3.25
TR MB 130 4_150	450	700	1300	3200	4000	7'	5'	30.0	89	0.99	1.20	1.55	2.90
TR MB 130 4_160	450	700	1300	3200	4000	7'	5'	30.0	89	0.98	1.18	1.53	2.89
TR MB 130 4_175	450	700	1300	3200	4000	7'	5'	30.0	89	1.32	1.53	1.88	3.23
TR MB 130 4_200	450	700	1300	3200	4000	7'	5'	30.0	89	0.97	1.18	1.53	2.88
TR MB 130 4_210	450	700	1300	3200	4000	7'	5'	30.0	89	0.99	1.20	1.55	2.90
TR MB 130 4_216	450	700	1300	2900	3500	7'	5'	30.0	89	1.05	1.26	1.61	2.96
TR MB 130 4_250	450	700	1300	3200	4000	7'	5'	30.0	89	0.97	1.18	1.53	2.88
TR MB 130 4_280	450	700	1300	3200	4000	7'	5'	30.0	89	0.96	1.17	1.52	2.87
TR MB 130 4_350	450	700	1300	3200	4000	7'	5'	30.0	89	0.96	1.17	1.52	2.87
TR MB 130 4_400	450	700	1300	3200	4000	7'	5'	30.0	89	0.96	1.17	1.52	2.87
TR MB 130 4_500	450	700	1300	3200	4000	7'	5'	30.0	89	0.96	1.17	1.52	2.87
TR MB 130 4_700	450	700	1300	3200	4000	7'	5'	30.0	89	0.96	1.17	1.52	2.87
TR MB 130 4_1000	215	400	800	3200	4000	7'	5'	30.0	89	0.96	1.17	1.52	2.87

TR 160

IS

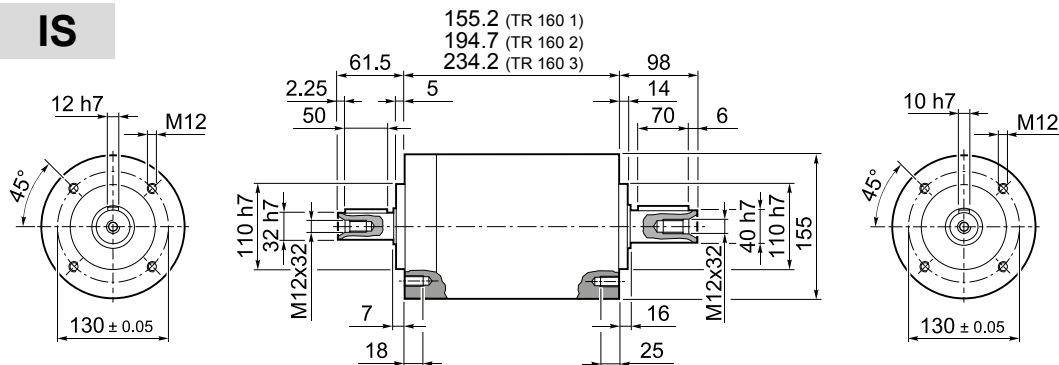

TR 160 1	17.0
TR 160 2	21
TR 160 3	28

TR

55A1 ... 180A1

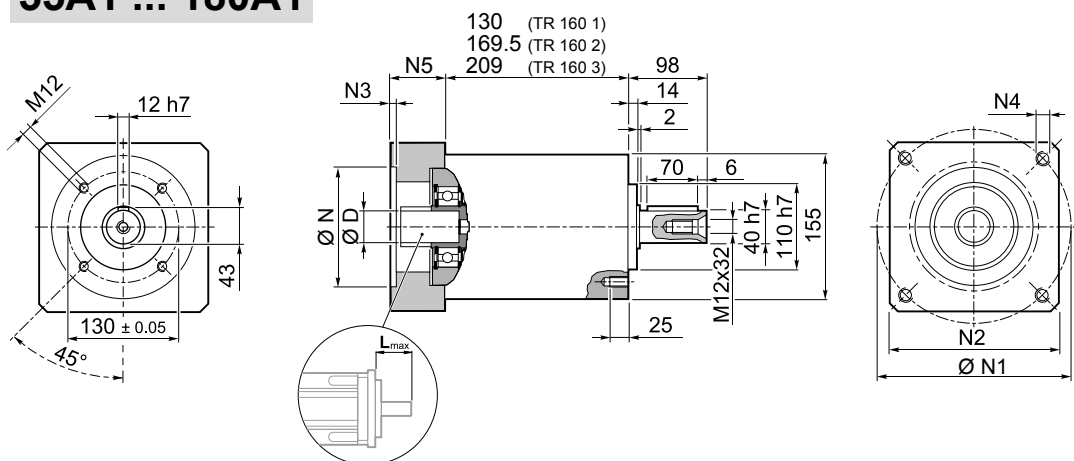

TR 160 1	17.0
TR 160 2	21
TR 160 3	28

											N	N1	N2	N3	N4	N5	L _{max}
55A1	14	15.875	16	19	-	-	-	-	-	-	55.5	125.7	140	5	M6x15	39.5	50
80A2	14	15.875	16	19	-	-	-	-	-	-	80	100	140	5	M6x15	39.5	50
95A1	14	15.875	16	19	22	24	-	-	-	-	95	115	140	5	M8x20	39.5	50
110A1	14	15.875	16	19	22	24	-	-	-	-	110	130	140	5	M8x20	39.5	50
110B1	14	15.875	16	19	22	24	-	-	-	-	110	145	140	6.5	M8x20	49.5	60
114A	14	15.875	16	19	22	24	28	32	35	38	114.3	200	170	6.5	M12x25	69.5	80
130A	14	15.875	16	19	22	24	-	-	-	-	130	165	140	5	M10x20	39.5	50
130A1	14	15.875	16	19	22	24	28	32	-	-	130	165	140	5	M10x20	49.5	60
180A	14	15.875	16	19	22	24	28	32	-	-	180	215	190	6.5	M14x25	49.5	60
180A1	14	15.875	16	19	22	24	28	32	35	38	180	215	190	6.5	M14x25	69.5	80

Please contact us for other motor adapters and input shaft bore.

TR 160

FM

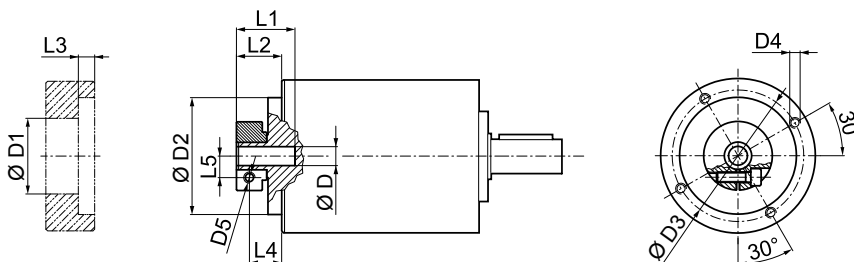

D	D1	D2	D3	D4	D5	L1	L2	L3	L4	L5
14	48	130	142.5	M8x16	M6	40	27.5	6	20	14.5
19	51	130	142.5	M8x16	M6	40	27.5	6	20	16.5
22	56.5	130	142.5	M8x16	M6	41	28.5	6	19.5	19
28	67	130	142.5	M8x16	M8	41	28.5	6	19.5	22.5
32	71	130	142.5	M8x16	M8	41	28.5	6	19.5	24.5
35	73	130	142.5	M8x16	M8	50	37.5	11.25	26	26
38	77.5	130	142.5	M8x16	M8	50	37.5	11.25	26	28

i	M _{n2} [Nm]	M _{a2} [Nm]	M _{p2} [Nm]	n ₁ [min ⁻¹]	n _{1 max} [min ⁻¹]	φ _s [arcmin]	φ _R [arcmin]	C _t [Nm/arcmin]	R _{1 max} [N]	R _{2 max} [N]	A _{2 max} [N]	η [%]	J _G [kgcm ²]			
													14 ... 19	22 - 24	28 - 32	35 - 38
TR 160 1_3	350	660	1200	1900	3000	5'	3'	90	1200	6500	7500	97	8.39	8.60	8.95	10.30
TR 160 1_4	500	750	1400	2200	3500	5'	3'	90	1200	6500	7500	97	4.68	4.89	5.24	6.59
TR 160 1_5	500	750	1400	2500	3500	5'	3'	90	1200	6500	7500	97	3.28	3.49	3.84	5.19
TR 160 1_6	500	750	1400	2500	3500	5'	3'	90	1200	6500	7500	97	1.32	1.53	1.88	3.23
TR 160 1_7	500	750	1400	3000	4000	5'	3'	90	1200	6500	7500	97	2.03	2.24	2.59	3.94
TR 160 1_10	350	660	1200	3000	4000	5'	3'	90	1200	6500	7500	97	1.33	1.53	1.88	3.24
TR 160 2_9	350	660	1200	1900	3000	5'	3'	83.5	1200	6500	7500	94	7.51	7.72	8.07	9.42
TR 160 2_12	700	950	1800	1900	3000	5'	3'	83.5	1200	6500	7500	94	7.10	7.30	7.65	9.01
TR 160 2_15	700	950	1800	1900	3000	5'	3'	83.5	1200	6500	7500	94	6.94	7.15	7.50	8.85
TR 160 2_16	700	950	1800	2200	3500	5'	3'	83.5	1200	6500	7500	94	3.95	4.16	4.51	5.86
TR 160 2_20	700	950	1800	2500	3500	5'	3'	83.5	1200	6500	7500	94	2.82	3.02	3.37	4.73
TR 160 2_25	700	950	1800	2500	3500	5'	3'	83.5	1200	6500	7500	94	2.76	2.97	3.32	4.67
TR 160 2_28	700	950	1800	3000	4000	5'	3'	83.5	1200	6500	7500	94	1.79	2.00	2.35	3.70
TR 160 2_30	350	660	1200	3000	4000	5'	3'	83.5	1200	6500	7500	94	1.25	1.46	1.81	3.16
TR 160 2_35	700	950	1800	3000	4000	5'	3'	83.5	1200	6500	7500	94	1.77	1.97	2.32	3.68
TR 160 2_36	500	750	1400	2500	3500	5'	3'	83.5	1200	6500	7500	94	1.06	1.27	1.62	2.97
TR 160 2_40	700	950	1800	3000	4000	5'	3'	83.5	1200	6500	7500	94	1.21	1.42	1.77	3.12
TR 160 2_50	700	950	1800	3000	4000	5'	3'	83.5	1200	6500	7500	94	1.20	1.40	1.75	3.11
TR 160 2_70	700	950	1800	3000	4000	5'	3'	83.5	1200	6500	7500	94	1.18	1.39	1.74	3.09
TR 160 2_100	350	660	1200	3000	4000	5'	3'	83.5	1200	6500	7500	94	1.18	1.38	1.73	3.09
TR 160 3_48	700	950	1800	2200	3500	7'	5'	60	1200	6500	7500	91	4.10	4.31	4.66	6.01
TR 160 3_64	700	950	1800	2200	3500	7'	5'	60	1200	6500	7500	91	3.90	4.11	4.46	5.81
TR 160 3_75	700	950	1800	2500	3500	7'	5'	60	1200	6500	7500	91	2.91	3.11	3.46	4.82
TR 160 3_80	700	950	1800	2200	3500	7'	5'	60	1200	6500	7500	91	3.90	4.11	4.46	5.81
TR 160 3_84	700	950	1800	3000	4000	7'	5'	60	1200	6500	7500	91	1.84	2.05	2.40	3.75
TR 160 3_90	350	660	1200	3000	4000	7'	5'	60	1200	6500	7500	91	1.24	1.45	1.80	3.15
TR 160 3_120	700	950	1800	3000	4000	7'	5'	60	1200	6500	7500	91	1.23	1.44	1.79	3.14
TR 160 3_125	700	950	1800	2500	3500	7'	5'	60	1200	6500	7500	91	2.74	2.95	3.30	4.65
TR 160 3_140	700	950	1800	3000	4000	7'	5'	60	1200	6500	7500	91	1.78	1.98	2.33	3.69
TR 160 3_150	700	950	1800	3000	4000	7'	5'	60	1200	6500	7500	91	1.23	1.44	1.79	3.14
TR 160 3_160	700	950	1800	3000	4000	7'	5'	60	1200	6500	7500	91	1.20	1.41	1.76	3.11
TR 160 3_175	700	950	1800	3000	4000	7'	5'	60	1200	6500	7500	91	1.76	1.96	2.31	3.67
TR 160 3_200	700	950	1800	3000	4000	7'	5'	60	1200	6500	7500	91	1.20	1.41	1.76	3.11
TR 160 3_210	700	950	1800	3000	4000	7'	5'	60	1200	6500	7500	91	1.23	1.44	1.79	3.14
TR 160 3_250	700	950	1800	3000	4000	7'	5'	60	1200	6500	7500	91	1.19	1.40	1.75	3.10
TR 160 3_280	700	950	1800	3000	4000	7'	5'	60	1200	6500	7500	91	1.18	1.39	1.74	3.09
TR 160 3_350	700	950	1800	3000	4000	7'	5'	60	1200	6500	7500	91	1.18	1.39	1.74	3.09
TR 160 3_400	700	950	1800	3000	4000	7'	5'	60	1200	6500	7500	91	1.18	1.38	1.73	3.09
TR 160 3_500	700	950	1800	3000	4000	7'	5'	60	1200	6500	7500	91	1.18	1.38	1.73	3.09
TR 160 3_700	700	950	1800	3000	4000	7'	5'	60	1200	6500	7500	91	1.18	1.38	1.73	3.09
TR 160 3_1000	350	660	1200	3000	4000	7'	5'	60	1200	6500	7500	91	1.18	1.38	1.73	3.09

S-M-BOR-NL-CAFS-001-V01

TR

TR G 160

55A1 ... 180A1

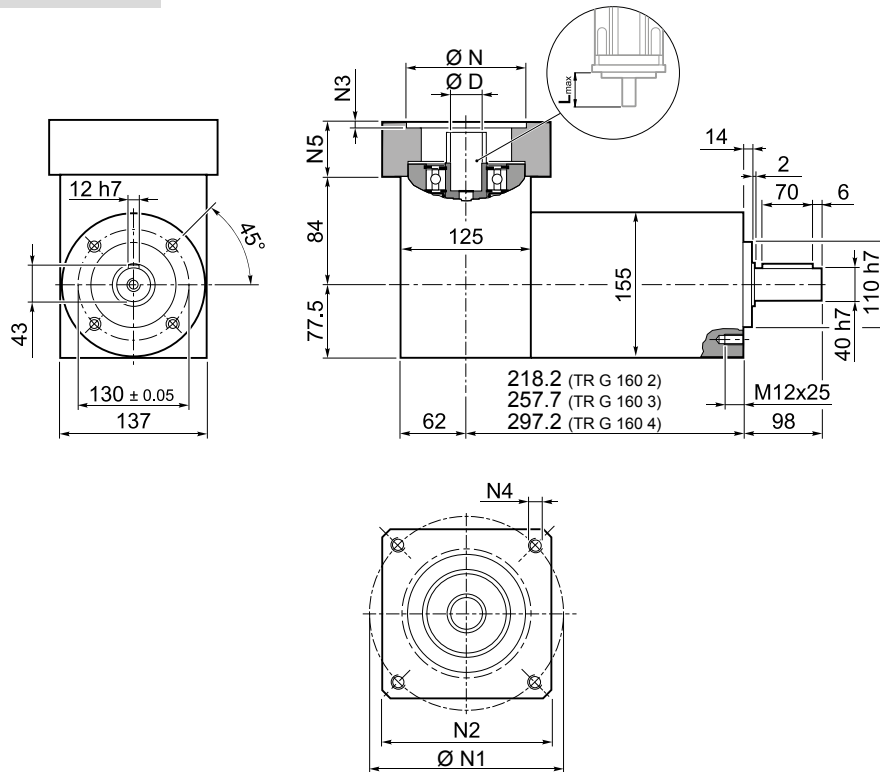

TR G 160 2	24
TR G 160 3	28
TR G 160 4	34

TR

											N	N1	N2	N3	N4	N5	L _{max}
55A1	14	15.875	16	19	-	-	-	-	-	-	55.5	125.7	140	5	M6x15	39.5	50
80A2	14	15.875	16	19	-	-	-	-	-	-	80	100	140	5	M6x15	39.5	50
95A1	14	15.875	16	19	22	24	-	-	-	-	95	115	140	5	M8x20	39.5	50
110A1	14	15.875	16	19	22	24	-	-	-	-	110	130	140	5	M8x20	39.5	50
110B1	14	15.875	16	19	22	24	-	-	-	-	110	145	140	6.5	M8x20	49.5	60
114A	14	15.875	16	19	22	24	28	32	35	38	114.3	200	170	6.5	M12x25	69.5	80
130A	14	15.875	16	19	22	24	-	-	-	-	130	165	140	5	M10x20	39.5	50
130A1	14	15.875	16	19	22	24	28	32	-	-	130	165	140	5	M10x20	49.5	60
180A	14	15.875	16	19	22	24	28	32	-	-	180	215	190	6.5	M14x25	49.5	60
180A1	14	15.875	16	19	22	24	28	32	35	38	180	215	190	6.5	M14x25	69.5	80

Please contact us for other motor adapters and input shaft bore.

TR G 160

FM

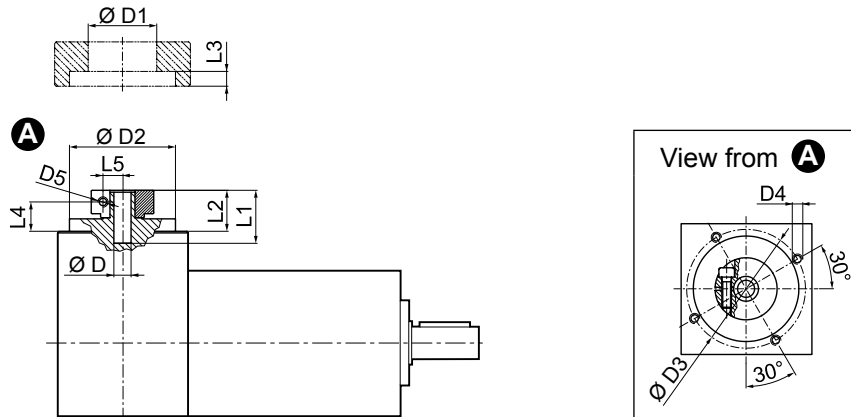

D		D1	D2	D3	D4	D5	L1	L2	L3	L4	L5	
14	15.875	16	48	113	125.5	M8x15	M6	40	27.5	6	20	14.5
19			51	113	125.5	M8x15	M6	40	27.5	6	20	16.5
22	24		56.5	113	125.5	M8x15	M6	41	28.5	6	19.5	19
28			67	113	125.5	M8x15	M8	41	28.5	6	19.5	22.5
32			71	113	125.5	M8x15	M8	41	28.5	6	19.5	24.5
35			73	113	125.5	M8x15	M8	50	37.5	11.25	26	26
38			77.5	113	125.5	M8x15	M8	50	37.5	11.25	26	28

i	M _{n2} [Nm]	M _{a2} [Nm]	M _{p2} [Nm]	n ₁ [min ⁻¹]	n _{1 max} [min ⁻¹]	φ _s [arcmin]	φ _R [arcmin]	C _t [Nm/arcmin]	R _{2 max} [N]	A _{2 max} [N]	η %	J _G [kgcm ²]			
												14 ... 19	22 - 24	28 - 32	35 - 38
TR G 160 2_3	350	660	1200	1900	3000	5'	3'	90	6500	7500	94	10.23	10.42	10.80	13.51
TR G 160 2_4	500	750	1400	2200	3500	5'	3'	90	6500	7500	94	6.52	6.71	7.09	9.80
TR G 160 2_5	500	750	1400	2500	3500	5'	3'	90	6500	7500	94	5.87	6.06	6.45	9.16
TR G 160 2_6	500	750	1400	2500	3500	5'	3'	90	6500	7500	94	4.58	4.77	5.16	7.86
TR G 160 2_7	500	750	1400	3000	4000	5'	3'	90	6500	7500	94	5.29	5.48	5.87	8.57
TR G 160 2_10	350	660	1200	3000	4000	5'	3'	90	6500	7500	94	4.97	5.16	5.54	8.25
TR G 160 3_9	350	660	1200	1900	3000	5'	3'	83.5	6500	7500	91	9.35	9.54	9.92	12.63
TR G 160 3_12	700	950	1800	1900	3000	5'	3'	83.5	6500	7500	91	8.78	8.97	9.36	12.07
TR G 160 3_15	700	950	1800	1900	3000	5'	3'	83.5	6500	7500	91	8.71	8.90	9.29	11.99
TR G 160 3_16	700	950	1800	2200	3500	5'	3'	83.5	6500	7500	91	5.79	5.98	6.36	9.07
TR G 160 3_20	700	950	1800	2500	3500	5'	3'	83.5	6500	7500	91	5.41	6.20	6.59	9.30
TR G 160 3_25	700	950	1800	2500	3500	5'	3'	83.5	6500	7500	91	5.95	5.54	5.93	8.64
TR G 160 3_28	700	950	1800	3000	4000	5'	3'	83.5	6500	7500	91	5.05	5.24	5.63	8.33
TR G 160 3_30	350	660	1200	3000	4000	5'	3'	83.5	6500	7500	91	4.89	5.09	5.47	8.18
TR G 160 3_35	700	950	1800	3000	4000	5'	3'	83.5	6500	7500	91	5.36	5.54	5.93	8.64
TR G 160 3_36	500	750	1400	2500	3500	5'	3'	83.5	6500	7500	91	4.32	4.51	4.90	7.60
TR G 160 3_40	700	950	1800	3000	4000	5'	3'	83.5	6500	7500	91	5.00	5.19	5.58	8.28
TR G 160 3_50	700	950	1800	3000	4000	5'	3'	83.5	6500	7500	91	4.99	5.18	5.56	8.27
TR G 160 3_70	700	950	1800	3000	4000	5'	3'	83.5	6500	7500	91	4.82	5.02	5.40	8.11
TR G 160 3_100	350	660	1200	3000	4000	5'	3'	83.5	6500	7500	91	4.82	5.01	5.39	8.10
TR G 160 4_48	700	950	1800	2200	3500	7'	5'	60	6500	7500	89	5.94	6.13	6.53	9.22
TR G 160 4_64	700	950	1800	2200	3500	7'	5'	60	6500	7500	89	5.74	5.93	6.31	9.02
TR G 160 4_75	700	950	1800	2500	3500	7'	5'	60	6500	7500	89	5.50	5.68	6.07	8.79
TR G 160 4_80	700	950	1800	2200	3500	7'	5'	60	6500	7500	89	5.74	5.93	6.31	9.02
TR G 160 4_84	700	950	1800	3000	4000	7'	5'	60	6500	7500	89	5.10	5.29	5.68	8.38
TR G 160 4_90	350	660	1200	3000	4000	7'	5'	60	6500	7500	89	4.88	5.08	5.46	8.17
TR G 160 4_120	700	950	1800	3000	4000	7'	5'	60	6500	7500	89	4.87	5.07	5.45	8.16
TR G 160 4_125	700	950	1800	2500	3500	7'	5'	60	6500	7500	89	5.33	5.52	5.91	8.62
TR G 160 4_140	700	950	1800	3000	4000	7'	5'	60	6500	7500	89	5.04	5.22	5.61	8.32
TR G 160 4_150	700	950	1800	3000	4000	7'	5'	60	6500	7500	89	4.87	5.07	5.45	8.16
TR G 160 4_160	700	950	1800	3000	4000	7'	5'	60	6500	7500	89	4.84	5.04	5.42	8.13
TR G 160 4_175	700	950	1800	3000	4000	7'	5'	60	6500	7500	89	5.02	5.20	5.59	8.30
TR G 160 4_200	700	950	1800	3000	4000	7'	5'	60	6500	7500	89	4.84	5.04	5.42	8.13
TR G 160 4_210	700	950	1800	3000	4000	7'	5'	60	6500	7500	89	4.87	5.07	5.45	8.16
TR G 160 4_250	700	950	1800	3000	4000	7'	5'	60	6500	7500	89	4.83	5.03	5.41	8.12
TR G 160 4_280	700	950	1800	3000	4000	7'	5'	60	6500	7500	89	4.82	5.02	5.40	8.11
TR G 160 4_350	700	950	1800	3000	4000	7'	5'	60	6500	7500	89	4.82	2.05	5.40	8.11
TR G 160 4_400	700	950	1800	3000	4000	7'	5'	60	6500	7500	89	4.82	5.01	5.39	8.11
TR G 160 4_500	700	950	1800	3000	4000	7'	5'	60	6500	7500	89	4.82	5.01	5.39	8.11
TR G 160 4_700	700	950	1800	3000	4000	7'	5'	60	6500	7500	89	4.82	5.01	5.39	8.11
TR G 160 4_1000	350	660	1200	3000	4000	7'	5'	60	6500	7500	89	4.82	5.01	5.39	8.11

S-M-BOR-NL-CAFS-001-V01

TR

TR MB 160

55A1 ... 180A1

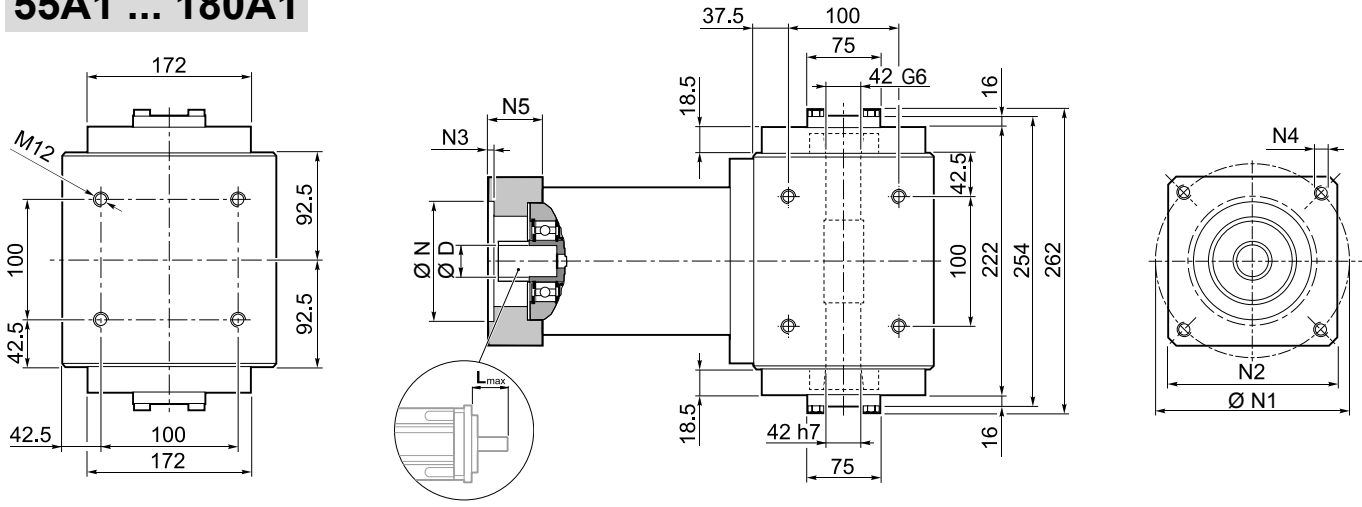

TR

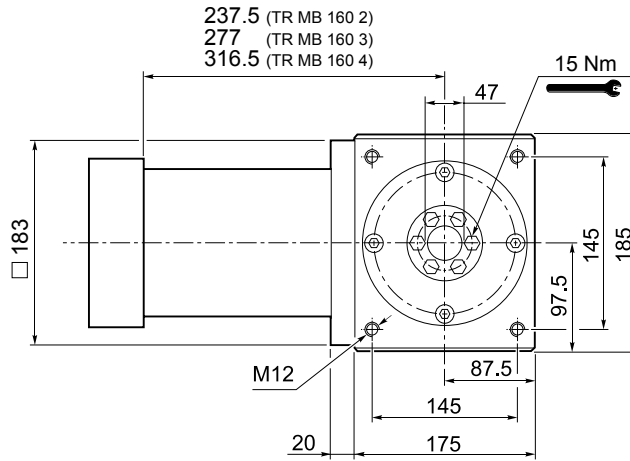

TR MB 160 2	59
TR MB 160 3	63.5
TR MB 160 4	70.5

											N	N1	N2	N3	N4	N5	L _{max}
	D																
55A1	14	15.875	16	19	-	-	-	-	-	-	55.5	125.7	140	5	M6x15	39.5	50
80A2	14	15.875	16	19	-	-	-	-	-	-	80	100	140	5	M6x15	39.5	50
95A1	14	15.875	16	19	22	24	-	-	-	-	95	115	140	5	M8x20	39.5	50
110A1	14	15.875	16	19	22	24	-	-	-	-	110	130	140	5	M8x20	39.5	50
110B1	14	15.875	16	19	22	24	-	-	-	-	110	145	140	6.5	M8x20	49.5	60
114A	14	15.875	16	19	22	24	28	32	35	38	114.3	200	170	6.5	M12x25	69.5	80
130A	14	15.875	16	19	22	24	-	-	-	-	130	165	140	5	M10x20	39.5	50
130A1	14	15.875	16	19	22	24	28	32	-	-	130	165	140	5	M10x20	49.5	60
180A	14	15.875	16	19	22	24	28	32	-	-	180	215	190	6.5	M14x25	49.5	60
180A1	14	15.875	16	19	22	24	28	32	35	38	180	215	190	6.5	M14x25	69.5	80

Please contact us for other motor adapters and input shaft bore.

TR MB 160

FM

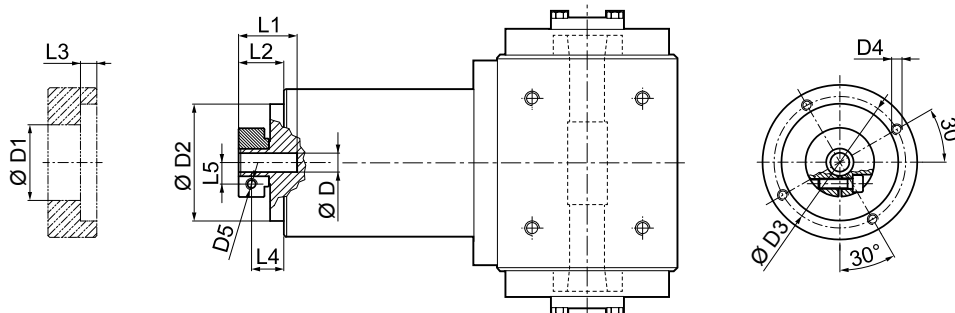

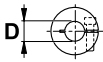
	D1	D2	D3	D4	D5	L1	L2	L3	L4	L5
14 15.875 16	48	130	142.5	M8x16	M6	40	27.5	6	20	14.5
19	51	130	142.5	M8x16	M6	40	27.5	6	20	16.5
22 24	56.5	130	142.5	M8x16	M6	41	28.5	6	19.5	19
28	67	130	142.5	M8x16	M8	41	28.5	6	19.5	22.5
32	71	130	142.5	M8x16	M8	41	28.5	6	19.5	24.5
35	73	130	142.5	M8x16	M8	50	37.5	11.25	26	26
38	77.5	130	142.5	M8x16	M8	50	37.5	11.25	26	28

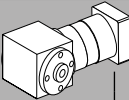
	i	M _{n2} [Nm]	M _{a2} [Nm]	M _{p2} [Nm]	n ₁ [min ⁻¹]	n _{1 max} [min ⁻¹]	ψ _S [arcmin]	ψ _R [arcmin]	C _t [Nm/arcmin]	η %	J _G [kgcm ²]			
											14 ... 19	22 - 24	28 - 32	35 - 38
TR MB 160 2_3		350	660	1200	1900	3000	5'	3'	90	94	8.39	8.60	8.95	10.30
TR MB 160 2_4		500	750	1400	2200	3500	5'	3'	90	94	4.68	4.89	5.24	6.59
TR MB 160 2_5		500	750	1400	2500	3500	5'	3'	90	94	3.28	3.49	3.84	5.19
TR MB 160 2_6		500	750	1400	2500	3500	5'	3'	90	94	1.32	1.53	1.88	3.23
TR MB 160 2_7		500	750	1400	3000	4000	5'	3'	90	94	2.03	2.24	2.59	3.94
TR MB 160 2_10		350	660	1200	3000	4000	5'	3'	90	94	1.33	1.53	1.88	3.24
TR MB 160 3_9		350	660	1200	1900	3000	5'	3'	83	91	7.51	7.72	8.07	9.42
TR MB 160 3_12		700	950	1800	1900	3000	5'	3'	83	91	7.10	7.30	7.65	9.01
TR MB 160 3_15		700	950	1800	1900	3000	5'	3'	83	91	6.94	7.15	7.50	8.85
TR MB 160 3_16		700	950	1800	2200	3500	5'	3'	83	91	3.95	4.16	4.51	5.86
TR MB 160 3_20		700	950	1800	2500	3500	5'	3'	83	91	2.82	3.02	3.37	4.73
TR MB 160 3_25		700	950	1800	2500	3500	5'	3'	83	91	2.76	2.97	3.32	4.67
TR MB 160 3_28		700	950	1800	3000	4000	5'	3'	83	91	1.79	2.00	2.35	3.70
TR MB 160 3_30		350	660	1200	3000	4000	5'	3'	83	91	1.25	1.46	1.81	3.16
TR MB 160 3_35		700	950	1800	3000	4000	5'	3'	83	91	1.77	1.97	2.32	3.68
TR MB 160 3_36		500	750	1400	2500	3500	5'	3'	83	91	1.06	1.27	1.62	2.97
TR MB 160 3_40		700	950	1800	3000	4000	5'	3'	83	91	1.21	1.42	1.77	3.12
TR MB 160 3_50		700	950	1800	3000	4000	5'	3'	83	91	1.20	1.40	1.75	3.11
TR MB 160 3_70		700	950	1800	3000	4000	5'	3'	83	91	1.18	1.39	1.74	3.09
TR MB 160 3_100		350	660	1200	3000	4000	5'	3'	83	91	1.18	1.38	1.73	3.09
TR MB 160 4_48		700	950	1800	2200	3500	7'	5'	60	89	4.10	4.31	4.66	6.01
TR MB 160 4_64		700	950	1800	2200	3500	7'	5'	60	89	3.90	4.11	4.46	5.81
TR MB 160 4_75		700	950	1800	2500	3500	7'	5'	60	89	2.91	3.11	3.46	4.82
TR MB 160 4_80		700	950	1800	2200	3500	7'	5'	60	89	3.90	4.11	4.46	5.81
TR MB 160 4_84		700	950	1800	3000	4000	7'	5'	60	89	1.84	2.05	2.40	3.75
TR MB 160 4_90		350	660	1200	3000	4000	7'	5'	60	89	1.24	1.45	1.80	3.15
TR MB 160 4_120		700	950	1800	3000	4000	7'	5'	60	89	1.23	1.44	1.79	3.14
TR MB 160 4_125		700	950	1800	2500	3500	7'	5'	60	89	2.74	2.95	3.30	4.65
TR MB 160 4_140		700	950	1800	3000	4000	7'	5'	60	89	1.78	1.98	2.33	3.69
TR MB 160 4_150		700	950	1800	3000	4000	7'	5'	60	89	1.23	1.44	1.79	3.14
TR MB 160 4_160		700	950	1800	3000	4000	7'	5'	60	89	1.20	1.41	1.76	3.11
TR MB 160 4_175		700	950	1800	3000	4000	7'	5'	60	89	1.76	1.96	2.31	3.67
TR MB 160 4_200		700	950	1800	3000	4000	7'	5'	60	89	1.20	1.41	1.76	3.11
TR MB 160 4_210		700	950	1800	3000	4000	7'	5'	60	89	1.23	1.44	1.79	3.14
TR MB 160 4_250		700	950	1800	3000	4000	7'	5'	60	89	1.19	1.40	1.75	3.10
TR MB 160 4_280		700	950	1800	3000	4000	7'	5'	60	89	1.18	1.39	1.74	3.09
TR MB 160 4_350		700	950	1800	3000	4000	7'	5'	60	89	1.18	1.39	1.74	3.09
TR MB 160 4_400		700	950	1800	3000	4000	7'	5'	60	89	1.18	1.38	1.73	3.09
TR MB 160 4_500		700	950	1800	3000	4000	7'	5'	60	89	1.18	1.38	1.73	3.09
TR MB 160 4_700		700	950	1800	3000	4000	7'	5'	60	89	1.18	1.38	1.73	3.09
TR MB 160 4_1000		350	660	1200	3000	4000	7'	5'	60	89	1.18	1.38	1.73	3.09

TR

TR 190

55A1 ... 180A1

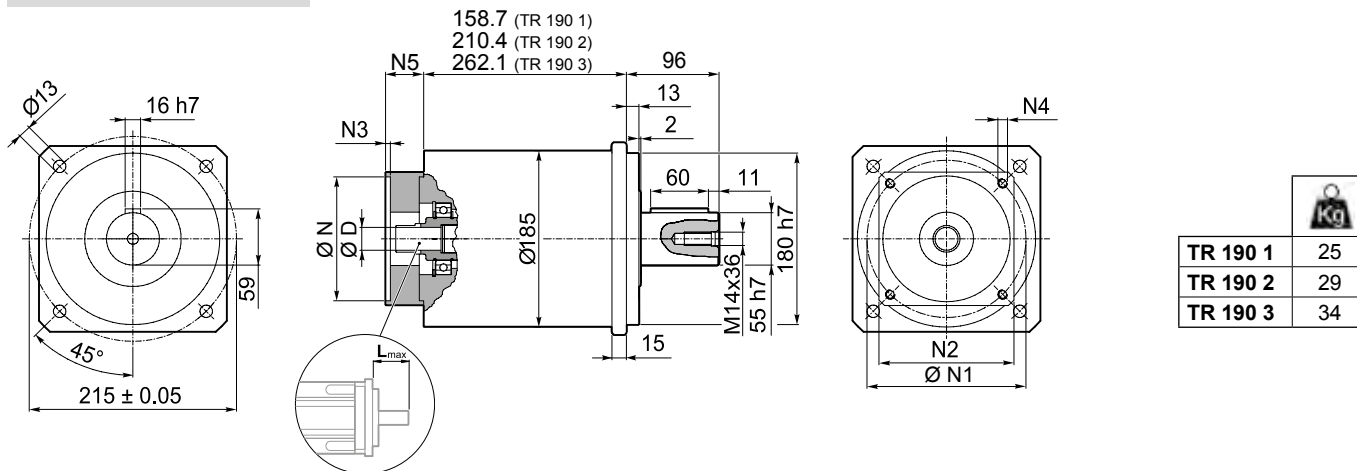

TR

	D												N	N1	N2	N3	N4	N5	L _{max}	
55A1	14	16	19	-	-	-	-	-	-	-	-	-	-	55.5	125.7	140	5	M6x15	39.5	50
80A2	14	16	19	-	-	-	-	-	-	-	-	-	-	80	100	140	5	M6x15	39.5	50
95A1	14	16	19	22	24	-	-	-	-	-	-	-	-	95	115	140	5	M8x20	39.5	50
110A1	14	16	19	22	24	-	-	-	-	-	-	-	-	110	130	140	5	M8x20	39.5	50
110B1	14	16	19	22	24	-	-	-	-	-	-	-	-	110	145	140	6.5	M8x20	49.5	60
114A	14	16	19	22	24	28	32	35	38	42	45	48	114.3	200	170	6.5	M12x25	69.5	80	
130A	14	16	19	22	24	-	-	-	-	-	-	-	130	165	140	5	M10x20	39.5	50	
130A1	14	16	19	22	24	28	32	-	-	-	-	-	130	165	140	5	M10x20	49.5	60	
180A	14	16	19	22	24	28	32	-	-	-	-	-	180	215	190	6.5	M14x25	49.5	60	
180A1	14	16	19	22	24	28	32	35	38	42	45	48	180	215	190	6.5	M14x25	69.5	80	

Please contact us for other motor adapters and input shaft bore.

FM

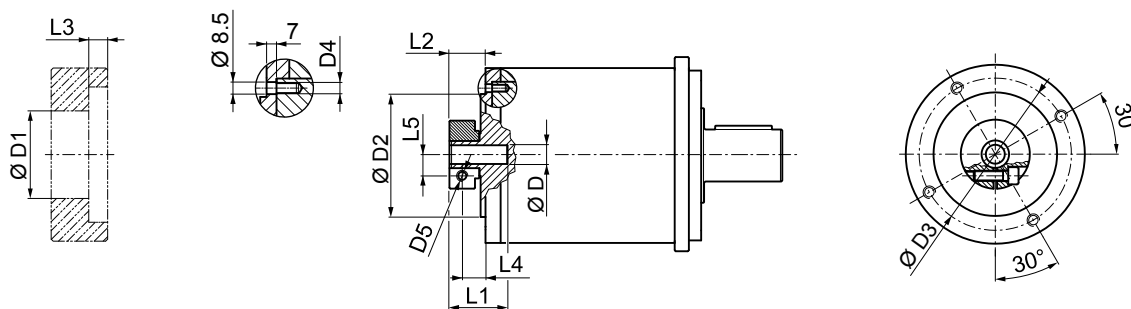

D	D1	D2	D3	D4	D5	L1	L2	L3	L4	L5	
14	16	48	130	142.5	M8x14	M6	45.5	27.5	6	20	14.5
19	16	51	130	142.5	M8x14	M6	45.5	27.5	6	20	16.5
22	24	56.5	130	142.5	M8x14	M6	47	29	6	20	19
28	24	67	130	142.5	M8x14	M8	47	29	6	20	22.5
32	24	71	130	142.5	M8x14	M8	47	29	6	20	24.5
35	24	73	130	142.5	M8x14	M8	54.5	36.5	6	25	26
38	24	77.5	130	142.5	M8x14	M8	54.5	36.5	6	25	28
42	24	92	130	142.5	M8x14	M10	60.5	40	6	25	33
45	24	95	130	142.5	M8x14	M10	60.5	40	6	25	33
48	24	97	130	142.5	M8x14	M10	60.5	40	6	25	33

TR 190

	i	M _{n 2}	M _{a 2}	M _{p 2}	n ₁	n _{1 max}	φ _s	φ _R	C _t	R _{2 max}	A _{2 max}	η	J _e [kgcm ²]				
		[Nm]	[Nm]	[Nm]	[min ⁻¹]	[min ⁻¹]	[arcmin]	[$\frac{Nm}{arcmin}$]	[N]	[N]	%	14 ... 24	28 - 32	35 - 35	42	45 - 48	
TR 190 1_3		500	800	1400	1500	2500	5'	3'	130	14000	15000	97	24.20	24.88	25.65	29.30	29.90
TR 190 1_4		700	950	1800	2100	3000	5'	3'	130	14000	15000	97	13.41	14.09	14.85	18.51	19.11
TR 190 1_5		700	950	1800	2300	3000	5'	3'	130	14000	15000	97	9.32	10.00	10.77	14.42	15.02
TR 190 1_6		700	950	1800	2300	3000	5'	3'	130	14000	15000	97	2.88	3.56	4.33	7.98	8.58
TR 190 1_7		700	950	1800	2900	3500	5'	3'	130	14000	15000	97	5.68	6.36	7.13	10.78	11.38
TR 190 1_10		500	800	1400	2900	3500	5'	3'	130	14000	15000	97	3.57	4.25	5.02	8.67	9.27
TR 190 2_9		500	800	1400	1500	2500	5'	3'	100	14000	15000	94	23.23	23.91	24.67	28.33	28.93
TR 190 2_12		1000	1200	2200	1500	2500	5'	3'	100	14000	15000	94	22.03	22.71	23.48	27.13	27.73
TR 190 2_15		1000	1200	2200	1500	2500	5'	3'	100	14000	15000	94	21.58	22.25	23.02	26.68	27.27
TR 190 2_16		1000	1200	2200	2100	3000	5'	3'	100	14000	15000	94	12.19	12.86	13.63	17.29	17.89
TR 190 2_20		1000	1200	2200	2300	3000	5'	3'	100	14000	15000	94	8.54	9.22	9.98	13.64	14.24
TR 190 2_25		1000	1200	2200	2300	3000	5'	3'	100	14000	15000	94	8.37	9.05	9.82	13.48	14.07
TR 190 2_28		1000	1200	2200	2900	3500	5'	3'	100	14000	15000	94	5.28	5.96	6.73	10.38	10.98
TR 190 2_30		500	800	1400	2900	3500	5'	3'	100	14000	15000	94	3.48	4.16	4.93	8.58	9.18
TR 190 2_35		1000	1200	2200	2900	3500	5'	3'	100	14000	15000	94	5.20	5.87	6.64	10.30	10.90
TR 190 2_36		700	950	1800	2300	3000	5'	3'	100	14000	15000	94	2.18	2.86	3.63	7.28	7.88
TR 190 2_40		1000	1200	2200	2900	3500	5'	3'	100	14000	15000	94	3.37	4.05	4.82	8.48	9.07
TR 190 2_50		1000	1200	2200	2900	3500	5'	3'	100	14000	15000	94	3.33	4.01	4.78	8.44	9.03
TR 190 2_70		1000	1200	2200	2900	3500	5'	3'	100	14000	15000	94	3.30	3.97	4.74	8.40	9.00
TR 190 2_100		500	800	1400	2900	3500	5'	3'	100	14000	15000	94	3.28	3.95	4.72	8.38	8.98
TR 190 3_48		1000	1200	2200	2100	3000	7'	5'	90	14000	15000	91	12.73	13.40	14.17	17.83	18.43
TR 190 3_64		1000	1200	2200	2100	3000	7'	5'	90	14000	15000	91	12.10	12.78	13.55	17.21	17.80
TR 190 3_75		1000	1200	2200	2300	3000	7'	5'	90	14000	15000	91	8.86	9.54	10.31	13.97	14.56
TR 190 3_80		1000	1200	2200	2100	3000	7'	5'	90	14000	15000	91	12.09	12.76	13.53	17.19	17.79
TR 190 3_84		1000	1200	2200	2900	3500	7'	5'	90	14000	15000	91	5.46	6.13	6.90	10.56	11.16
TR 190 3_90		500	800	1400	2900	3500	7'	5'	90	14000	15000	91	3.47	4.15	4.92	8.57	9.17
TR 190 3_120		1000	1200	2200	2900	3500	7'	5'	90	14000	15000	91	3.46	4.14	4.91	8.56	9.16
TR 190 3_125		1000	1200	2200	2300	3000	7'	5'	90	14000	15000	91	8.34	9.01	9.78	13.44	14.04
TR 190 3_140		1000	1200	2200	2900	3500	7'	5'	90	14000	15000	91	5.25	5.92	6.69	10.35	10.95
TR 190 3_150		1000	1200	2200	2900	3500	7'	5'	90	14000	15000	91	3.46	4.13	4.90	8.56	9.15
TR 190 3_160		1000	1200	2200	2900	3500	7'	5'	90	14000	15000	91	3.36	4.04	4.81	8.46	9.06
TR 190 3_175		1000	1200	2200	2900	3500	7'	5'	90	14000	15000	91	5.18	5.85	6.62	10.28	10.88
TR 190 3_200		1000	1200	2200	2900	3500	7'	5'	90	14000	15000	91	3.36	4.03	4.80	8.46	9.06
TR 190 3_210		1000	1200	2200	2900	3500	7'	5'	90	14000	15000	91	3.45	4.13	4.90	8.55	9.15
TR 190 3_250		1000	1200	2200	2900	3500	7'	5'	90	14000	15000	91	3.32	4.00	4.77	8.42	9.02
TR 190 3_280		1000	1200	2200	2900	3500	7'	5'	90	14000	15000	91	3.29	3.97	4.74	8.39	8.99
TR 190 3_350		1000	1200	2200	2900	3500	7'	5'	90	14000	15000	91	3.29	3.97	4.74	8.39	8.99
TR 190 3_400		1000	1200	2200	2900	3500	7'	5'	90	14000	15000	91	3.27	3.95	4.72	8.38	8.97
TR 190 3_500		1000	1200	2200	2900	3500	7'	5'	90	14000	15000	91	3.27	3.95	4.72	8.38	8.97
TR 190 3_700		1000	1200	2200	2900	3500	7'	5'	90	14000	15000	91	3.27	3.95	4.72	8.38	8.97
TR 190 3_1000		500	800	1400	2900	3500	7'	5'	90	14000	15000	91	3.27	3.95	4.72	8.38	8.97

TR

5.3.1 MACHINE SHAFT

Pivot of driven equipment should be made from high grade alloy steel. Table below shows recommended dimensions for the Customer to consider when designing mating shaft. A device retaining the shaft axially is also recommended (not shown). The number and size of relative tapped holes at shaft end depend on application requirements.

MB

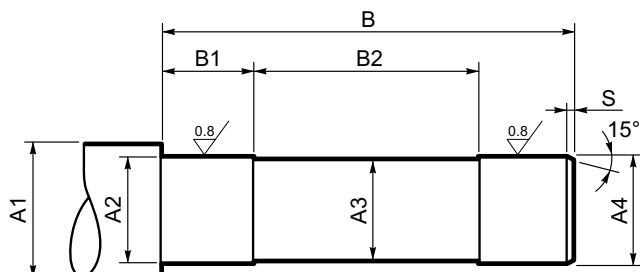

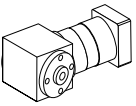
	A1	A2	A3	A4	B	B1	B2	S
TR MB 080	≥ 25	20 h7	18	20 h7	178	50	90	1
TR MB 105	≥ 40	32 h7	30	32 h7	205	60	115	
TR MB 130/160	≥ 50	42 h7	40	42 h7	259	70	140	

TR

MP PLANETARY PRECISION GEARBOX

MP planetary precision gearboxes are landmark for optimal performance, along with top reliability.

Available in different configuration (with input right angle; with output right angle; and hollow shaft, with solid input shaft), and servo-adapters to comply with most servomotors mechanical interface from the market.

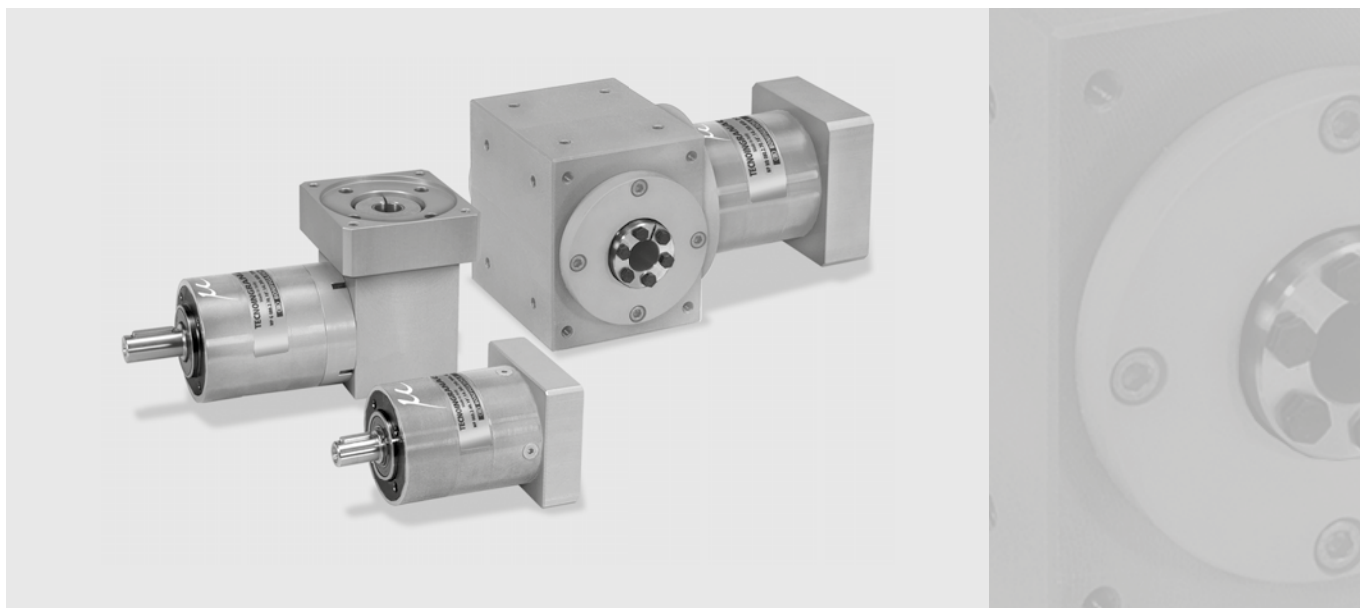

MP

Product Line Up:

- Higher Torque Density
- Higher Acceleration and Nominal Torques
- Higher Radial and Axial Load Capacities
- Designed for Cyclic and Continuous Duty
- Higher Torsional Stiffness
- Geometrical Backlash less than 10 arcmin
- Highest Flexibility (Low / Reduced Backlash; Standard / Reinforced Bearings)
- Different Constructive Version to match with your Specific Requirement.









6 FEATURES OF MP SERIES

Planetary gear units of the MP series belong to a range of low backlash drives very broad and complete as far as transmissible torque, gear ratios and circumferential backlash.

All units are generously proportioned to run quietly and provide a long service life without maintenance requirements.

Motor mounting is an operation that can be easily conducted without the need of any particular tooling, other than that usually available in a normally equipped workshop.

- Available with either standard (STD) or reduced (LOW) backlash:
 - 1-stage units: standard $\varphi_s \leq 15'$; reduced $\varphi_R \leq 10'$
 - 2-stage units: standard $\varphi_s \leq 15'$; reduced $\varphi_R \leq 10'$
 - 3-stage units (G and MB only): standard $\varphi_R \leq 15'$; reduced $\varphi_R \leq 10'$
 - 3-stage units: standard $\varphi_s \leq 17'$; reduced $\varphi_R \leq 12'$
 - 4-stage units (G and MB only): standard $\varphi_s \leq 17'$; reduced $\varphi_R \leq 12'$
- A high IP rating (IP65) provides inner parts with protection against the ingress of dust and liquids.
- Input section oil seals made from a Fluoroelastomer compound are supplied as standard.
- Noise pressure level $L_p \leq 70$ dB(A). Conditions: distance 1 m; measured without load an input speed of $n_1 = 3000$ min⁻¹; $i=10$.
- Bearings suitably rated for an average service life of 20,000 hours under nominal operating conditions. The following chart shows the types of bearings for the output shaft.

	MP 053	MP 060	MP 080	MP 105	MP 130	MP 160	MP 190
SB							
HB							

MP

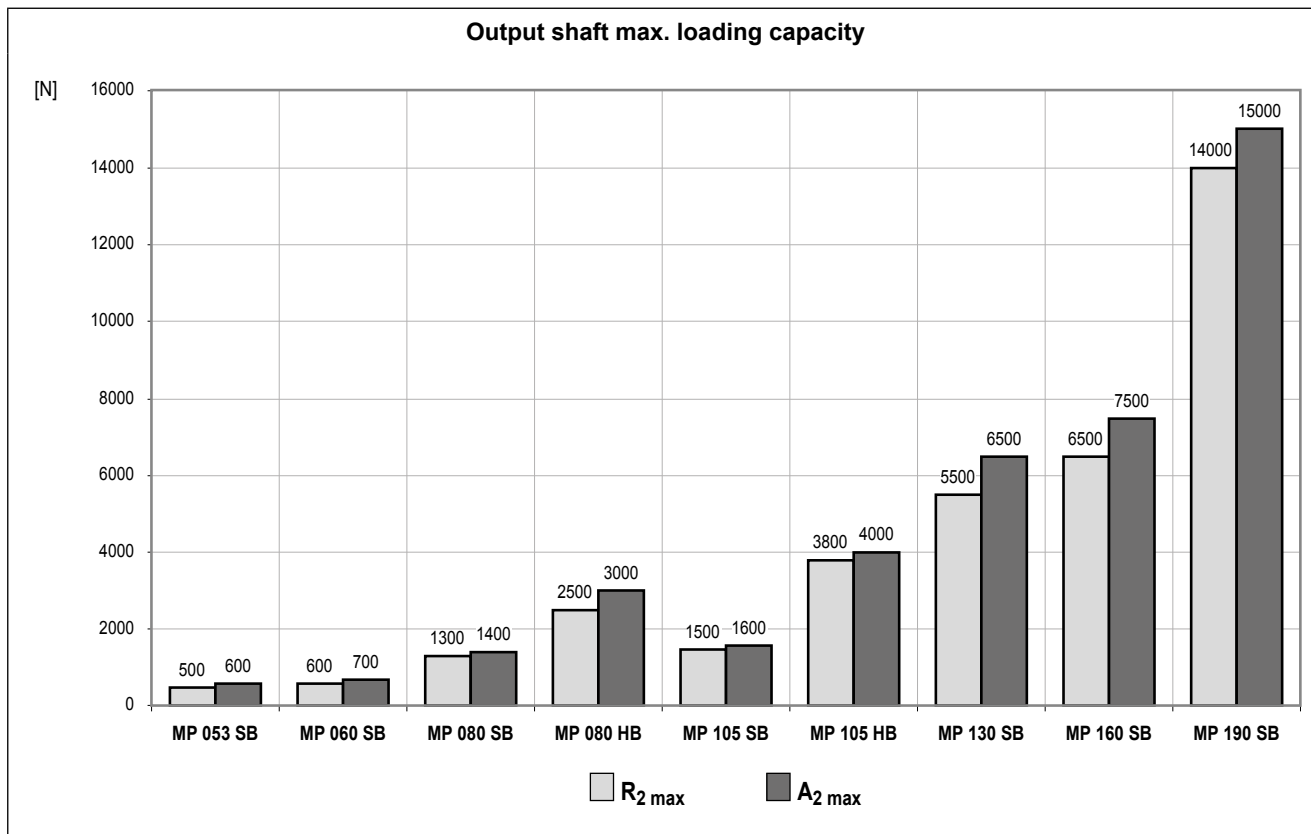

- Wide range of adapter flanges matching the most popular brands of motors.

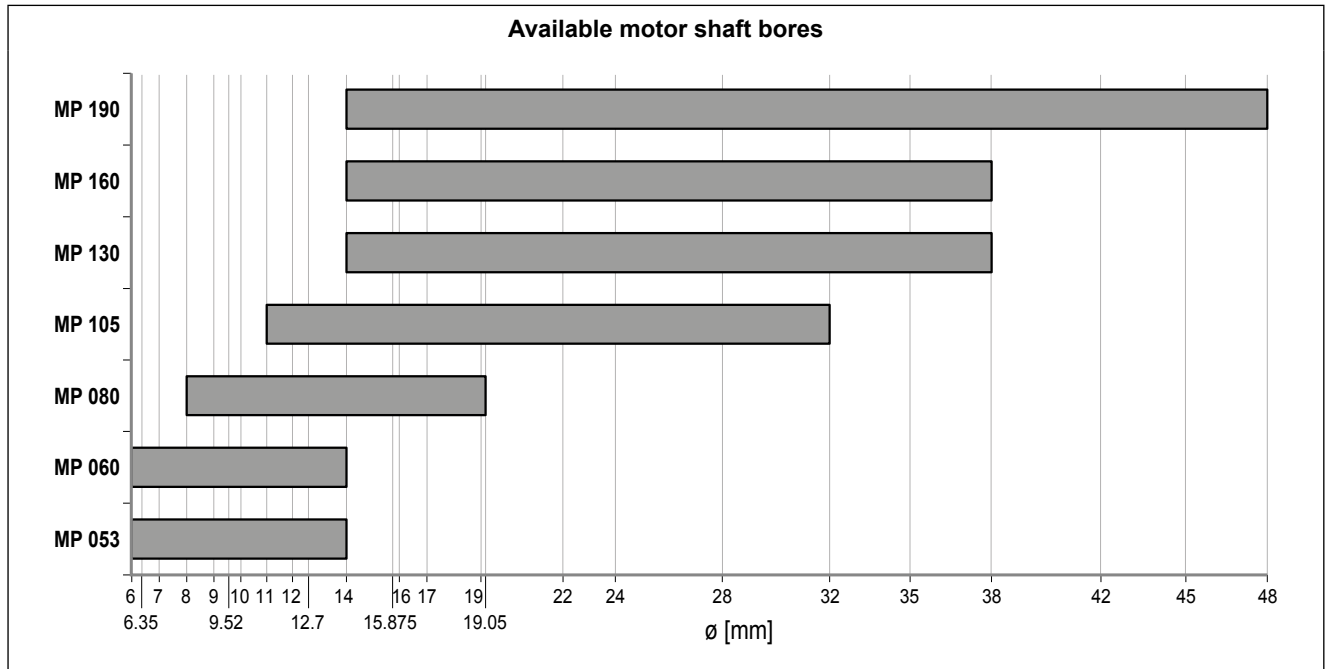

- Lubrication optimized for the type of duty specified when ordering.
In the absence of contamination the lubricant requires no periodical changes.

duty	MP 053 - MP 060	MP 080 ... MP 190	oil seals
S1 (continuous)	NLGI grease consistency 00	Synthetic oil viscosity ISO VG 220	Fluoroelastomer
S5 (intermittent)		NLGI grease consistency 00	NBR

- Ambient temperature min -20°C, max +30°C. For temperature higher than 30°C please consider derating factor f_T .
- Housing temperature must not exceed $T_{max} = 90^\circ\text{C}$.

		Distribution of nominal torque M_{n2} [Nm]																											
		3	4	5	6	7	9	10	12	15	16	20	25	28	30	35	36	40	45	48	50	60	64	70	75	80	81	84	90
MP 053	[I]	12	15	15	15	15	12	-	20	20	20	20	20	20	-	20	15	-	20	20	-	20	20	-	20	20	12	20	-
MP 060	[I]	18	25	25	25	25	18	18	30	30	30	30	30	30	18	30	25	30	-	30	30	-	30	30	30	30	-	30	18
MP 080	[I]	40	50	50	50	50	40	40	70	70	70	70	70	70	40	70	50	70	-	70	70	-	70	70	70	70	-	70	40
MP 105	[I]	100	140	140	140	140	100	100	170	170	170	170	170	170	100	170	140	170	-	170	170	-	170	170	170	170	-	170	100
MP 130	[I]	215	380	380	380	380	215	215	450	450	450	450	450	450	215	450	380	450	-	450	450	-	450	450	450	450	-	450	215
MP 160	[I]	350	500	500	500	500	350	350	700	700	700	700	700	700	350	700	500	700	-	700	700	-	700	700	700	700	-	700	350
MP 190	[I]	500	700	700	700	700	500	500	1000	1000	1000	1000	1000	1000	500	1000	700	1000	-	1000	1000	-	1000	1000	1000	1000	-	1000	500
		100	112	120	125	140	144	150	160	175	180	200	210	216	225	245	250	252	280	324	350	400	405	500	567	700	729	1000	
MP 053	[I]	20	20	-	20	20	20	-	-	20	20	-	-	20	20	20	-	20	-	20	-	-	20	-	20	-	12	-	
MP 060	[I]	18	-	30	30	30	-	30	30	30	-	30	30	30	-	-	30	-	30	-	30	30	-	30	-	30	-	18	
MP 080	[I]	40	-	70	70	70	-	70	70	70	-	70	70	70	-	-	70	-	70	-	70	70	-	70	-	70	-	40	
MP 105	[I]	100	-	170	170	170	-	170	170	170	-	170	170	170	-	-	170	-	170	-	170	170	-	170	-	170	-	100	
MP 130	[I]	215	-	450	450	450	-	450	450	450	-	450	450	450	-	-	450	-	450	-	450	450	-	450	-	450	-	215	
MP 160	[I]	350	-	700	700	700	-	700	700	700	-	700	700	700	-	-	700	-	700	-	700	700	-	700	-	700	-	350	
MP 190	[I]	500	-	1000	1000	1000	-	1000	1000	1000	-	1000	1000	1000	-	-	1000	-	1000	-	1000	1000	-	1000	-	1000	-	500	

S-M-BOR-NL-CAFS-001-V01

MP

6.1 ORDERING CODE

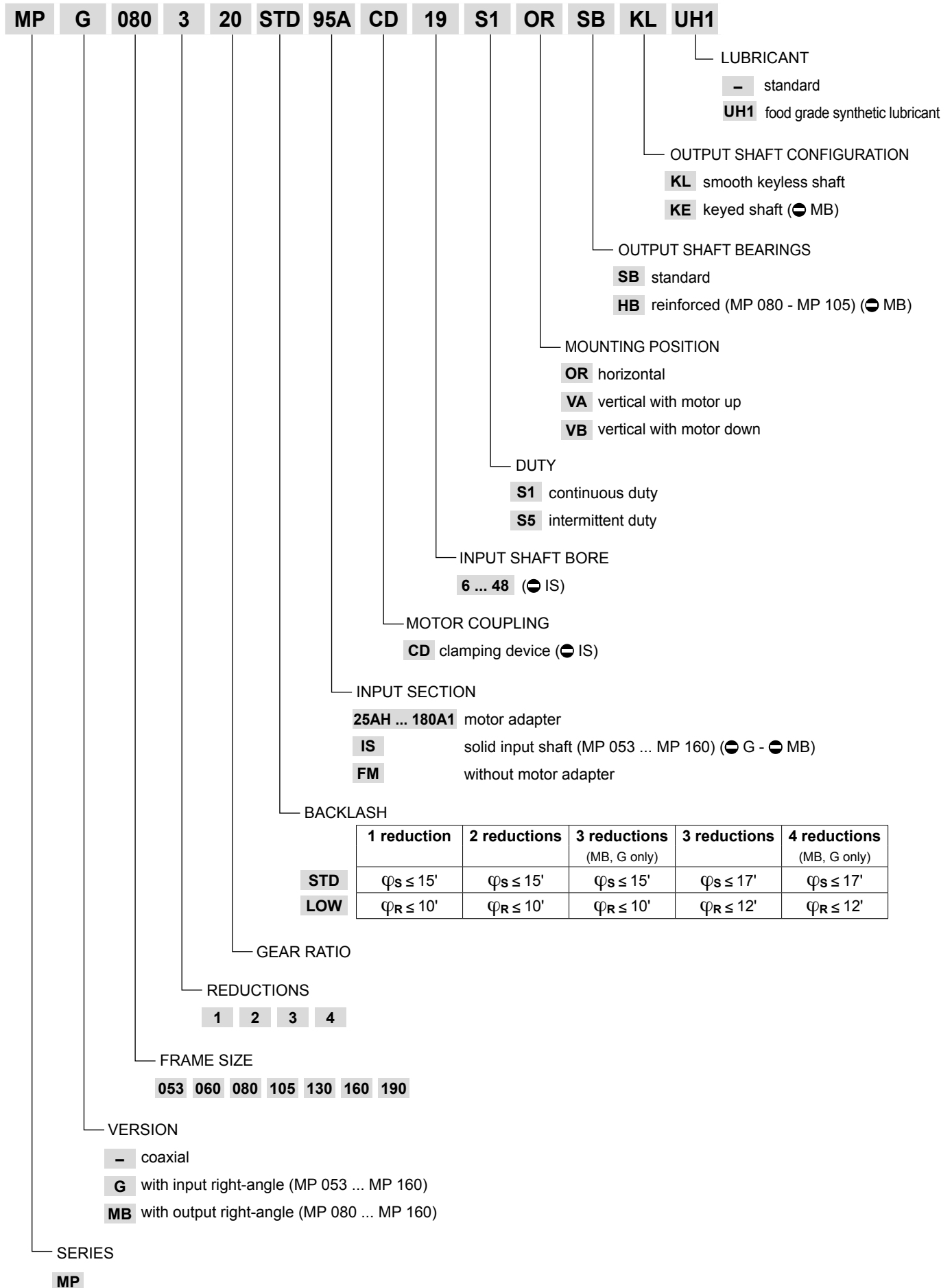

6.1.1 VERSION AND INPUT SECTION

		VERSION		
		coaxial (—)	with input right-angle (G)	with output right-angle (MB)
INPUT SECTION	25AH ... 180A1			
	IS			
	FM			

6.1.2 MOUNTING POSITIONS

	OR	VA	VB
—			
G			
MB			

6.2 ADMISSIBLE RADIAL AND AXIAL FORCES FOR MB VERSION

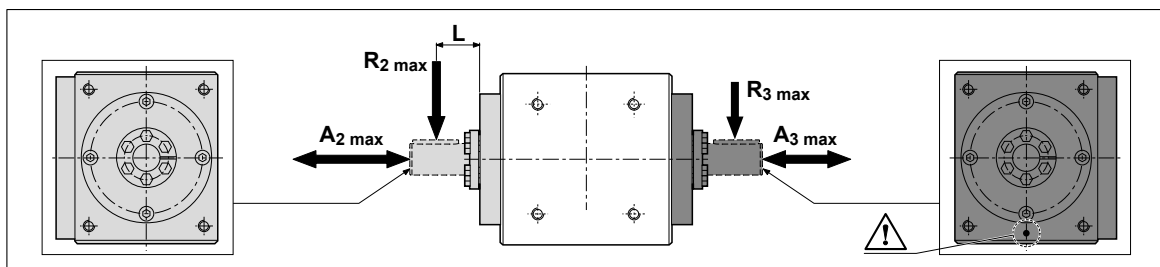

	R ₂ max [N]	A ₂ max [N]	L [mm]	R ₃ max [N]	A ₃ max [N]
MP MB 080	6000	5000	60	5500	5000
MP MB 105	9000	7500	80	7500	7500
MP MB 130	13500	11500	100	11000	11500
MP MB 160*	15000	11500	100	12500	11500

* Bearings suitably rated for an average service life of 10,000 hours under nominal operating conditions.

6.3 DIMENSIONS AND TECHNICAL SPECIFICATIONS

MP 053

IS

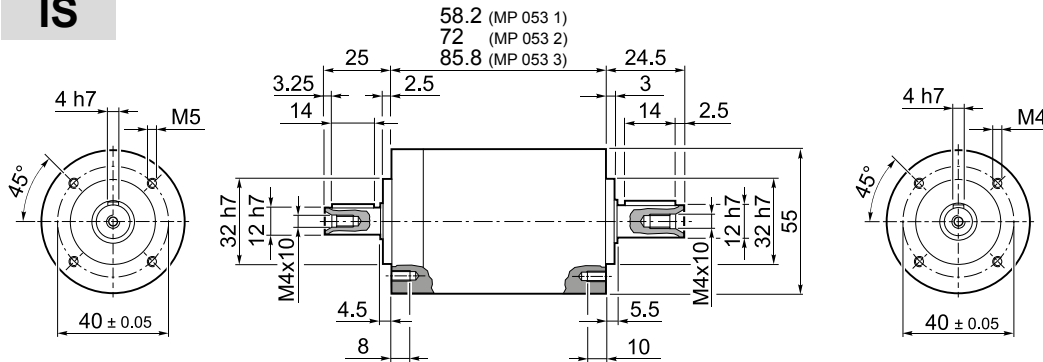

MP 053 1	0.8
MP 053 2	1.0
MP 053 3	1.3

25AH ... 80A

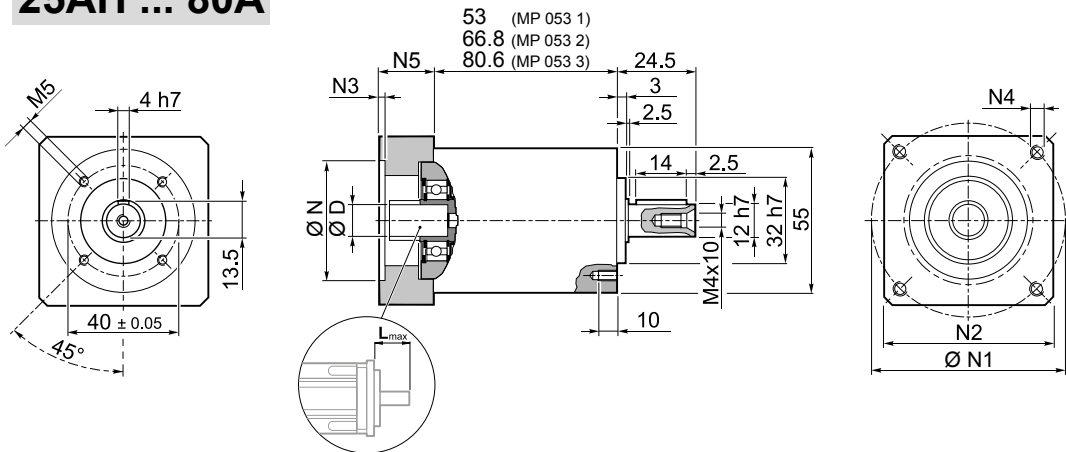

MP 053 1	0.8
MP 053 2	1.0
MP 053 3	1.3

MP

	D	N	N1		N2	N3	N4	N5	L _{max}
			min	max					
25AH	6 6.35 7 8 9 9.52 - - - - -	25	36	48					
26AH	6 6.35 7 8 9 9.52 - - - - -	26	36	48					
28AH	6 6.35 7 8 9 9.52 - - - - -	28	36	48					
30AH	6 6.35 7 8 9 9.52 - - - - -	30	36	48					
32AH	6 6.35 7 8 9 9.52 - - - - -	32	38	48	55	3.5	4.5	25	25
34AH	6 6.35 7 8 9 9.52 - - - - -	34	40	48					
36AH	6 6.35 7 8 9 9.52 - - - - -	36	42	48					
38AH	6 6.35 7 8 9 9.52 - - - - -	38	44	48					
40AH	6 6.35 7 8 9 9.52 - - - - -	40	46	48					
38B	6 6.35 7 8 9 9.52 10 11 12 12.7 -	38.1	66.6		60	3	M4x10	18	25
40B	6 6.35 7 8 9 9.52 10 11 12 12.7 -	40	63		60	3	M4x10	18	25
50A	6 6.35 7 8 9 9.52 10 11 12 12.7 -	50	60		60	3	M4x10	18	25
50B	6 6.35 7 8 9 9.52 10 11 12 12.7 14	50	65		60	3	M5x12	23	30
50BH	6 6.35 7 8 9 9.52 10 11 12 12.7 14	50	65		60	4	5.5	23	30
50C	6 6.35 7 8 9 9.52 10 11 12 12.7 14	50	70		60	3	M4x10	23	30
50MH	6 6.35 7 8 9 9.52 10 11 12 12.7 -	50	65		55	2	5.5	16	23
60A	6 6.35 7 8 9 9.52 10 11 12 12.7 -	60	75		63	3	M5x12	18	25
60AH	6 6.35 7 8 9 9.52 10 11 12 12.7 -	60	75		65	3	5.5	18	25
60A1	6 6.35 7 8 9 9.52 10 11 12 12.7 14	60	75		63	3	M5x12	23	30
60AH1	6 6.35 7 8 9 9.52 10 11 12 12.7 14	60	75		65	3	5.5	23	30
60B	6 6.35 7 8 9 9.52 10 11 12 12.7 14	60	85		75	3	M5x12	23	30
60C	6 6.35 7 8 9 9.52 10 11 12 12.7 14	60	90		75	3	M5x12	23	30
70A	6 6.35 7 8 9 9.52 10 11 12 12.7 14	70	85		75	3	M6x15	23	30
70B	6 6.35 7 8 9 9.52 10 11 12 12.7 14	70	90		75	3	M5x12	23	30
73A	6 6.35 7 8 9 9.52 10 11 12 12.7 14	73	98.4		85	3	M5x12	25	32
80A	6 6.35 7 8 9 9.52 10 11 12 12.7 14	80	100		85	3	M6x15	23	30



Please contact us for other motor adapters and input shaft bore.

MP 053

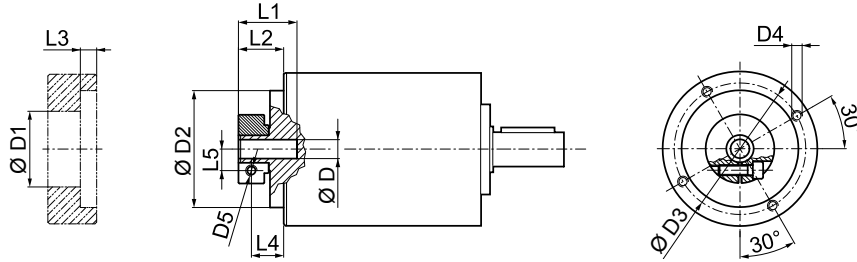
FM

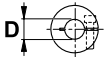

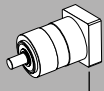
				D1	D2	D3	D4	D5	L1	L2	L3	L4	L5
6	6.35	7		32.5	50	42.5	M4x8	M4	20.2	13.2	3	8.7	8
8	9	9.52	10	32.5	50	42.5	M4x8	M4	20.2	13.2	3	7.8	9
11	12	12.7		35.5	50	42.5	M4x8	M4	20.5	13.5	3	8.5	11
14				35.5	50	42.5	M4x8	M4	24	17	3	10.2	11.5

	i	M _{n 2}	M _{a 2}	M _{p 2}	n ₁	n _{1 max}	ψ _S	ψ _R	C _t	R _{1 max}	R _{2 max}	A _{2 max}	η	J _G [kgcm ²]	
		[Nm]	[Nm]	[Nm]	[min ⁻¹]	[min ⁻¹]	[arcmin]	[arcmin]	[Nm/arcmin]	[N]	[N]	[N]	%	 6 ... 9.52	10 ... 14
MP 053 1_3		12	22	40	3300	4000	15'	10'	1.0	200	500	600	97	0.06	0.08
MP 053 1_4		15	28	45	3500	5000	15'	10'	1.0	200	500	600	97	0.05	0.06
MP 053 1_5		15	28	45	3500	5000	15'	10'	1.0	200	500	600	97	0.04	0.06
MP 053 1_6		15	28	45	3500	5000	15'	10'	1.0	200	500	600	97	0.03	0.05
MP 053 1_7		15	28	45	4000	6000	15'	10'	1.0	200	500	600	97	0.03	0.05
MP 053 1_9		12	22	40	4000	6000	15'	10'	1.0	200	500	600	97	0.03	0.05
MP 053 2_12		20	30	60	3300	4000	15'	10'	0.9	200	500	600	94	0.06	0.08
MP 053 2_15		20	30	60	3300	4000	15'	10'	0.9	200	500	600	94	0.06	0.08
MP 053 2_16		20	30	60	3500	5000	15'	10'	0.9	200	500	600	94	0.05	0.06
MP 053 2_20		20	30	60	3500	5000	15'	10'	0.9	200	500	600	94	0.04	0.06
MP 053 2_25		20	30	60	3500	5000	15'	10'	0.9	200	500	600	94	0.04	0.06
MP 053 2_28		20	30	60	4000	6000	15'	10'	0.9	200	500	600	94	0.03	0.05
MP 053 2_35		20	30	60	4000	6000	15'	10'	0.9	200	500	600	94	0.03	0.05
MP 053 2_36		15	28	45	4000	6000	15'	10'	0.9	200	500	600	94	0.03	0.05
MP 053 2_45		20	30	60	4000	6000	15'	10'	0.9	200	500	600	94	0.03	0.05
MP 053 2_81		12	22	40	3500	6000	15'	10'	0.9	200	500	600	94	0.03	0.05
MP 053 3_48		20	30	60	4000	5000	17'	12'	0.7	200	500	600	91	0.05	0.07
MP 053 3_60		20	30	60	3500	5000	17'	12'	0.7	200	500	600	91	0.05	0.07
MP 053 3_64		20	30	60	3500	5000	17'	12'	0.7	200	500	600	91	0.05	0.06
MP 053 3_75		20	30	60	3500	5000	17'	12'	0.7	200	500	600	91	0.04	0.06
MP 053 3_80		20	30	60	3500	5000	17'	12'	0.7	200	500	600	91	0.05	0.06
MP 053 3_84		20	30	60	4000	6000	17'	12'	0.7	200	500	600	91	0.03	0.05
MP 053 3_100		20	30	60	3500	5000	17'	12'	0.7	200	500	600	91	0.04	0.06
MP 053 3_112		20	30	60	4000	6000	17'	12'	0.7	200	500	600	91	0.03	0.05
MP 053 3_125		20	30	60	3500	5000	17'	12'	0.7	200	500	600	91	0.04	0.06
MP 053 3_140		20	30	60	4000	6000	17'	12'	0.7	200	500	600	91	0.03	0.05
MP 053 3_144		20	30	60	4000	6000	17'	12'	0.7	200	500	600	91	0.03	0.05
MP 053 3_175		20	30	60	4000	6000	17'	12'	0.7	200	500	600	91	0.03	0.05
MP 053 3_180		20	30	60	4000	6000	17'	12'	0.7	200	500	600	91	0.03	0.05
MP 053 3_216		20	30	60	3500	5000	17'	12'	0.7	200	500	600	91	0.03	0.05
MP 053 3_225		20	30	60	4000	6000	17'	12'	0.7	200	500	600	91	0.03	0.05
MP 053 3_245		20	30	60	4000	6000	17'	12'	0.7	200	500	600	91	0.03	0.05
MP 053 3_252		20	30	60	4000	6000	17'	12'	0.7	200	500	600	91	0.05	0.06
MP 053 3_324		20	30	60	4000	6000	17'	12'	0.7	200	500	600	91	0.03	0.05
MP 053 3_405		20	30	60	4000	6000	17'	12'	0.7	200	500	600	91	0.03	0.05
MP 053 3_567		20	30	60	4000	6000	17'	12'	0.7	200	500	600	91	0.03	0.05
MP 053 3_729		12	22	40	4000	6000	17'	12'	0.7	200	500	600	91	0.03	0.05

S-M-BOR-NL-CAFS-001-V01

MP

MP G 053

25AH ... 80A

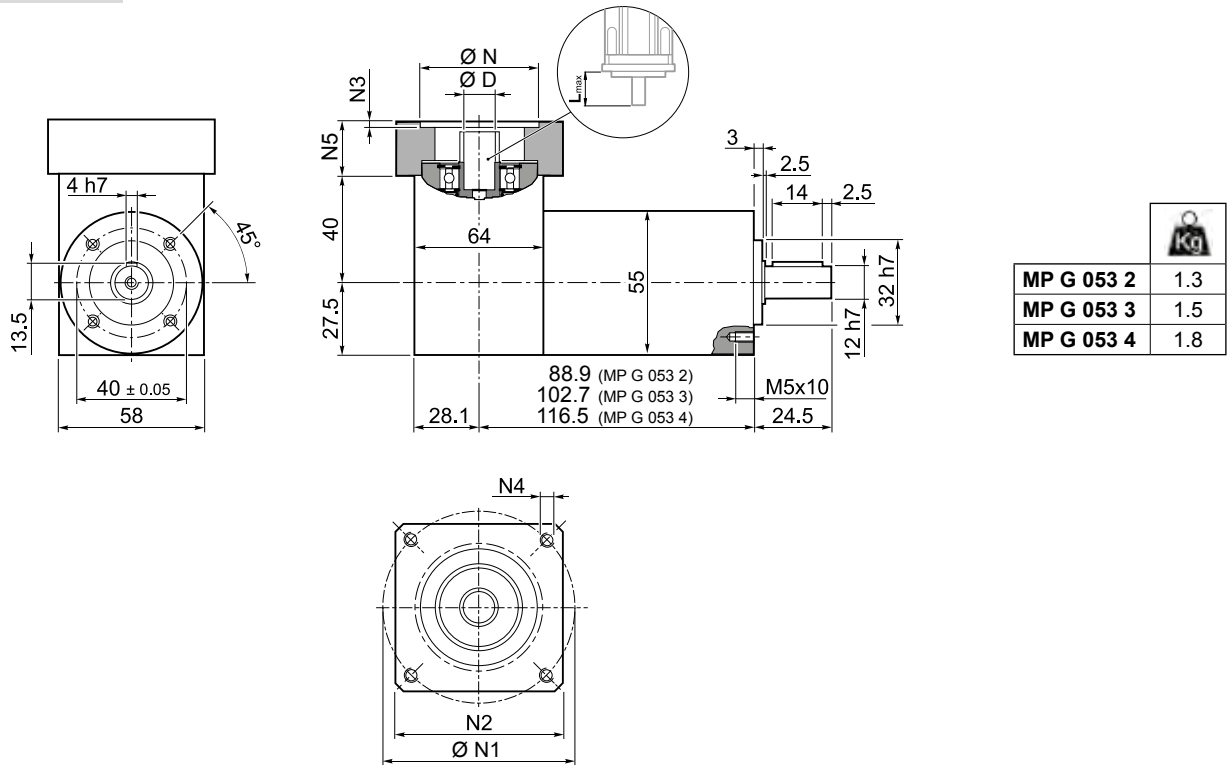

MP

Motor Model	D											N	N1		N2	N3	N4	N5	L _{max}
	6	6.35	7	8	9	9.52	-	-	-	-	-		min	max					
25AH	6	6.35	7	8	9	9.52	-	-	-	-	-	25	36	48					
26AH	6	6.35	7	8	9	9.52	-	-	-	-	-	26	36	48					
28AH	6	6.35	7	8	9	9.52	-	-	-	-	-	28	36	48					
30AH	6	6.35	7	8	9	9.52	-	-	-	-	-	30	36	48					
32AH	6	6.35	7	8	9	9.52	-	-	-	-	-	32	38	48	55	3.5	4.5	25	25
34AH	6	6.35	7	8	9	9.52	-	-	-	-	-	34	40	48					
36AH	6	6.35	7	8	9	9.52	-	-	-	-	-	36	42	48					
38AH	6	6.35	7	8	9	9.52	-	-	-	-	-	38	44	48					
40AH	6	6.35	7	8	9	9.52	-	-	-	-	-	40	46	48					
38B	6	6.35	7	8	9	9.52	10	11	12	12.7	-	38.1	66.6		60	3	M4x10	18	25
40B	6	6.35	7	8	9	9.52	10	11	12	12.7	-	40	63		60	3	M4x10	18	25
50A	6	6.35	7	8	9	9.52	10	11	12	12.7	-	50	60		60	3	M4x10	18	25
50B	6	6.35	7	8	9	9.52	10	11	12	12.7	14	50	65		60	3	M5x12	23	30
50BH	6	6.35	7	8	9	9.52	10	11	12	12.7	14	50	65		60	4	5.5	23	30
50C	6	6.35	7	8	9	9.52	10	11	12	12.7	14	50	70		60	3	M4x10	23	30
50MH	6	6.35	7	8	9	9.52	10	11	12	12.7	-	50	65		55	2	5.5	16	23
60A	6	6.35	7	8	9	9.52	10	11	12	12.7	-	60	75		63	3	M5x12	18	25
60A1	6	6.35	7	8	9	9.52	10	11	12	12.7	14	60	75		63	3	M5x12	23	30
60B	6	6.35	7	8	9	9.52	10	11	12	12.7	14	60	85		75	3	M5x12	23	30
60C	6	6.35	7	8	9	9.52	10	11	12	12.7	14	60	90		75	3	M5x12	23	30
70A	6	6.35	7	8	9	9.52	10	11	12	12.7	14	70	85		75	3	M6x15	23	30
70B	6	6.35	7	8	9	9.52	10	11	12	12.7	14	70	90		75	3	M5x12	23	30
73A	6	6.35	7	8	9	9.52	10	11	12	12.7	14	73	98.4		85	3	M5x12	25	32
80A	6	6.35	7	8	9	9.52	10	11	12	12.7	14	80	100		85	3	M6x15	23	30



Please contact us for other motor adapters and input shaft bore.

MP G 053

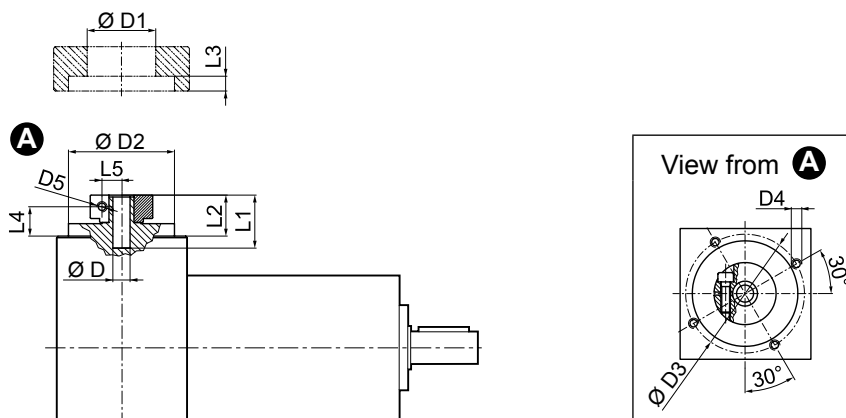
FM

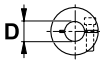

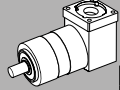
				D1	D2	D3	D4	D5	L1	L2	L3	L4	L5
6	6.35	7		32.5	50	42.5	M4x8	M4	20.2	13.2	3	8.7	8
8	9	9.52	10	32.5	50	42.5	M4x8	M4	20.2	13.2	3	7.8	9
11	12	12.7		35.5	50	42.5	M4x8	M4	20.5	13.5	3	8.5	11
14				35.5	50	42.5	M4x8	M4	24	17	3	10.2	11.5

	i	M _{n 2}	M _{a 2}	M _{p 2}	n ₁	n _{1 max}	φ _S	φ _R	C _t	R _{2 max}	A _{2 max}	η	J _G [kgcm ²]	
		[Nm]	[Nm]	[Nm]	[min ⁻¹]	[min ⁻¹]	[arcmin]	[arcmin]	$\left[\frac{Nm}{arcmin} \right]$	[N]	[N]	%		6 ... 9.52
MP G 053 2_3		12	22	40	3300	4000	15'	10'	1.0	500	600	94	0.18	0.20
MP G 053 2_4		15	28	45	3500	5000	15'	10'	1.0	500	600	94	0.18	0.19
MP G 053 2_5		15	28	45	3500	5000	15'	10'	1.0	500	600	94	0.17	0.19
MP G 053 2_6		15	28	45	3500	5000	15'	10'	1.0	500	600	94	0.17	0.18
MP G 053 2_7		15	28	45	4000	6000	15'	10'	1.0	500	600	94	0.17	0.19
MP G 053 2_9		12	22	40	4000	6000	15'	10'	1.0	500	600	94	0.17	0.18
MP G 053 3_12		20	30	60	3300	4000	15'	10'	0.9	500	600	91	0.18	0.20
MP G 053 3_15		20	30	60	3300	4000	15'	10'	0.9	500	600	91	0.18	0.20
MP G 053 3_16		20	30	60	3500	5000	15'	10'	0.9	500	600	91	0.17	0.19
MP G 053 3_20		20	30	60	3500	5000	15'	10'	0.9	500	600	91	0.17	0.19
MP G 053 3_25		20	30	60	3500	5000	15'	10'	0.9	500	600	91	0.17	0.19
MP G 053 3_28		20	30	60	4000	6000	15'	10'	0.9	500	600	91	0.17	0.19
MP G 053 3_35		20	30	60	4000	6000	15'	10'	0.9	500	600	91	0.17	0.19
MP G 053 3_36		15	28	45	4000	6000	15'	10'	0.9	500	600	91	0.17	0.18
MP G 053 3_45		20	30	60	4000	6000	15'	10'	0.9	500	600	91	0.17	0.19
MP G 053 3_81		12	22	40	3500	6000	15'	10'	0.9	500	600	91	0.17	0.18
MP G 053 4_48		20	30	60	4000	5000	17'	12'	0.7	500	600	89	0.18	0.19
MP G 053 4_60		20	30	60	3500	5000	17'	12'	0.7	500	600	89	0.18	0.19
MP G 053 4_64		20	30	60	3500	5000	17'	12'	0.7	500	600	89	0.17	0.19
MP G 053 4_75		20	30	60	3500	5000	17'	12'	0.7	500	600	89	0.17	0.19
MP G 053 4_80		20	30	60	3500	5000	17'	12'	0.7	500	600	89	0.17	0.19
MP G 053 4_84		20	30	60	4000	6000	17'	12'	0.7	500	600	89	0.17	0.19
MP G 053 4_100		20	30	60	3500	5000	17'	12'	0.7	500	600	89	0.17	0.19
MP G 053 4_112		20	30	60	4000	6000	17'	12'	0.7	500	600	89	0.17	0.19
MP G 053 4_125		20	30	60	3500	5000	17'	12'	0.7	500	600	89	0.17	0.19
MP G 053 4_140		20	30	60	4000	6000	17'	12'	0.7	500	600	89	0.17	0.19
MP G 053 4_144		20	30	60	4000	6000	17'	12'	0.7	500	600	89	0.17	0.18
MP G 053 4_175		20	30	60	4000	6000	17'	12'	0.7	500	600	89	0.17	0.19
MP G 053 4_180		20	30	60	4000	6000	17'	12'	0.7	500	600	89	0.17	0.18
MP G 053 4_216		20	30	60	3500	5000	17'	12'	0.7	500	600	89	0.17	0.18
MP G 053 4_225		20	30	60	4000	6000	17'	12'	0.7	500	600	89	0.17	0.18
MP G 053 4_245		20	30	60	4000	6000	17'	12'	0.7	500	600	89	0.17	0.19
MP G 053 4_252		20	30	60	4000	6000	17'	12'	0.7	500	600	89	0.18	0.20
MP G 053 4_324		20	30	60	4000	6000	17'	12'	0.7	500	600	89	0.17	0.18
MP G 053 4_405		20	30	60	4000	6000	17'	12'	0.7	500	600	89	0.17	0.18
MP G 053 4_567		20	30	60	4000	6000	17'	12'	0.7	500	600	89	0.17	0.18
MP G 053 4_729		12	22	40	4000	6000	17'	12'	0.7	500	600	89	0.17	0.18

MP

MP 060

IS

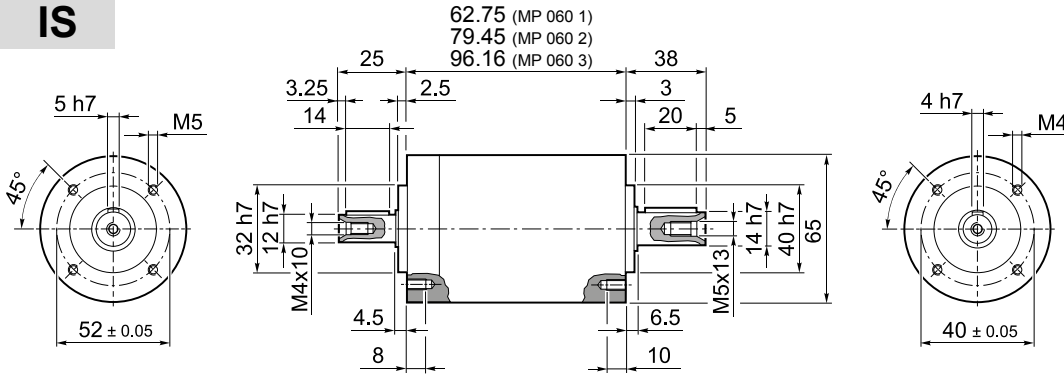

MP 060 1	1.2
MP 060 2	1.7
MP 060 3	2.0

25AH ... 80A

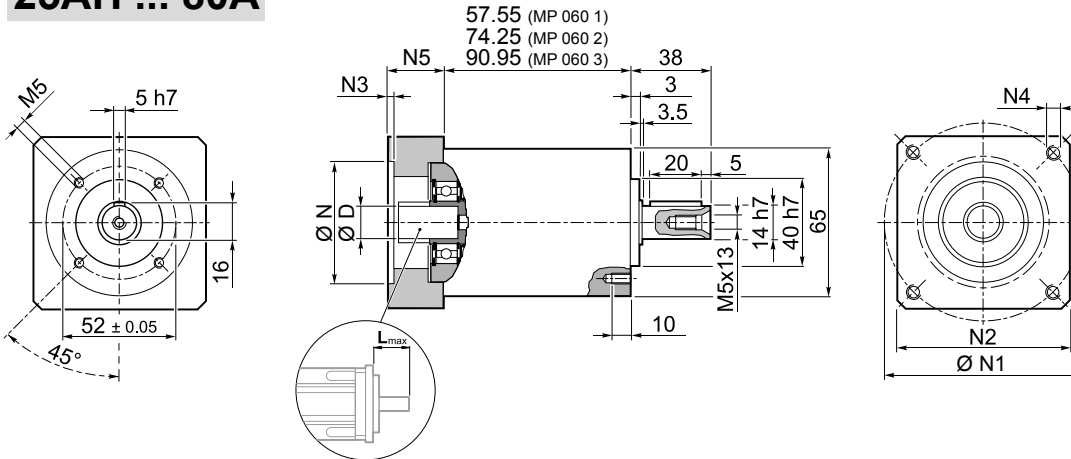

MP 060 1	1.2
MP 060 2	1.7
MP 060 3	2.0

MP

												N	N1		N2	N3	N4	N5	L _{max}
	6	6.35	7	8	9	9.52	-	-	-	-	-		min	max					
25AH	6	6.35	7	8	9	9.52	-	-	-	-	-	25	39	56					
26AH	6	6.35	7	8	9	9.52	-	-	-	-	-	26	39	56					
28AH	6	6.35	7	8	9	9.52	-	-	-	-	-	28	39	56					
30AH	6	6.35	7	8	9	9.52	-	-	-	-	-	30	39	56					
32AH	6	6.35	7	8	9	9.52	-	-	-	-	-	32	39	56	65	3.5	4.5	25	
34AH	6	6.35	7	8	9	9.52	-	-	-	-	-	34	40	56					
36AH	6	6.35	7	8	9	9.52	-	-	-	-	-	36	42	56					
39AH	6	6.35	7	8	9	9.52	-	-	-	-	-	39	45	56					
40AH	6	6.35	7	8	9	9.52	-	-	-	-	-	40	46	56					
38B	6	6.35	7	8	9	9.52	10	11	12	12.7	-	38.1	66.6	60	3	M4x10	18	25	
40B	6	6.35	7	8	9	9.52	10	11	12	12.7	-	40	63	60	3	M4x10	18	25	
50A	6	6.35	7	8	9	9.52	10	11	12	12.7	-	50	60	60	3	M4x10	18	25	
50B	6	6.35	7	8	9	9.52	10	11	12	12.7	14	50	65	60	3	M5x12	23	30	
50BH	6	6.35	7	8	9	9.52	10	11	12	12.7	14	50	65	65	3	5.5	25	32	
50C	6	6.35	7	8	9	9.52	10	11	12	12.7	14	50	70	60	3	M4x10	23	30	
55MH	6	6.35	7	8	9	9.52	10	11	12	12.7	-	55	80	65	2	5.5	16	23	
60A	6	6.35	7	8	9	9.52	10	11	12	12.7	-	60	75	63	3	M5x12	18	25	
60AH	6	6.35	7	8	9	9.52	10	11	12	12.7	-	60	75	65	3	5.5	18	25	
60A1	6	6.35	7	8	9	9.52	10	11	12	12.7	14	60	75	63	3	M5x12	23	30	
60AH1	6	6.35	7	8	9	9.52	10	11	12	12.7	14	60	75	65	3	5.5	23	30	
60B	6	6.35	7	8	9	9.52	10	11	12	12.7	14	60	85	75	3	M5x12	23	30	
60C	6	6.35	7	8	9	9.52	10	11	12	12.7	14	60	90	75	3	M5x12	23	30	
70A	6	6.35	7	8	9	9.52	10	11	12	12.7	14	70	85	75	3	M6x15	23	30	
70B	6	6.35	7	8	9	9.52	10	11	12	12.7	14	70	90	75	3	M5x12	23	30	
73A	6	6.35	7	8	9	9.52	10	11	12	12.7	14	73	98.4	85	3	M5x12	25	32	
80A	6	6.35	7	8	9	9.52	10	11	12	12.7	14	80	100	85	3	M6x15	23	30	

Please contact us for other motor adapters and input shaft bore.

MP 060

FM

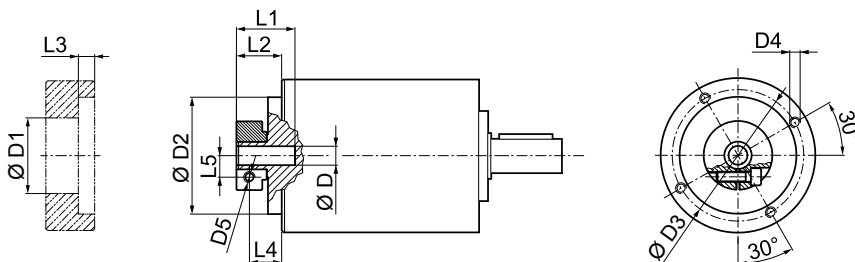

				D1	D2	D3	D4	D5	L1	L2	L3	L4	L5
6	6.35	7		32.5	50	42.5	M4x8	M4	20.2	13.2	3	8.7	8
8	9	9.52	10	32.5	50	42.5	M4x8	M4	20.2	13.2	3	7.8	9
11	12	12.7		35.5	50	42.5	M4x8	M4	20.5	13.5	3	8.5	11
14				35.5	50	42.5	M4x8	M4	24	17	3	10.2	11.5

	i	M _{n2}	M _{a2}	M _{p2}	n ₁	n _{1 max}	φ _S	φ _R	C _t	R _{1 max}	R _{2 max}	A _{2 max}	η	J _G [kgcm ²]	
		[Nm]	[Nm]	[Nm]	[min ⁻¹]	[min ⁻¹]	[arcmin]	[Nm/arcmin]	[N]	[N]	[N]	%		6 ... 9.52	10 ... 14
MP 060 1_3		18	35	70	3300	4000	15'	10'	3.0	200	600	700	97	0.10	0.11
MP 060 1_4		25	40	90	3500	5000	15'	10'	3.0	200	600	700	97	0.06	0.08
MP 060 1_5		25	40	90	3500	5000	15'	10'	3.0	200	600	700	97	0.05	0.07
MP 060 1_6		25	40	90	3500	5000	15'	10'	3.0	200	600	700	97	0.04	0.06
MP 060 1_7		25	40	90	4000	6000	15'	10'	3.0	200	600	700	97	0.04	0.06
MP 060 1_10		18	35	70	4000	6000	15'	10'	3.0	200	600	700	97	0.03	0.05
MP 060 2_9		18	35	70	3300	4000	15'	10'	2.5	200	600	700	94	0.10	0.12
MP 060 2_12		30	45	100	3300	4000	15'	10'	2.5	200	600	700	94	0.10	0.11
MP 060 2_15		30	45	100	3300	4000	15'	10'	2.5	200	600	700	94	0.09	0.11
MP 060 2_16		30	45	100	3500	5000	15'	10'	2.5	200	600	700	94	0.06	0.08
MP 060 2_20		30	45	100	3500	5000	15'	10'	2.5	200	600	700	94	0.05	0.07
MP 060 2_25		30	45	100	3500	5000	15'	10'	2.5	200	600	700	94	0.05	0.06
MP 060 2_28		30	45	100	4000	6000	15'	10'	2.5	200	600	700	94	0.04	0.06
MP 060 2_30		18	35	70	4000	6000	15'	10'	2.5	200	600	700	94	0.03	0.05
MP 060 2_35		30	45	100	4000	6000	15'	10'	2.5	200	600	700	94	0.04	0.06
MP 060 2_36		25	40	90	3500	5000	15'	10'	2.5	200	600	700	94	0.04	0.06
MP 060 2_40		30	45	100	4000	6000	15'	10'	2.5	200	600	700	94	0.03	0.05
MP 060 2_50		30	45	100	4000	6000	15'	10'	2.5	200	600	700	94	0.03	0.05
MP 060 2_70		30	45	100	4000	6000	15'	10'	2.5	200	600	700	94	0.03	0.05
MP 060 2_100		18	35	70	4000	6000	15'	10'	2.5	200	600	700	94	0.03	0.05
MP 060 3_48		30	45	100	3500	5000	17'	12'	1.8	200	600	700	91	0.06	0.08
MP 060 3_64		30	45	100	3500	5000	17'	12'	1.8	200	600	700	91	0.06	0.08
MP 060 3_75		30	45	100	3500	5000	17'	12'	1.8	200	600	700	91	0.05	0.07
MP 060 3_80		30	45	100	3500	5000	17'	12'	1.8	200	600	700	91	0.06	0.08
MP 060 3_84		30	45	100	4000	6000	17'	12'	1.8	200	600	700	91	0.04	0.06
MP 060 3_90		18	35	70	4000	6000	17'	12'	1.8	200	600	700	91	0.03	0.05
MP 060 3_120		30	45	100	4000	6000	17'	12'	1.8	200	600	700	91	0.03	0.05
MP 060 3_125		30	45	100	3500	5000	17'	12'	1.8	200	600	700	91	0.05	0.07
MP 060 3_140		30	45	100	4000	6000	17'	12'	1.8	200	600	700	91	0.04	0.06
MP 060 3_150		30	45	100	4000	6000	17'	12'	1.8	200	600	700	91	0.03	0.05
MP 060 3_160		30	45	100	4000	6000	17'	12'	1.8	200	600	700	91	0.03	0.05
MP 060 3_175		30	45	100	4000	6000	17'	12'	1.8	200	600	700	91	0.04	0.06
MP 060 3_200		30	45	100	4000	6000	17'	12'	1.8	200	600	700	91	0.03	0.05
MP 060 3_210		30	45	100	4000	6000	17'	12'	1.8	200	600	700	91	0.03	0.05
MP 060 3_216		30	45	100	3500	5000	17'	12'	1.8	200	600	700	91	0.04	0.06
MP 060 3_250		30	45	100	4000	6000	17'	12'	1.8	200	600	700	91	0.03	0.05
MP 060 3_280		30	45	100	4000	6000	17'	12'	1.8	200	600	700	91	0.03	0.05
MP 060 3_350		30	45	100	4000	6000	17'	12'	1.8	200	600	700	91	0.03	0.05
MP 060 3_400		30	45	100	4000	6000	17'	12'	1.8	200	600	700	91	0.03	0.05
MP 060 3_500		30	45	100	4000	6000	17'	12'	1.8	200	600	700	91	0.03	0.05
MP 060 3_700		30	45	100	4000	6000	17'	12'	1.8	200	600	700	91	0.03	0.05
MP 060 3_1000		18	35	70	4000	6000	17'	12'	1.8	200	600	700	91	0.03	0.05

MP

MP G 060

25AH ... 80A

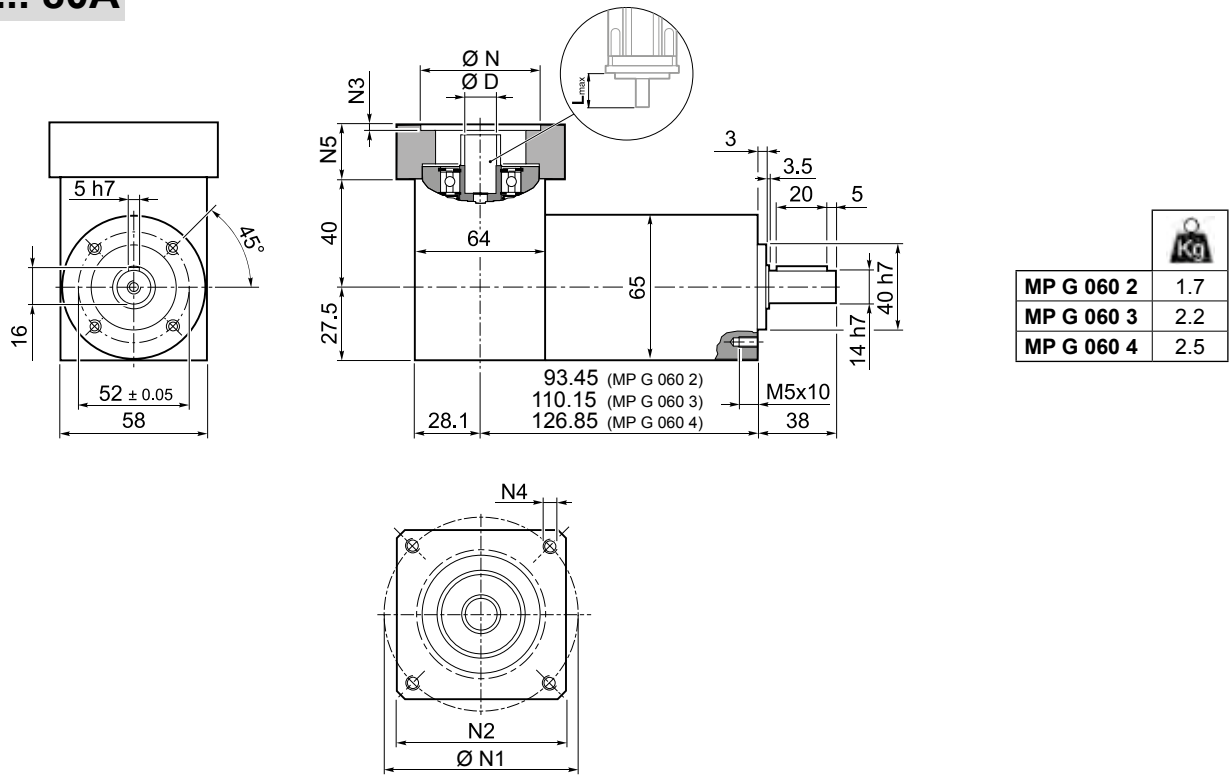

MP

	D										N	N1		N2	N3	N4	N5	L _{max}
	6	6.35	7	8	9	9.52	-	-	-	-		min	max					
25AH	6	6.35	7	8	9	9.52	-	-	-	-	25	39	56					
26AH	6	6.35	7	8	9	9.52	-	-	-	-	26	39	56					
28AH	6	6.35	7	8	9	9.52	-	-	-	-	28	39	56					
30AH	6	6.35	7	8	9	9.52	-	-	-	-	30	39	56					
32AH	6	6.35	7	8	9	9.52	-	-	-	-	32	39	56	65	3.5	4.5	25	25
34AH	6	6.35	7	8	9	9.52	-	-	-	-	34	40	56					
36AH	6	6.35	7	8	9	9.52	-	-	-	-	36	42	56					
39AH	6	6.35	7	8	9	9.52	-	-	-	-	39	45	56					
40AH	6	6.35	7	8	9	9.52	-	-	-	-	40	46	56					
38B	6	6.35	7	8	9	9.52	10	11	12	12.7	-	38.1	66.6	60	3	M4x10	18	25
40B	6	6.35	7	8	9	9.52	10	11	12	12.7	-	40	63	60	3	M4x10	18	25
50A	6	6.35	7	8	9	9.52	10	11	12	12.7	-	50	60	60	3	M4x10	18	25
50B	6	6.35	7	8	9	9.52	10	11	12	12.7	14	50	65	60	3	M5x12	23	30
50BH	6	6.35	7	8	9	9.52	10	11	12	12.7	14	50	65	65	3	5.5	25	32
50C	6	6.35	7	8	9	9.52	10	11	12	12.7	14	50	70	60	3	M4x10	23	30
55MH	6	6.35	7	8	9	9.52	10	11	12	12.7	-	55	80	65	2	5.5	16	23
60A	6	6.35	7	8	9	9.52	10	11	12	12.7	-	60	75	63	3	M5x12	18	25
60A1	6	6.35	7	8	9	9.52	10	11	12	12.7	14	60	75	63	3	M5x12	23	30
60B	6	6.35	7	8	9	9.52	10	11	12	12.7	14	60	85	75	3	M5x12	23	30
60C	6	6.35	7	8	9	9.52	10	11	12	12.7	14	60	90	75	3	M5x12	23	30
70A	6	6.35	7	8	9	9.52	10	11	12	12.7	14	70	85	75	3	M6x15	23	30
70B	6	6.35	7	8	9	9.52	10	11	12	12.7	14	70	90	75	3	M5x12	23	30
73A	6	6.35	7	8	9	9.52	10	11	12	12.7	14	73	98.4	85	3	M5x12	25	32
80A	6	6.35	7	8	9	9.52	10	11	12	12.7	14	80	100	85	3	M6x15	23	30

Please contact us for other motor adapters and input shaft bore.

MP G 060

FM

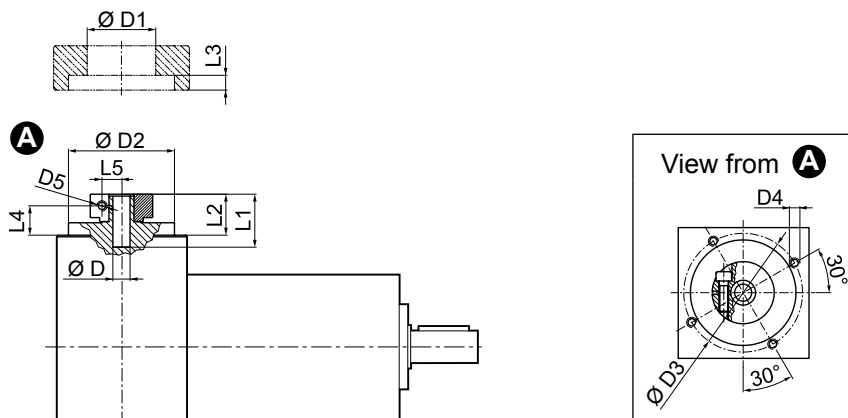

D			D1	D2	D3	D4	D5	L1	L2	L3	L4	L5
6	6.35	7	32.5	50	42.5	M4x8	M4	20.2	13.2	3	8.7	8
8	9	9.52	32.5	50	42.5	M4x8	M4	20.2	13.2	3	7.8	9
11	12	12.7	35.5	50	42.5	M4x8	M4	20.5	13.5	3	8.5	11
14			35.5	50	42.5	M4x8	M4	24	17	3	10.2	11.5

i	M _{n2} [Nm]	M _{a2} [Nm]	M _{p2} [Nm]	n ₁ [min ⁻¹]	n _{1 max} [min ⁻¹]	φ _S [arcmin]	φ _R [arcmin]	C _t [Nm/arcmin]	R _{2 max} [N]	A _{2 max} [N]	η %	J _e [kgcm ²]	
												D	6 ... 9.52
MP G 060 2_3	18	35	70	3300	4000	15'	10'	3.0	600	700	94	0.20	0.20
MP G 060 2_4	25	40	90	3500	5000	15'	10'	3.0	600	700	94	0.18	0.20
MP G 060 2_5	25	40	90	3500	5000	15'	10'	3.0	600	700	94	0.17	0.19
MP G 060 2_6	25	40	90	3500	5000	15'	10'	3.0	600	700	94	0.17	0.19
MP G 060 2_7	25	40	90	4000	6000	15'	10'	3.0	600	700	94	0.17	0.19
MP G 060 2_10	18	35	70	4000	6000	15'	10'	3.0	600	700	94	0.17	0.18
MP G 060 3_9	18	35	70	3300	4000	15'	10'	2.5	600	700	91	0.20	0.21
MP G 060 3_12	30	45	100	3300	4000	15'	10'	2.5	600	700	91	0.20	0.21
MP G 060 3_15	30	45	100	3300	4000	15'	10'	2.5	600	700	91	0.19	0.21
MP G 060 3_16	30	45	100	3500	5000	15'	10'	2.5	600	700	91	0.18	0.20
MP G 060 3_20	30	45	100	3500	5000	15'	10'	2.5	600	700	91	0.17	0.19
MP G 060 3_25	30	45	100	3500	5000	15'	10'	2.5	600	700	91	0.17	0.18
MP G 060 3_28	30	45	100	4000	6000	15'	10'	2.5	600	700	91	0.17	0.19
MP G 060 3_30	18	35	70	4000	6000	15'	10'	2.5	600	700	91	0.17	0.18
MP G 060 3_35	30	45	100	4000	6000	15'	10'	2.5	600	700	91	0.18	0.19
MP G 060 3_36	25	40	90	3500	5000	15'	10'	2.5	600	700	91	0.18	0.19
MP G 060 3_40	30	45	100	4000	6000	15'	10'	2.5	600	700	91	0.17	0.18
MP G 060 3_50	30	45	100	4000	6000	15'	10'	2.5	600	700	91	0.17	0.18
MP G 060 3_70	30	45	100	4000	6000	15'	10'	2.5	600	700	91	0.17	0.18
MP G 060 3_100	18	35	70	4000	6000	15'	10'	2.5	600	700	91	0.17	0.18
MP G 060 4_48	30	45	100	3500	5000	17'	12'	1.8	600	700	89	0.18	0.20
MP G 060 4_64	30	45	100	3500	5000	17'	12'	1.8	600	700	89	0.18	0.20
MP G 060 4_75	30	45	100	3500	5000	17'	12'	1.8	600	700	89	0.17	0.19
MP G 060 4_80	30	45	100	3500	5000	17'	12'	1.8	600	700	89	0.18	0.20
MP G 060 4_84	30	45	100	4000	6000	17'	12'	1.8	600	700	89	0.17	0.19
MP G 060 4_90	18	35	70	4000	6000	17'	12'	1.8	600	700	89	0.17	0.18
MP G 060 4_120	30	45	100	4000	6000	17'	12'	1.8	600	700	89	0.15	0.17
MP G 060 4_125	30	45	100	3500	5000	17'	12'	1.8	600	700	89	0.17	0.19
MP G 060 4_140	30	45	100	4000	6000	17'	12'	1.8	600	700	89	0.17	0.19
MP G 060 4_150	30	45	100	4000	6000	17'	12'	1.8	600	700	89	0.17	0.18
MP G 060 4_160	30	45	100	4000	6000	17'	12'	1.8	600	700	89	0.17	0.18
MP G 060 4_175	30	45	100	4000	6000	17'	12'	1.8	600	700	89	0.17	0.19
MP G 060 4_200	30	45	100	4000	6000	17'	12'	1.8	600	700	89	0.17	0.18
MP G 060 4_210	30	45	100	4000	6000	17'	12'	1.8	600	700	89	0.17	0.18
MP G 060 4_216	30	45	100	3500	5000	17'	12'	1.8	600	700	89	0.17	0.19
MP G 060 4_250	30	45	100	4000	6000	17'	12'	1.8	600	700	89	0.17	0.18
MP G 060 4_280	30	45	100	4000	6000	17'	12'	1.8	600	700	89	0.17	0.18
MP G 060 4_350	30	45	100	4000	6000	17'	12'	1.8	600	700	89	0.17	0.18
MP G 060 4_400	30	45	100	4000	6000	17'	12'	1.8	600	700	89	0.17	0.18
MP G 060 4_500	30	45	100	4000	6000	17'	12'	1.8	600	700	89	0.17	0.18
MP G 060 4_700	30	45	100	4000	6000	17'	12'	1.8	600	700	89	0.17	0.18
MP G 060 4_1000	18	35	70	4000	6000	17'	12'	1.8	600	700	89	0.17	0.18

MP

MP 080

IS

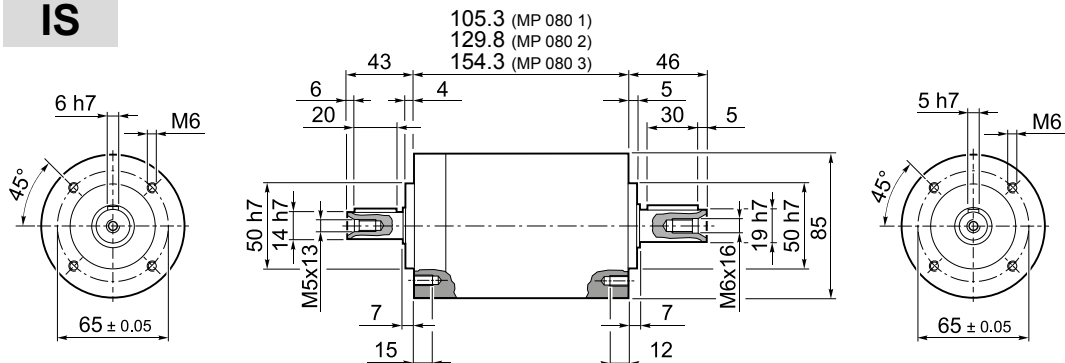

40B1 ... 110B1

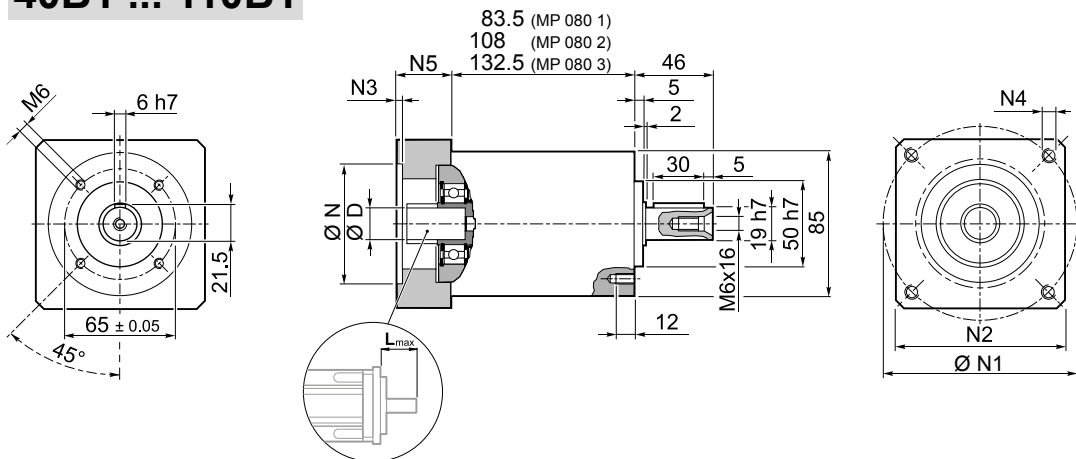

MP

	D											N	N1	N2	N3	N4	N5	L _{max}	
40B1	8	9	9.52	11	12	12.7	14	-	-	-	-	40	63	80	4	M4x12	34	40	
45A	8	9	9.52	11	12	12.7	-	-	-	-	-	45	63	80	4	M4x12	34	40	
50B1	8	9	9.52	11	12	12.7	14	-	-	-	-	50	65	80	4	M5x16	34	40	
50BH1	8	9	9.52	11	12	12.7	14	-	-	-	-	50	65	80	4	5.5	34	40	
50C1	8	9	9.52	11	12	12.7	14	-	-	-	-	50	70	80	4	M4x10	34	40	
50D	8	9	9.52	11	12	12.7	14	-	-	-	-	50	95	80	4	M6x20	34	40	
55A	8	9	9.52	11	12	12.7	14	15.875	16	17	19	19.05	55.5	125.7	105	4	M6x20	34	40
60A2	8	9	9.52	11	12	12.7	14	-	-	-	-	60	75	80	4	M5x16	34	40	
60AH2	8	9	9.52	11	12	12.7	14	-	-	-	-	60	75	90	4	6.5	34	40	
60B1	8	9	9.52	11	12	12.7	14	15.875	16	-	-	60	85	80	4	M5x16	34	40	
60C1	8	9	9.52	11	12	12.7	14	15.875	16	-	-	60	90	80	4	M5x16	34	40	
70A1	8	9	9.52	11	12	12.7	14	15.875	16	17	19	19.05	70	85	80	4	M6x20	34	40
70AH1	8	9	9.52	11	12	12.7	14	15.875	16	17	19	19.05	70	85	90	4	6.5	34	40
70B1	8	9	9.52	11	12	12.7	14	15.875	16	17	19	19.05	70	90	80	4	M5x16	34	40
73A1	8	9	9.52	11	12	12.7	14	-	-	-	-	73	98.4	85	4	M5x16	34	40	
80A1	8	9	9.52	11	12	12.7	14	15.875	16	17	19	19.05	80	100	90	4	M6x16	34	40
95A	8	9	9.52	11	12	12.7	14	15.875	16	17	19	19.05	95	115	100	4	M8x20	34	40
95B	8	9	9.52	11	12	12.7	14	15.875	16	17	19	19.05	95	130	115	4	M8x20	34	40
110A	8	9	9.52	11	12	12.7	14	15.875	16	17	19	19.05	110	130	115	4	M8x20	34	40
110B	8	9	9.52	11	12	12.7	14	15.875	16	17	19	19.05	110	145	120	6.5	M8x20	44	50
110B1	8	9	9.52	11	12	12.7	14	15.875	16	17	19	19.05	110	145	120	6.5	M8x20	54	60

Please contact us for other motor adapters and input shaft bore.

MP 080

FM

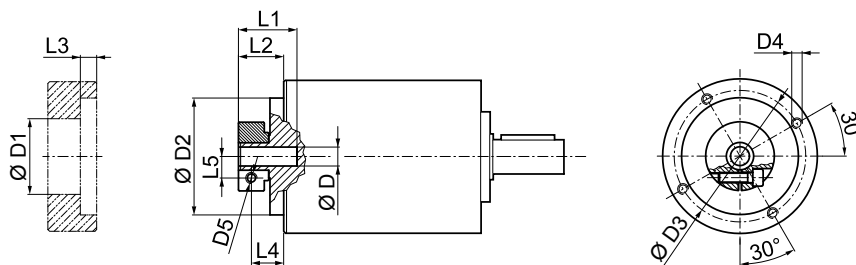

D			D1	D2	D3	D4	D5	L1	L2	L3	L4	L5
8	9	9.52	38	68	76.5	M6x12	M6	32.2	26.3	9.5	19.3	10.5
11	12	12.7	43	68	76.5	M6x12	M6	32.2	26.3	9.5	19.3	12.5
14	15.875	16	48	68	76.5	M6x12	M6	32.2	26.3	9.5	19.3	14.5
19	19.05		51	68	76.5	M6x12	M6	32.2	26.3	9.5	19.3	16.5

i	M _{n2} [Nm]	M _{a2} [Nm]	M _{p2} [Nm]	n ₁ [min ⁻¹]	n _{1 max} [min ⁻¹]	ψ _S [arcmin]	ψ _R [arcmin]	C _t [Nm/arcmin]	R _{1 max} [N]	R _{2 max} [N]	SB		HB		η ₁ %	J _G [kgcm ²]	
											A _{2 max} [N]	R _{2 max} [N]	A _{2 max} [N]	D		8 ... 12.7	14 ... 19.05
MP 080 1_3	40	80	180	2900	3500	15'	10'	7.0	400	1300	1400	2500	3000	97	0.50	0.59	
MP 080 1_4	50	80	200	3100	4500	15'	10'	7.0	400	1300	1400	2500	3000	97	0.34	0.43	
MP 080 1_5	50	80	200	3200	4500	15'	10'	7.0	400	1300	1400	2500	3000	97	0.28	0.37	
MP 080 1_6	50	80	200	3200	4500	15'	10'	7.0	400	1300	1400	2500	3000	97	0.21	0.30	
MP 080 1_7	50	80	200	4000	6000	15'	10'	7.0	400	1300	1400	2500	3000	97	0.23	0.32	
MP 080 1_10	40	80	180	4000	6000	15'	10'	7.0	400	1300	1400	2500	3000	97	0.20	0.29	
MP 080 2_9	40	80	180	2900	3500	15'	10'	5.9	400	1300	1400	2500	3000	94	0.49	0.58	
MP 080 2_12	70	100	250	2900	3500	15'	10'	5.9	400	1300	1400	2500	3000	94	0.47	0.56	
MP 080 2_15	70	100	250	2900	3500	15'	10'	5.9	400	1300	1400	2500	3000	94	0.46	0.55	
MP 080 2_16	70	100	250	3100	4500	15'	10'	5.9	400	1300	1400	2500	3000	94	0.32	0.41	
MP 080 2_20	70	100	250	3200	4500	15'	10'	5.9	400	1300	1400	2500	3000	94	0.27	0.36	
MP 080 2_25	70	100	250	3200	4500	15'	10'	5.9	400	1300	1400	2500	3000	94	0.27	0.36	
MP 080 2_28	70	100	250	4000	6000	15'	10'	5.9	400	1300	1400	2500	3000	94	0.22	0.31	
MP 080 2_30	40	80	180	4000	6000	15'	10'	5.9	400	1300	1400	2500	3000	94	0.20	0.29	
MP 080 2_35	70	100	250	4000	6000	15'	10'	5.9	400	1300	1400	2500	3000	94	0.22	0.31	
MP 080 2_36	50	80	200	3200	4500	15'	10'	5.9	400	1300	1400	2500	3000	94	0.20	0.29	
MP 080 2_40	70	100	250	4000	6000	15'	10'	5.9	400	1300	1400	2500	3000	94	0.20	0.29	
MP 080 2_50	70	100	250	4000	6000	15'	10'	5.9	400	1300	1400	2500	3000	94	0.19	0.28	
MP 080 2_70	70	100	250	4000	6000	15'	10'	5.9	400	1300	1400	2500	3000	94	0.19	0.28	
MP 080 2_100	40	80	180	4000	6000	15'	10'	5.9	400	1300	1400	2500	3000	94	0.19	0.28	
MP 080 3_48	70	100	250	3100	4500	17'	12'	5.4	400	1300	1400	2500	3000	91	0.33	0.42	
MP 080 3_64	70	100	250	3100	4500	17'	12'	5.4	400	1300	1400	2500	3000	91	0.32	0.41	
MP 080 3_75	70	100	250	3200	4500	17'	12'	5.4	400	1300	1400	2500	3000	91	0.27	0.36	
MP 080 3_80	70	100	250	3100	4500	17'	12'	5.4	400	1300	1400	2500	3000	91	0.32	0.41	
MP 080 3_84	70	100	250	4000	6000	17'	12'	5.4	400	1300	1400	2500	3000	91	0.23	0.32	
MP 080 3_90	40	80	180	4000	6000	17'	12'	5.4	400	1300	1400	2500	3000	91	0.20	0.29	
MP 080 3_120	70	100	250	4000	6000	17'	12'	5.4	400	1300	1400	2500	3000	91	0.20	0.29	
MP 080 3_125	70	100	250	3200	4500	17'	12'	5.4	400	1300	1400	2500	3000	91	0.27	0.36	
MP 080 3_140	70	100	250	4000	6000	17'	12'	5.4	400	1300	1400	2500	3000	91	0.22	0.31	
MP 080 3_150	70	100	250	4000	6000	17'	12'	5.4	400	1300	1400	2500	3000	91	0.20	0.29	
MP 080 3_160	70	100	250	4000	6000	17'	12'	5.4	400	1300	1400	2500	3000	91	0.20	0.29	
MP 080 3_175	70	100	250	4000	6000	17'	12'	5.4	400	1300	1400	2500	3000	91	0.22	0.31	
MP 080 3_200	70	100	250	4000	6000	17'	12'	5.4	400	1300	1400	2500	3000	91	0.20	0.29	
MP 080 3_210	70	100	250	4000	6000	17'	12'	5.4	400	1300	1400	2500	3000	91	0.20	0.29	
MP 080 3_216	70	100	250	3200	4500	17'	12'	5.4	400	1300	1400	2500	3000	91	0.20	0.29	
MP 080 3_250	70	100	250	4000	6000	17'	12'	5.4	400	1300	1400	2500	3000	91	0.19	0.28	
MP 080 3_280	70	100	250	4000	6000	17'	12'	5.4	400	1300	1400	2500	3000	91	0.19	0.28	
MP 080 3_350	70	100	250	4000	6000	17'	12'	5.4	400	1300	1400	2500	3000	91	0.19	0.28	
MP 080 3_400	70	100	250	4000	6000	17'	12'	5.4	400	1300	1400	2500	3000	91	0.19	0.28	
MP 080 3_500	70	100	250	4000	6000	17'	12'	5.4	400	1300	1400	2500	3000	91	0.19	0.28	
MP 080 3_700	70	100	250	4000	6000	17'	12'	5.4	400	1300	1400	2500	3000	91	0.19	0.28	
MP 080 3_1000	40	80	180	4000	6000	17'	12'	5.4	400	1300	1400	2500	3000	91	0.19	0.28	

MP

MP G 080

40B1 ... 110B1

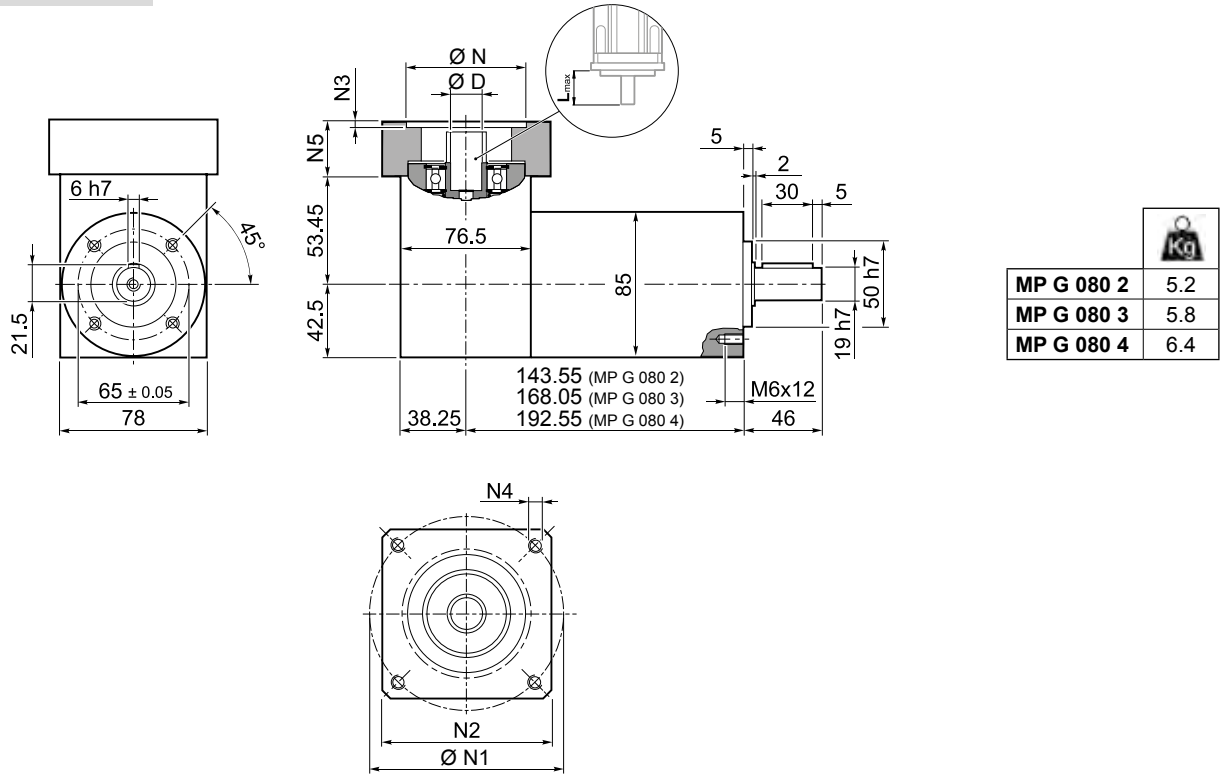

MP

											N	N1	N2	N3	N4	N5	L _{max}	
40B1	8	9	9.52	11	12	12.7	14	-	-	-	-	40	63	80	4	M4x12	34	40
45A	8	9	9.52	11	12	12.7	-	-	-	-	-	45	63	80	4	M4x12	34	40
50B1	8	9	9.52	11	12	12.7	14	-	-	-	-	50	65	80	4	M5x16	34	40
50BH1	8	9	9.52	11	12	12.7	14	-	-	-	-	50	65	80	4	5.5	34	40
50C1	8	9	9.52	11	12	12.7	14	-	-	-	-	50	70	80	4	M4x10	34	40
50D	8	9	9.52	11	12	12.7	14	-	-	-	-	50	95	80	4	M6x20	34	40
55A	8	9	9.52	11	12	12.7	14	15.875	16	17	19	55.5	125.7	105	4	M6x20	34	40
60A2	8	9	9.52	11	12	12.7	14	-	-	-	-	60	75	80	4	M5x16	34	40
60AH2	8	9	9.52	11	12	12.7	14	-	-	-	-	60	75	90	4	6.5	34	40
60B1	8	9	9.52	11	12	12.7	14	15.875	16	-	-	60	85	80	4	M5x16	34	40
60C1	8	9	9.52	11	12	12.7	14	15.875	16	-	-	60	90	80	4	M5x16	34	40
70A1	8	9	9.52	11	12	12.7	14	15.875	16	17	19	70	85	80	4	M6x20	34	40
70AH1	8	9	9.52	11	12	12.7	14	15.875	16	17	19	70	85	90	4	6.5	34	40
70B1	8	9	9.52	11	12	12.7	14	15.875	16	17	19	70	90	80	4	M5x16	34	40
73A1	8	9	9.52	11	12	12.7	14	-	-	-	-	73	98.4	85	4	M5x16	34	40
80A1	8	9	9.52	11	12	12.7	14	15.875	16	17	19	80	100	90	4	M6x16	34	40
95A	8	9	9.52	11	12	12.7	14	15.875	16	17	19	95	115	100	4	M8x20	34	40
95B	8	9	9.52	11	12	12.7	14	15.875	16	17	19	95	130	115	4	M8x20	34	40
110A	8	9	9.52	11	12	12.7	14	15.875	16	17	19	110	130	115	4	M8x20	34	40
110B	8	9	9.52	11	12	12.7	14	15.875	16	17	19	110	145	120	6.5	M8x20	44	50
110B1	8	9	9.52	11	12	12.7	14	15.875	16	17	19	110	145	120	6.5	M8x20	54	60

Please contact us for other motor adapters and input shaft bore.

MP G 080

FM

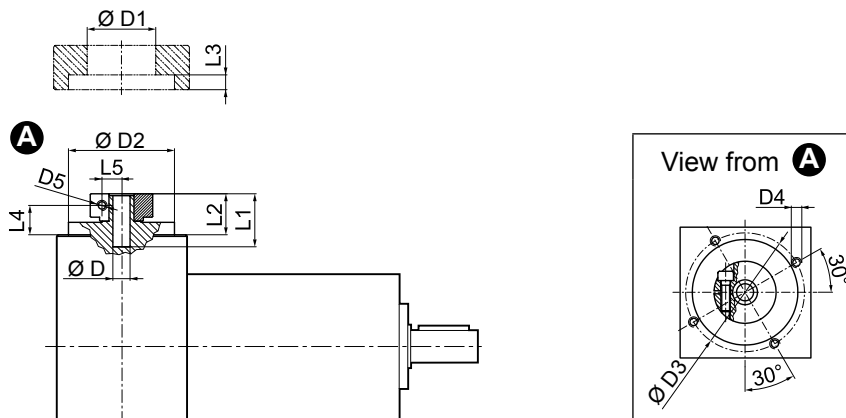

				D1	D2	D3	D4	D5	L1	L2	L3	L4	L5
8	9	9.52		38	68	76.5	M6x12	M6	32.2	26.3	9.5	19.3	10.5
11	12	12.7		43	68	76.5	M6x12	M6	32.2	26.3	9.5	19.3	12.5
14	15.875	16	17	48	68	76.5	M6x12	M6	32.2	26.3	9.5	19.3	14.5
19	19.05			51	68	76.5	M6x12	M6	32.2	26.3	9.5	19.3	16.5

	i	M _{n2} [Nm]	M _{a2} [Nm]	M _{p2} [Nm]	n ₁ [min ⁻¹]	n _{1 max} [min ⁻¹]	φ _S [arcmin]	φ _R [arcmin]	C _t [Nm/arcmin]	SB		HB		η %	J _G [kgcm ²]	
										R _{2 max} [N]	A _{2 max} [N]	R _{2 max} [N]	A _{2 max} [N]		8 ... 12.7	14 ... 19.05
MP G 080 2_3		40	80	180	2900	3500	15'	10'	7.0	1300	1400	2500	3000	94	0.67	0.79
MP G 080 2_4		50	80	200	3100	4500	15'	10'	7.0	1300	1400	2500	3000	94	0.62	0.75
MP G 080 2_5		50	80	200	3200	4500	15'	10'	7.0	1300	1400	2500	3000	94	0.61	0.74
MP G 080 2_6		50	80	200	3200	4500	15'	10'	7.0	1300	1400	2500	3000	94	0.58	0.71
MP G 080 2_7		50	80	200	4000	6000	15'	10'	7.0	1300	1400	2500	3000	94	0.60	0.73
MP G 080 2_10		40	80	180	4000	6000	15'	10'	7.0	1300	1400	2500	3000	94	0.60	0.72
MP G 080 3_9		40	80	180	2900	3500	15'	10'	5.9	1300	1400	2500	3000	91	0.66	0.78
MP G 080 3_12		70	100	250	2900	3500	15'	10'	5.9	1300	1400	2500	3000	91	0.75	0.87
MP G 080 3_15		70	100	250	2900	3500	15'	10'	5.9	1300	1400	2500	3000	91	0.74	0.87
MP G 080 3_16		70	100	250	3100	4500	15'	10'	5.9	1300	1400	2500	3000	91	0.60	0.73
MP G 080 3_20		70	100	250	3200	4500	15'	10'	5.9	1300	1400	2500	3000	91	0.60	0.73
MP G 080 3_25		70	100	250	3200	4500	15'	10'	5.9	1300	1400	2500	3000	91	0.64	0.76
MP G 080 3_28		70	100	250	4000	6000	15'	10'	5.9	1300	1400	2500	3000	91	0.59	0.72
MP G 080 3_30		40	80	180	4000	6000	15'	10'	5.9	1300	1400	2500	3000	91	0.60	0.72
MP G 080 3_35		70	100	250	4000	6000	15'	10'	5.9	1300	1400	2500	3000	91	0.61	0.74
MP G 080 3_36		50	80	200	3200	4500	15'	10'	5.9	1300	1400	2500	3000	91	0.57	0.70
MP G 080 3_40		70	100	250	4000	6000	15'	10'	5.9	1300	1400	2500	3000	91	0.60	0.72
MP G 080 3_50		70	100	250	4000	6000	15'	10'	5.9	1300	1400	2500	3000	91	0.59	0.71
MP G 080 3_70		70	100	250	4000	6000	15'	10'	5.9	1300	1400	2500	3000	91	0.59	0.71
MP G 080 3_100		40	80	180	4000	6000	15'	10'	5.9	1300	1400	2500	3000	91	0.59	0.71
MP G 080 4_48		70	100	250	3100	4500	17'	12'	5.4	1300	1400	2500	3000	89	0.61	0.75
MP G 080 4_64		70	100	250	3100	4500	17'	12'	5.4	1300	1400	2500	3000	89	0.60	0.73
MP G 080 4_75		70	100	250	3200	4500	17'	12'	5.4	1300	1400	2500	3000	89	0.60	0.73
MP G 080 4_80		70	100	250	3100	4500	17'	12'	5.4	1300	1400	2500	3000	89	0.60	0.73
MP G 080 4_84		70	100	250	4000	6000	17'	12'	5.4	1300	1400	2500	3000	89	0.60	0.73
MP G 080 4_90		40	80	180	4000	6000	17'	12'	5.4	1300	1400	2500	3000	89	0.60	0.72
MP G 080 4_120		70	100	250	4000	6000	17'	12'	5.4	1300	1400	2500	3000	89	0.60	0.72
MP G 080 4_125		70	100	250	3200	4500	17'	12'	5.4	1300	1400	2500	3000	89	0.60	0.73
MP G 080 4_140		70	100	250	4000	6000	17'	12'	5.4	1300	1400	2500	3000	89	0.59	0.72
MP G 080 4_150		70	100	250	4000	6000	17'	12'	5.4	1300	1400	2500	3000	89	0.60	0.72
MP G 080 4_160		70	100	250	4000	6000	17'	12'	5.4	1300	1400	2500	3000	89	0.60	0.72
MP G 080 4_175		70	100	250	4000	6000	17'	12'	5.4	1300	1400	2500	3000	89	0.59	0.72
MP G 080 4_200		70	100	250	4000	6000	17'	12'	5.4	1300	1400	2500	3000	89	0.60	0.72
MP G 080 4_210		70	100	250	4000	6000	17'	12'	5.4	1300	1400	2500	3000	89	0.60	0.72
MP G 080 4_216		70	100	250	3200	4500	17'	12'	5.4	1300	1400	2500	3000	89	0.57	0.70
MP G 080 4_250		70	100	250	4000	6000	17'	12'	5.4	1300	1400	2500	3000	89	0.59	0.71
MP G 080 4_280		70	100	250	4000	6000	17'	12'	5.4	1300	1400	2500	3000	89	0.59	0.71
MP G 080 4_350		70	100	250	4000	6000	17'	12'	5.4	1300	1400	2500	3000	89	0.59	0.71
MP G 080 4_400		70	100	250	4000	6000	17'	12'	5.4	1300	1400	2500	3000	89	0.59	0.71
MP G 080 4_500		70	100	250	4000	6000	17'	12'	5.4	1300	1400	2500	3000	89	0.59	0.71
MP G 080 4_700		70	100	250	4000	6000	17'	12'	5.4	1300	1400	2500	3000	89	0.59	0.71
MP G 080 4_1000		40	80	180	4000	6000	17'	12'	5.4	1300	1400	2500	3000	89	0.59	0.71

MP

MP MB 080

40B1 ... 110B1

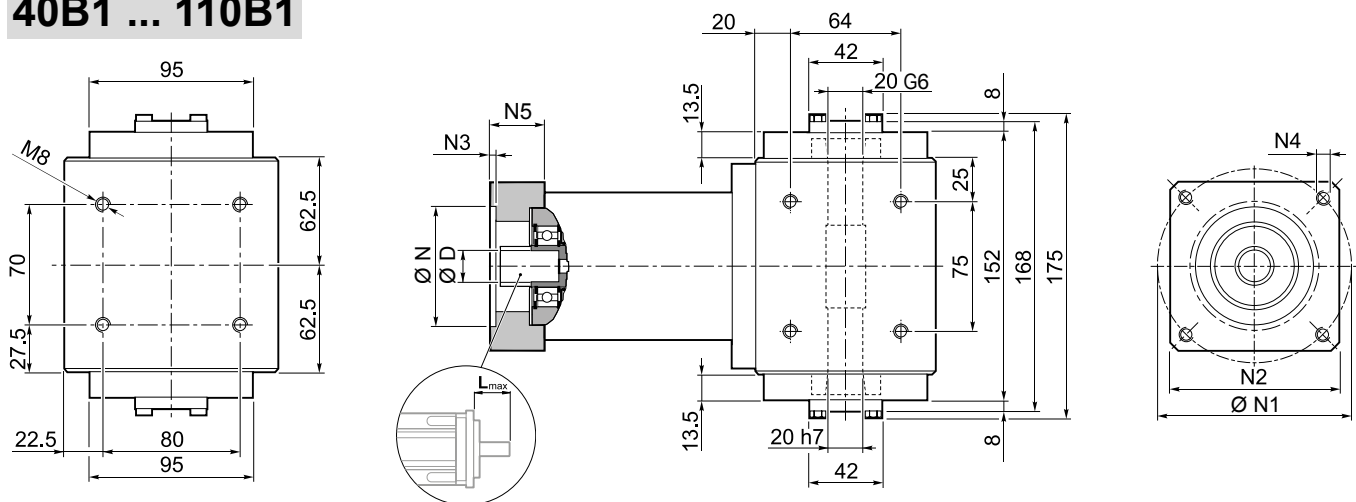

149.5 (MP MB 080 2)
174 (MP MB 080 3)
198.5 (MP MB 080 4)

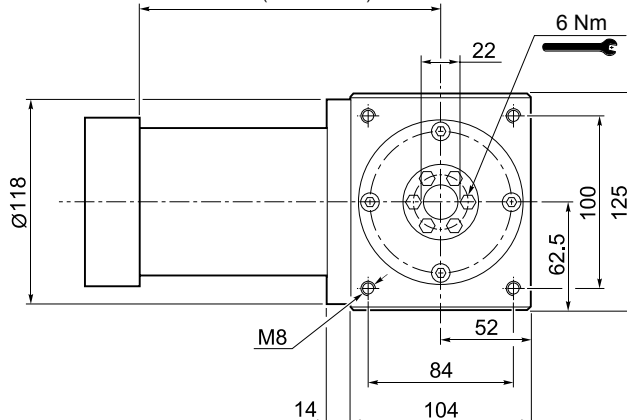

MP MB 080 2	14.0
MP MB 080 3	15.0
MP MB 080 4	16.0

MP

												N	N1	N2	N3	N4	N5	L _{max}	
40B1	8	9	9.52	11	12	12.7	14	-	-	-	-	40	63	80	4	M4x12	34	40	
45A	8	9	9.52	11	12	12.7	-	-	-	-	-	45	63	80	4	M4x12	34	40	
50B1	8	9	9.52	11	12	12.7	14	-	-	-	-	50	65	80	4	M5x16	34	40	
50BH1	8	9	9.52	11	12	12.7	14	-	-	-	-	50	65	80	4	5.5	34	40	
50C1	8	9	9.52	11	12	12.7	14	-	-	-	-	50	70	80	4	M4x10	34	40	
50D	8	9	9.52	11	12	12.7	14	-	-	-	-	50	95	80	4	M6x20	34	40	
55A	8	9	9.52	11	12	12.7	14	15.875	16	17	19	19.05	55.5	125.7	105	4	M6x20	34	40
60A2	8	9	9.52	11	12	12.7	14	-	-	-	-	60	75	80	4	M5x16	34	40	
60AH2	8	9	9.52	11	12	12.7	14	-	-	-	-	60	75	90	4	6.5	34	40	
60B1	8	9	9.52	11	12	12.7	14	15.875	16	-	-	60	85	80	4	M5x16	34	40	
60C1	8	9	9.52	11	12	12.7	14	15.875	16	-	-	60	90	80	4	M5x16	34	40	
70A1	8	9	9.52	11	12	12.7	14	15.875	16	17	19	19.05	70	85	80	4	M6x20	34	40
70AH1	8	9	9.52	11	12	12.7	14	15.875	16	17	19	19.05	70	85	90	4	6.5	34	40
70B1	8	9	9.52	11	12	12.7	14	15.875	16	17	19	19.05	70	90	80	4	M5x16	34	40
73A1	8	9	9.52	11	12	12.7	14	-	-	-	-	73	98.4	85	4	M5x16	34	40	
80A1	8	9	9.52	11	12	12.7	14	15.875	16	17	19	19.05	80	100	90	4	M6x16	34	40
95A	8	9	9.52	11	12	12.7	14	15.875	16	17	19	19.05	95	115	100	4	M8x20	34	40
95B	8	9	9.52	11	12	12.7	14	15.875	16	17	19	19.05	95	130	115	4	M8x20	34	40
110A	8	9	9.52	11	12	12.7	14	15.875	16	17	19	19.05	110	130	115	4	M8x20	34	40
110B	8	9	9.52	11	12	12.7	14	15.875	16	17	19	19.05	110	145	120	6.5	M8x20	44	50
110B1	8	9	9.52	11	12	12.7	14	15.875	16	17	19	19.05	110	145	120	6.5	M8x20	54	60

Please contact us for other motor adapters and input shaft bore.

MP MB 080

FM

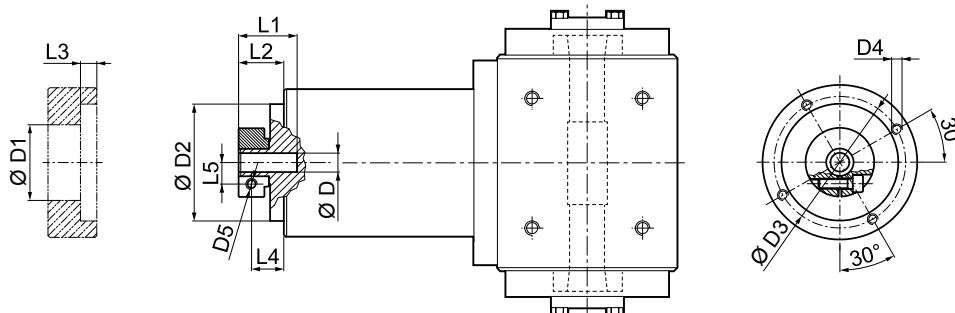

				D1	D2	D3	D4	D5	L1	L2	L3	L4	L5
8	9	9.52		38	68	76.5	M6x12	M6	32.2	26.3	9.5	19.3	10.5
11	12	12.7		43	68	76.5	M6x12	M6	32.2	26.3	9.5	19.3	12.5
14	15.875	16	17	48	68	76.5	M6x12	M6	32.2	26.3	9.5	19.3	14.5
19	19.05			51	68	76.5	M6x12	M6	32.2	26.3	9.5	19.3	16.5

	i	M _{n2} [Nm]	M _{a2} [Nm]	M _{p2} [Nm]	n ₁ [min ⁻¹]	n _{1 max} [min ⁻¹]	Ψ _S [arcmin]	Ψ _R [arcmin]	C _t [Nm/arcmin]	η %	J _G [kgcm ²]	
											8 ... 12.7	14 ... 19.05
MP MB 080 2_3		40	80	180	2900	3500	15'	10'	7.0	94	0.50	0.59
MP MB 080 2_4		50	80	200	3100	4500	15'	10'	7.0	94	0.34	0.43
MP MB 080 2_5		50	80	200	3200	4500	15'	10'	7.0	94	0.28	0.37
MP MB 080 2_6		50	80	200	3200	4500	15'	10'	7.0	94	0.21	0.30
MP MB 080 2_7		50	80	200	4000	6000	15'	10'	7.0	94	0.23	0.32
MP MB 080 2_10		40	80	180	4000	6000	15'	10'	7.0	94	0.20	0.29
MP MB 080 3_9		40	80	180	2900	3500	15'	10'	5.9	91	0.49	0.58
MP MB 080 3_12		70	100	250	2900	3500	15'	10'	5.9	91	0.47	0.56
MP MB 080 3_15		70	100	250	2900	3500	15'	10'	5.9	91	0.46	0.55
MP MB 080 3_16		70	100	250	3100	4500	15'	10'	5.9	91	0.32	0.41
MP MB 080 3_20		70	100	250	3200	4500	15'	10'	5.9	91	0.27	0.36
MP MB 080 3_25		70	100	250	3200	4500	15'	10'	5.9	91	0.27	0.36
MP MB 080 3_28		70	100	250	4000	6000	15'	10'	5.9	91	0.22	0.31
MP MB 080 3_30		40	80	180	4000	6000	15'	10'	5.9	91	0.20	0.29
MP MB 080 3_35		70	100	250	4000	6000	15'	10'	5.9	91	0.22	0.31
MP MB 080 3_36		50	80	200	3200	4500	15'	10'	5.9	91	0.20	0.29
MP MB 080 3_40		70	100	250	4000	6000	15'	10'	5.9	91	0.20	0.29
MP MB 080 3_50		70	100	250	4000	6000	15'	10'	5.9	91	0.19	0.28
MP MB 080 3_70		70	100	250	4000	6000	15'	10'	5.9	91	0.19	0.28
MP MB 080 3_100		40	80	180	4000	6000	15'	10'	5.9	91	0.19	0.28
MP MB 080 4_48		70	100	250	3100	4500	17'	12'	5.4	89	0.33	0.42
MP MB 080 4_64		70	100	250	3100	4500	17'	12'	5.4	89	0.32	0.41
MP MB 080 4_75		70	100	250	3200	4500	17'	12'	5.4	89	0.27	0.36
MP MB 080 4_80		70	100	250	3100	4500	17'	12'	5.4	89	0.32	0.41
MP MB 080 4_84		70	100	250	4000	6000	17'	12'	5.4	89	0.23	0.32
MP MB 080 4_90		40	80	180	4000	6000	17'	12'	5.4	89	0.20	0.29
MP MB 080 4_120		70	100	250	4000	6000	17'	12'	5.4	89	0.20	0.29
MP MB 080 4_125		70	100	250	3200	4500	17'	12'	5.4	89	0.27	0.36
MP MB 080 4_140		70	100	250	4000	6000	17'	12'	5.4	89	0.22	0.31
MP MB 080 4_150		70	100	250	4000	6000	17'	12'	5.4	89	0.20	0.29
MP MB 080 4_160		70	100	250	4000	6000	17'	12'	5.4	89	0.20	0.29
MP MB 080 4_175		70	100	250	4000	6000	17'	12'	5.4	89	0.22	0.31
MP MB 080 4_200		70	100	250	4000	6000	17'	12'	5.4	89	0.20	0.29
MP MB 080 4_210		70	100	250	4000	6000	17'	12'	5.4	89	0.20	0.29
MP MB 080 4_216		70	100	250	3200	4500	17'	12'	5.4	89	0.20	0.29
MP MB 080 4_250		70	100	250	4000	6000	17'	12'	5.4	89	0.19	0.28
MP MB 080 4_280		70	100	250	4000	6000	17'	12'	5.4	89	0.19	0.28
MP MB 080 4_350		70	100	250	4000	6000	17'	12'	5.4	89	0.19	0.28
MP MB 080 4_400		70	100	250	4000	6000	17'	12'	5.4	89	0.19	0.28
MP MB 080 4_500		70	100	250	4000	6000	17'	12'	5.4	89	0.19	0.28
MP MB 080 4_700		70	100	250	4000	6000	17'	12'	5.4	89	0.19	0.28
MP MB 080 4_1000		40	80	180	4000	6000	17'	12'	5.4	89	0.19	0.28

MP

MP 105

IS

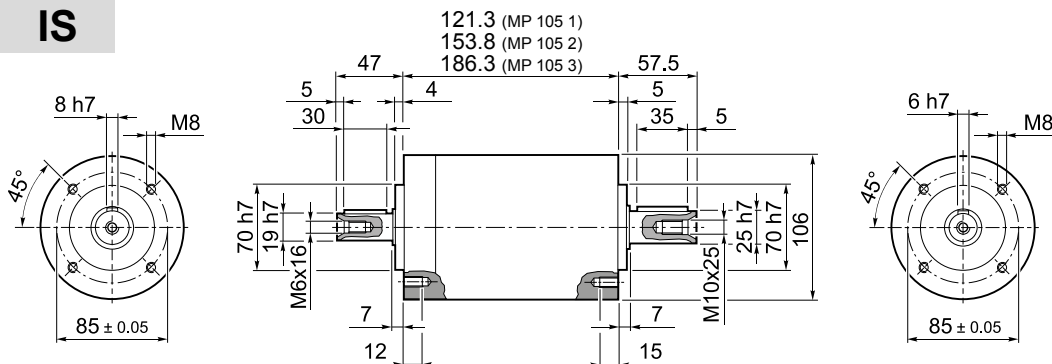

MP 105 1	6.5
MP 105 2	8.5
MP 105 3	10.5

50D ... 130A1

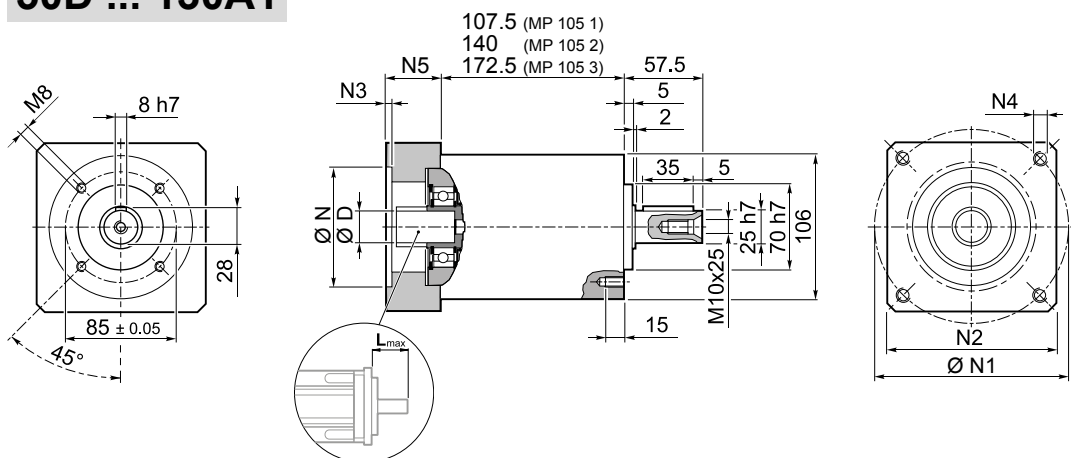

MP 105 1	6.5
MP 105 2	8.5
MP 105 3	10.5

MP

											N	N1	N2	N3	N4	N5	L _{max}	
50D	11	12	12.7	14	15	15.875	16	19	-	-	-	50	95	100	5	M6x14	28	40
55A	11	12	12.7	14	15	15.875	16	19	-	-	-	55	125.7	105	5	M6x16	28	40
60A2	11	12	12.7	14	15	15.875	16	19	-	-	-	60	75	100	6.5	M5x14	28	40
60AH2	11	12	12.7	14	15	15.875	16	19	-	-	-	60	75	100	4	6.5	33	40
60B1	11	12	12.7	14	15	15.875	16	19	-	-	-	60	85	100	6.5	M5x14	28	40
70A1	11	12	12.7	14	15	15.875	16	19	-	-	-	70	85	100	6.5	M6x14	28	40
70AH1	11	12	12.7	14	15	15.875	16	19	-	-	-	70	85	100	4	6.5	33	40
70B1	11	12	12.7	14	15	15.875	16	19	-	-	-	70	90	100	6.5	M5x12	28	40
80A1	11	12	12.7	14	15	15.875	16	19	-	-	-	80	100	100	6.5	M6x16	28	40
80AH1	11	12	12.7	14	15	15.875	16	19	-	-	-	80	100	100	4	6.5	33	40
95A	11	12	12.7	14	15	15.875	16	19	-	-	-	95	115	100	6.5	M8x18	28	40
95A1	11	12	12.7	14	15	15.875	16	19	22	24	-	95	115	100	6.5	M8x18	38	50
95B	11	12	12.7	14	15	15.875	16	19	-	-	-	95	130	115	6.5	M8x18	28	40
110A	11	12	12.7	14	15	15.875	16	19	-	-	-	110	130	115	6.5	M8x18	28	40
110A1	11	12	12.7	14	15	15.875	16	19	22	24	-	110	130	115	6.5	M8x20	38	50
110B	11	12	12.7	14	15	15.875	16	19	22	24	-	110	145	120	6.5	M8x20	38	50
110B1	11	12	12.7	14	15	15.875	16	19	22	24	28	110	145	120	6.5	M8x20	48	60
130A	11	12	12.7	14	15	15.875	16	19	22	24	-	130	165	140	6.5	M10x20	38	50
130A1	11	12	12.7	14	15	15.875	16	19	22	24	28	130	165	140	6.5	M10x25	48	60

Please contact us for other motor adapters and input shaft bore.

MP G 105

50D ... 130A1

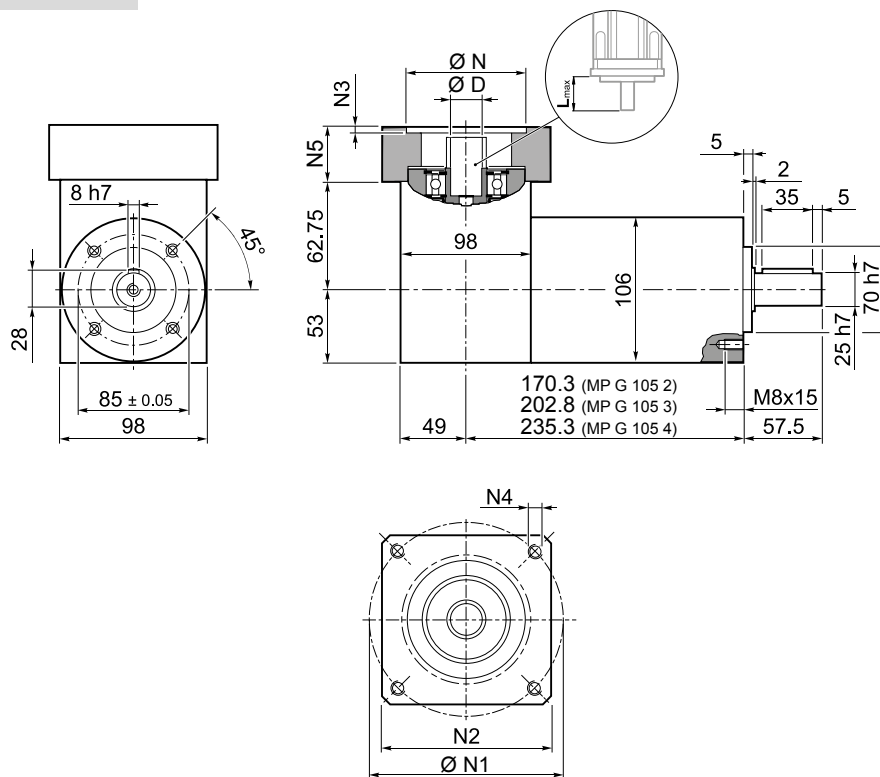

	
MP G 105 2	8.5
MP G 105 3	10.5
MP G 105 4	12.5

MP

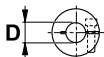
													N	N1	N2	N3	N4	N5	L _{max}
50D	11	12	12.7	14	15	15.875	16	19	-	-	-	-	50	95	100	5	M6x14	28	40
55A	11	12	12.7	14	15	15.875	16	19	-	-	-	-	55	125.7	105	5	M6x16	28	40
60A2	11	12	12.7	14	15	15.875	16	19	-	-	-	-	60	75	100	6.5	M5x14	28	40
60AH2	11	12	12.7	14	15	15.875	16	19	-	-	-	-	60	75	100	4	6.5	33	40
60B1	11	12	12.7	14	15	15.875	16	19	-	-	-	-	60	85	100	6.5	M5x14	28	40
70A1	11	12	12.7	14	15	15.875	16	19	-	-	-	-	70	85	100	6.5	M6x14	28	40
70AH1	11	12	12.7	14	15	15.875	16	19	-	-	-	-	70	85	100	4	6.5	33	40
70B1	11	12	12.7	14	15	15.875	16	19	-	-	-	-	70	90	100	6.5	M5x12	28	40
80A1	11	12	12.7	14	15	15.875	16	19	-	-	-	-	80	100	100	6.5	M6x16	28	40
80AH1	11	12	12.7	14	15	15.875	16	19	-	-	-	-	80	100	100	4	6.5	33	40
95A	11	12	12.7	14	15	15.875	16	19	-	-	-	-	95	115	100	6.5	M8x18	28	40
95A1	11	12	12.7	14	15	15.875	16	19	22	24	-	-	95	115	100	6.5	M8x18	38	50
95B	11	12	12.7	14	15	15.875	16	19	-	-	-	-	95	130	115	6.5	M8x18	28	40
110A	11	12	12.7	14	15	15.875	16	19	-	-	-	-	110	130	115	6.5	M8x18	28	40
110A1	11	12	12.7	14	15	15.875	16	19	22	24	-	-	110	130	115	6.5	M8x20	38	50
110B	11	12	12.7	14	15	15.875	16	19	22	24	-	-	110	145	120	6.5	M8x20	38	50
110B1	11	12	12.7	14	15	15.875	16	19	22	24	28	-	110	145	120	6.5	M8x20	48	60
130A	11	12	12.7	14	15	15.875	16	19	22	24	-	-	130	165	140	6.5	M10x20	38	50
130A1	11	12	12.7	14	15	15.875	16	19	22	24	28	32	130	165	140	6.5	M10x25	48	60

Please contact us for other motor adapters and input shaft bore.

MP MB 105

50D ... 130A1

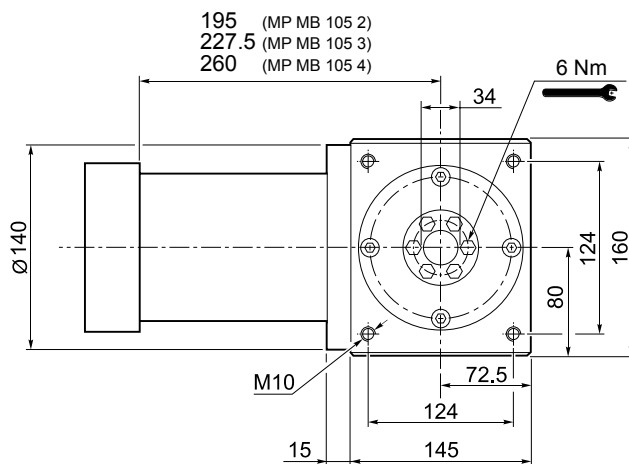
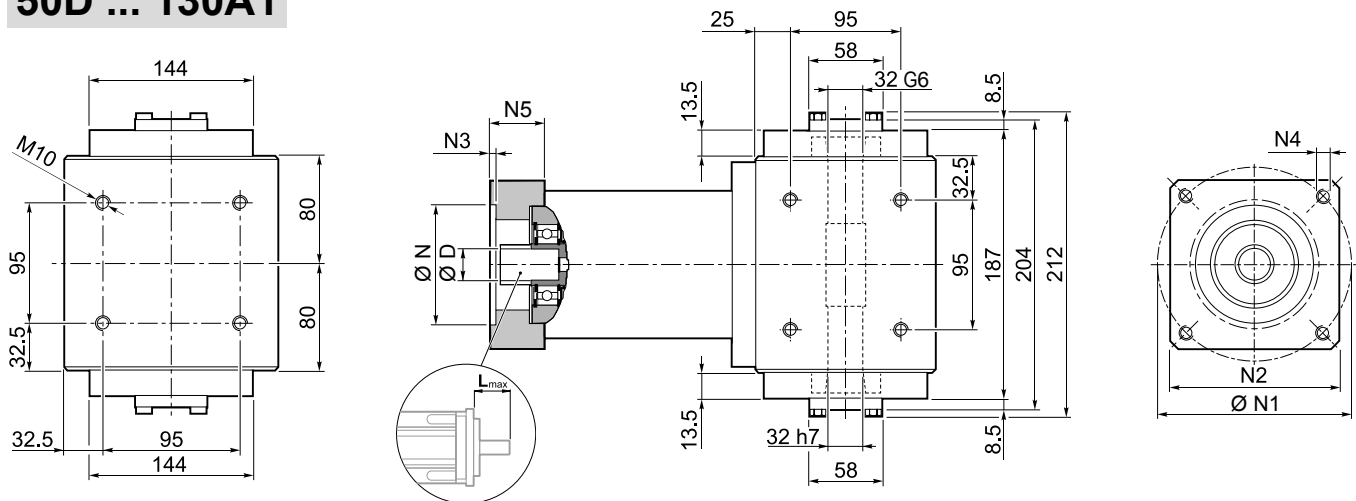

MP MB 105 2	32
MP MB 105 3	34
MP MB 105 4	36

MP

											N	N1	N2	N3	N4	N5	L _{max}	
50D	11	12	12.7	14	15	15.875	16	19	-	-	-	50	95	100	5	M6x14	28	40
55A	11	12	12.7	14	15	15.875	16	19	-	-	-	55	125.7	105	5	M6x16	28	40
60A2	11	12	12.7	14	15	15.875	16	19	-	-	-	60	75	100	6.5	M5x14	28	40
60AH2	11	12	12.7	14	15	15.875	16	19	-	-	-	60	75	100	4	6.5	33	40
60B1	11	12	12.7	14	15	15.875	16	19	-	-	-	60	85	100	6.5	M5x14	28	40
70A1	11	12	12.7	14	15	15.875	16	19	-	-	-	70	85	100	6.5	M6x14	28	40
70AH1	11	12	12.7	14	15	15.875	16	19	-	-	-	70	85	100	4	6.5	33	40
70B1	11	12	12.7	14	15	15.875	16	19	-	-	-	70	90	100	6.5	M5x12	28	40
80A1	11	12	12.7	14	15	15.875	16	19	-	-	-	80	100	100	6.5	M6x16	28	40
80AH1	11	12	12.7	14	15	15.875	16	19	-	-	-	80	100	100	4	6.5	33	40
95A	11	12	12.7	14	15	15.875	16	19	-	-	-	95	115	100	6.5	M8x18	28	40
95A1	11	12	12.7	14	15	15.875	16	19	22	24	-	95	115	100	6.5	M8x18	38	50
95B	11	12	12.7	14	15	15.875	16	19	-	-	-	95	130	115	6.5	M8x18	28	40
110A	11	12	12.7	14	15	15.875	16	19	-	-	-	110	130	115	6.5	M8x18	28	40
110A1	11	12	12.7	14	15	15.875	16	19	22	24	-	110	130	115	6.5	M8x20	38	50
110B	11	12	12.7	14	15	15.875	16	19	22	24	-	110	145	120	6.5	M8x20	38	50
110B1	11	12	12.7	14	15	15.875	16	19	22	24	28	110	145	120	6.5	M8x20	48	60
130A	11	12	12.7	14	15	15.875	16	19	22	24	-	130	165	140	6.5	M10x20	38	50
130A1	11	12	12.7	14	15	15.875	16	19	22	24	28	130	165	140	6.5	M10x25	48	60

Please contact us for other motor adapters and input shaft bore.

MP MB 105

FM

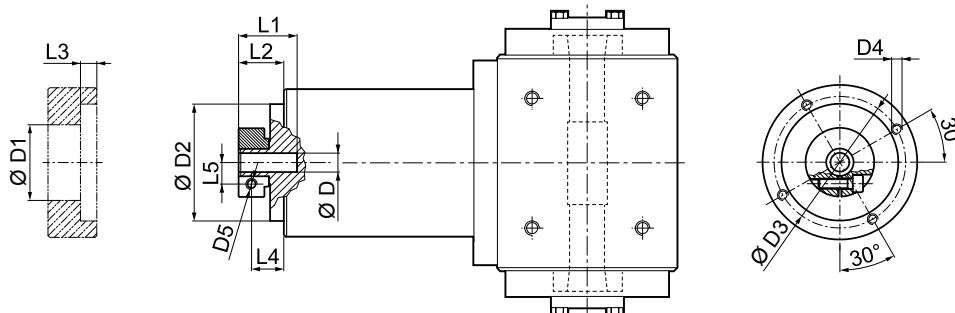

D				D1	D2	D3	D4	D5	L1	L2	L3	L4	L5
11	12	12.7	16	43	90	98	M6x15	M6	31.5	19.5	7.6	12	12.5
14	15	15.875	16	48	90	98	M6x15	M6	31.5	19.5	7.6	12	14.5
19				51	90	98	M6x15	M6	31.5	19.5	7.6	12	16.5
22	24			56.5	90	98	M6x15	M6	35	23	7.6	12	19
28				67	90	98	M6x15	M8	35	23	7.6	14	22.5
32				71	90	98	M6x15	M8	37	25	7.6	16	24.5

i	M _{n2} [Nm]	M _{a2} [Nm]	M _{p2} [Nm]	n ₁ [min ⁻¹]	n _{1 max} [min ⁻¹]	Ψ _S [arcmin]	Ψ _R [arcmin]	C _t [Nm/arcmin]	η %	J _G [kgcm ²]			
										D			
										11 ... 12.7	14 ... 19	22 - 24	28 - 32
MP MB 105 2_3	100	180	360	2500	3500	15'	10'	22.0	94	1.70	1.78	2.22	2.59
MP MB 105 2_4	140	210	450	2800	4500	15'	10'	22.0	94	0.99	1.06	1.51	1.87
MP MB 105 2_5	140	210	450	3000	4500	15'	10'	22.0	94	0.72	0.79	1.23	1.60
MP MB 105 2_6	140	210	450	3000	4500	15'	10'	22.0	94	0.36	0.43	0.88	1.24
MP MB 105 2_7	140	210	450	3500	5000	15'	10'	22.0	94	0.47	0.55	0.99	1.35
MP MB 105 2_10	100	180	360	3500	5000	15'	10'	22.0	94	0.33	0.41	0.85	1.21
MP MB 105 3_9	100	180	360	2500	3500	15'	10'	20.5	91	1.58	1.63	2.07	2.44
MP MB 105 3_12	170	250	600	2500	3500	15'	10'	20.5	91	1.52	1.59	2.03	2.40
MP MB 105 3_15	170	250	600	2500	3500	15'	10'	20.5	91	1.47	1.55	1.99	2.36
MP MB 105 3_16	170	250	600	2800	4500	15'	10'	20.5	91	0.87	0.95	1.39	1.76
MP MB 105 3_20	170	250	600	3000	4500	15'	10'	20.5	91	0.86	0.93	1.37	1.74
MP MB 105 3_25	170	250	600	3000	4500	15'	10'	20.5	91	0.63	0.71	1.15	1.51
MP MB 105 3_28	170	250	600	3500	5000	15'	10'	20.5	91	0.43	0.51	0.95	1.32
MP MB 105 3_30	100	180	360	3500	5000	15'	10'	20.5	91	0.32	0.40	0.84	1.20
MP MB 105 3_35	170	250	600	3500	5000	15'	10'	20.5	91	0.43	0.50	0.95	1.31
MP MB 105 3_36	140	210	450	3000	4500	15'	10'	20.5	91	0.32	0.39	0.84	1.20
MP MB 105 3_40	170	250	600	3500	5000	15'	10'	20.5	91	0.31	0.39	0.83	1.20
MP MB 105 3_50	170	250	600	3500	5000	15'	10'	20.5	91	0.31	0.39	0.83	1.19
MP MB 105 3_70	170	250	600	3500	5000	15'	10'	20.5	91	0.31	0.38	0.83	1.19
MP MB 105 3_100	100	180	360	3500	5000	15'	10'	20.5	91	0.31	0.38	0.83	1.19
MP MB 105 4_48	170	250	600	2800	4500	17'	12'	17.5	89	0.91	0.98	1.42	1.79
MP MB 105 4_64	170	250	600	2800	4500	17'	12'	17.5	89	0.87	0.94	1.38	1.75
MP MB 105 4_75	170	250	600	3000	4500	17'	12'	17.5	89	0.66	0.74	1.18	1.55
MP MB 105 4_80	170	250	600	2800	4500	17'	12'	17.5	89	0.86	0.94	1.38	1.75
MP MB 105 4_84	170	250	600	3500	5000	17'	12'	17.5	89	0.44	0.52	0.96	1.33
MP MB 105 4_90	100	180	360	3500	5000	17'	12'	17.5	89	0.32	0.39	0.84	1.20
MP MB 105 4_120	170	250	600	3500	5000	17'	12'	17.5	89	0.32	0.39	0.84	1.20
MP MB 105 4_125	170	250	600	3000	4500	17'	12'	17.5	89	0.63	0.70	1.15	1.51
MP MB 105 4_140	170	250	600	3500	5000	17'	12'	17.5	89	0.43	0.51	0.95	1.32
MP MB 105 4_150	170	250	600	3500	5000	17'	12'	17.5	89	0.32	0.39	0.84	1.20
MP MB 105 4_160	170	250	600	3500	5000	17'	12'	17.5	89	0.31	0.39	0.83	1.21
MP MB 105 4_175	170	250	600	3500	5000	17'	12'	17.5	89	0.43	0.50	0.95	1.31
MP MB 105 4_200	170	250	600	3500	5000	17'	12'	17.5	89	0.31	0.39	0.83	1.20
MP MB 105 4_210	170	250	600	3500	5000	17'	12'	17.5	89	0.32	0.39	0.84	1.20
MP MB 105 4_216	170	250	600	3000	4500	17'	12'	17.5	89	0.31	0.39	0.83	1.20
MP MB 105 4_250	170	250	600	3500	5000	17'	12'	17.5	89	0.31	0.39	0.83	1.19
MP MB 105 4_280	170	250	600	3500	5000	17'	12'	17.5	89	0.31	0.38	0.83	1.19
MP MB 105 4_350	170	250	600	3500	5000	17'	12'	17.5	89	0.31	0.38	0.83	1.19
MP MB 105 4_400	170	250	600	3500	5000	17'	12'	17.5	89	0.31	0.38	0.83	1.19
MP MB 105 4_500	170	250	600	3500	5000	17'	12'	17.5	89	0.31	0.38	0.83	1.19
MP MB 105 4_700	170	250	600	3500	5000	17'	12'	17.5	89	0.31	0.38	0.83	1.19
MP MB 105 4_1000	100	180	360	3500	5000	17'	12'	17.5	89	0.31	0.38	0.83	1.19

MP

MP 130

IS

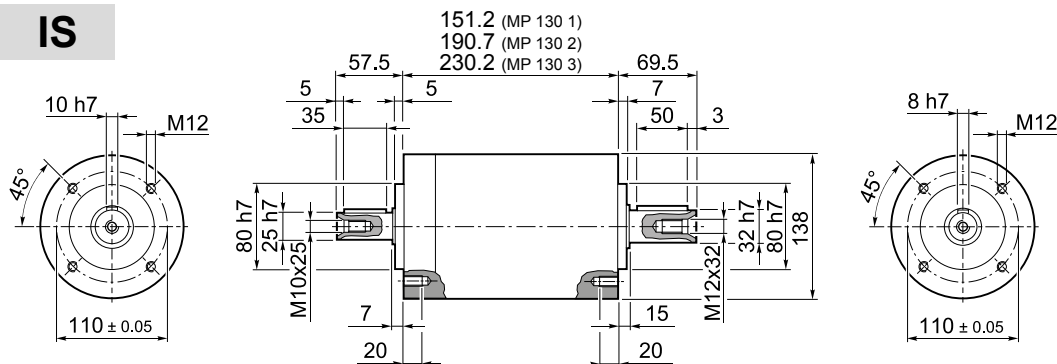

	
MP 130 1	12.0
MP 130 2	15.5
MP 130 3	18.5

55A1 ... 180A1

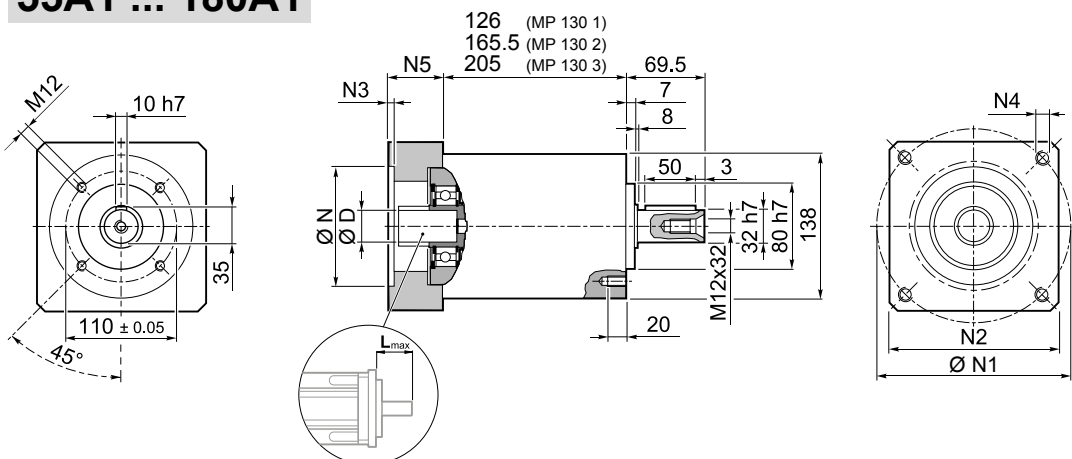

	
MP 130 1	12.0
MP 130 2	15.5
MP 130 3	18.5

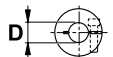
											N	N1	N2	N3	N4	N5	L _{max}
55A1	14	15.875	16	19	-	-	-	-	-	-	55.5	125.7	130	4	M6x15	39.5	50
80A2	14	15.875	16	19	-	-	-	-	-	-	80	100	130	4	M6x15	39.5	50
95A1	14	15.875	16	19	22	24	-	-	-	-	95	115	130	4	M8x20	39.5	50
110A1	14	15.875	16	19	22	24	-	-	-	-	110	130	130	4	M8x20	39.5	50
110B1	14	15.875	16	19	22	24	-	-	-	-	110	145	130	6.5	M8x20	49.5	60
114A0	14	15.875	16	19	22	24	-	-	-	-	114.3	200	170	5.5	M12x25	39.5	50
114A	14	15.875	16	19	22	24	28	32	35	38	114.3	200	170	5.5	M12x25	69.5	80
130A	14	15.875	16	19	22	24	-	-	-	-	130	165	140	4	M10x20	39.5	50
130A1	14	15.875	16	19	22	24	28	32	-	-	130	165	140	4	M10x20	49.5	60
180A	14	15.875	16	19	22	24	28	32	-	-	180	215	190	5.5	M14x25	49.5	60
180A1	14	15.875	16	19	22	24	28	32	35	38	180	215	190	5.5	M14x25	69.5	80

Please contact us for other motor adapters and input shaft bore.

MP 130

FM

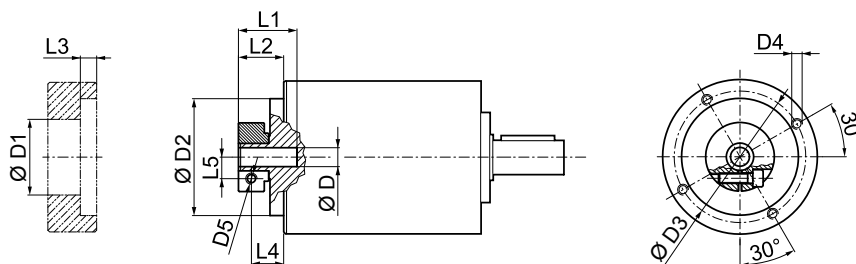

D			D1	D2	D3	D4	D5	L1	L2	L3	L4	L5
14	15.875	16	48	113	125.5	M8x15	M6	40	27.5	6	20	14.5
19			51	113	125.5	M8x15	M6	40	27.5	6	20	16.5
22	24		56.5	113	125.5	M8x15	M6	41	28.5	6	19.5	19
28			67	113	125.5	M8x15	M8	41	28.5	6	19.5	22.5
32			71	113	125.5	M8x15	M8	41	28.5	6	19.5	24.5
35			73	113	125.5	M8x15	M8	50	37.5	11.25	26	26
38			77.5	113	125.5	M8x15	M8	50	37.5	11.25	26	28

i	M _{n2} [Nm]	M _{a2} [Nm]	M _{p2} [Nm]	n ₁ [min ⁻¹]	n _{1 max} [min ⁻¹]	φ _S [arcmin]	φ _R [arcmin]	C _t [Nm/arcmin]	R _{1 max} [N]	R _{2 max} [N]	A _{2 max} [N]	η %	J _G [kgcm ²]			
													14 ... 19	22 - 24	28 - 32	35 - 38
MP 130 1_3	215	400	800	2100	3000	15'	10'	43.0	800	5500	6500	97	5.25	5.46	5.81	7.16
MP 130 1_4	380	600	1100	2400	3500	15'	10'	43.0	800	5500	6500	97	3.06	3.26	3.61	4.97
MP 130 1_5	380	600	1100	2900	3500	15'	10'	43.0	800	5500	6500	97	2.22	2.42	2.77	4.13
MP 130 1_6	380	600	1100	2900	3500	15'	10'	43.0	800	5500	6500	97	1.19	1.40	1.75	3.10
MP 130 1_7	380	600	1100	3200	4000	15'	10'	43.0	800	5500	6500	97	1.47	1.68	2.03	3.38
MP 130 1_10	215	400	800	3200	4000	15'	10'	43.0	800	5500	6500	97	1.04	1.25	1.60	2.95
MP 130 2_9	215	400	800	2100	3000	15'	10'	37.5	800	5500	6500	94	4.82	5.02	5.37	6.72
MP 130 2_12	450	700	1300	2100	3000	15'	10'	37.5	800	5500	6500	94	4.57	4.78	5.13	6.48
MP 130 2_15	450	700	1300	2100	3000	15'	10'	37.5	800	5500	6500	94	4.48	4.69	5.04	6.39
MP 130 2_16	450	700	1300	2400	3500	15'	10'	37.5	800	5500	6500	94	2.67	2.88	3.23	4.58
MP 130 2_20	450	700	1300	2900	3500	15'	10'	37.5	800	5500	6500	94	1.97	2.18	2.53	3.88
MP 130 2_25	450	700	1300	2900	3500	15'	10'	37.5	800	5500	6500	94	1.94	2.15	2.50	3.85
MP 130 2_28	450	700	1300	3200	4000	15'	10'	37.5	800	5500	6500	94	1.34	1.55	1.90	3.25
MP 130 2_30	215	400	800	3200	4000	15'	10'	37.5	800	5500	6500	94	1.00	1.21	1.56	2.91
MP 130 2_35	450	700	1300	3200	4000	15'	10'	37.5	800	5500	6500	94	1.33	1.53	1.88	3.24
MP 130 2_36	380	600	1100	2900	3500	15'	10'	37.5	800	5500	6500	94	1.05	1.26	1.61	2.96
MP 130 2_40	450	700	1300	3200	4000	15'	10'	37.5	800	5500	6500	94	0.98	1.19	1.54	2.89
MP 130 2_50	450	700	1300	3200	4000	15'	10'	37.5	800	5500	6500	94	0.97	1.18	1.53	2.88
MP 130 2_70	450	700	1300	3200	4000	15'	10'	37.5	800	5500	6500	94	0.96	1.17	1.52	2.87
MP 130 2_100	215	400	800	3200	4000	15'	10'	37.5	800	5500	6500	94	0.96	1.17	1.52	2.87
MP 130 3_48	450	700	1300	2400	3500	17'	12'	29.5	800	5500	6500	91	2.77	2.98	3.33	4.68
MP 130 3_64	450	700	1300	2400	3500	17'	12'	29.5	800	5500	6500	91	2.65	2.86	3.21	4.56
MP 130 3_75	450	700	1300	2900	3500	17'	12'	29.5	800	5500	6500	91	2.03	2.24	2.59	3.94
MP 130 3_80	450	700	1300	2400	3500	17'	12'	29.5	800	5500	6500	91	2.65	2.85	3.20	4.56
MP 130 3_84	450	700	1300	3200	4000	17'	12'	29.5	800	5500	6500	91	1.37	1.58	1.93	3.28
MP 130 3_90	215	400	800	3200	4000	17'	12'	29.5	800	5500	6500	91	1.00	1.20	1.55	2.91
MP 130 3_120	450	700	1300	3200	4000	17'	12'	29.5	800	5500	6500	91	0.99	1.20	1.55	2.90
MP 130 3_125	450	700	1300	2900	3500	17'	12'	29.5	800	5500	6500	91	1.93	2.13	2.48	3.84
MP 130 3_140	450	700	1300	3200	4000	17'	12'	29.5	800	5500	6500	91	1.34	1.54	1.89	3.25
MP 130 3_150	450	700	1300	3200	4000	17'	12'	29.5	800	5500	6500	91	0.99	1.20	1.55	2.90
MP 130 3_160	450	700	1300	3200	4000	17'	12'	29.5	800	5500	6500	91	0.98	1.18	1.53	2.89
MP 130 3_175	450	700	1300	3200	4000	17'	12'	29.5	800	5500	6500	91	1.32	1.53	1.88	3.23
MP 130 3_200	450	700	1300	3200	4000	17'	12'	29.5	800	5500	6500	91	0.97	1.18	1.53	2.88
MP 130 3_210	450	700	1300	3200	4000	17'	12'	29.5	800	5500	6500	91	0.99	1.20	1.55	2.90
MP 130 3_216	450	700	1300	2900	3500	17'	12'	29.5	800	5500	6500	91	1.05	1.26	1.61	2.96
MP 130 3_250	450	700	1300	3200	4000	17'	12'	29.5	800	5500	6500	91	0.97	1.18	1.53	2.88
MP 130 3_280	450	700	1300	3200	4000	17'	12'	29.5	800	5500	6500	91	0.96	1.17	1.52	2.87
MP 130 3_350	450	700	1300	3200	4000	17'	12'	29.5	800	5500	6500	91	0.96	1.17	1.52	2.87
MP 130 3_400	450	700	1300	3200	4000	17'	12'	29.5	800	5500	6500	91	0.96	1.17	1.52	2.87
MP 130 3_500	450	700	1300	3200	4000	17'	12'	29.5	800	5500	6500	91	0.96	1.17	1.52	2.87
MP 130 3_700	450	700	1300	3200	4000	17'	12'	29.5	800	5500	6500	91	0.96	1.17	1.52	2.87
MP 130 3_1000	215	400	800	3200	4000	17'	12'	29.5	800	5500	6500	91	0.96	1.17	1.52	2.87

MP

MP G 130

55A1 ... 180A1

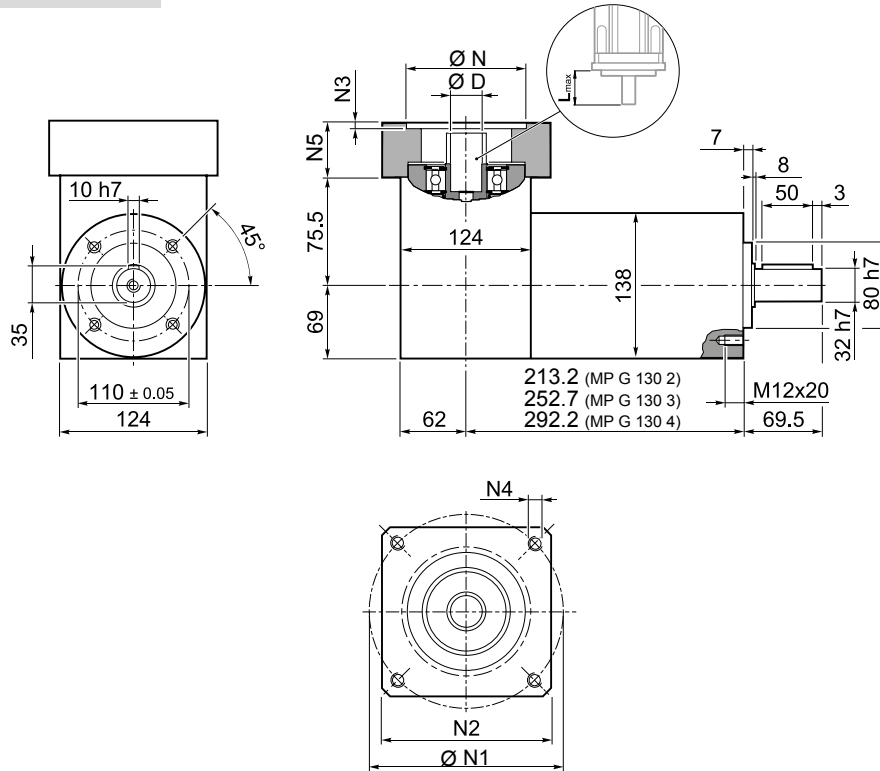

	
MP G 130 2	16.0
MP G 130 3	19.5
MP G 130 4	22.5

MP

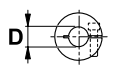
											N	N1	N2	N3	N4	N5	L _{max}
55A1	14	15.875	16	19	-	-	-	-	-	-	55.5	125.7	130	4	M6x15	39.5	50
80A2	14	15.875	16	19	-	-	-	-	-	-	80	100	130	4	M6x15	39.5	50
95A1	14	15.875	16	19	22	24	-	-	-	-	95	115	130	4	M8x20	39.5	50
110A1	14	15.875	16	19	22	24	-	-	-	-	110	130	130	4	M8x20	39.5	50
110B1	14	15.875	16	19	22	24	-	-	-	-	110	145	130	6.5	M8x20	49.5	60
114A0	14	15.875	16	19	22	24	-	-	-	-	114.3	200	170	5.5	M12x25	39.5	50
114A	14	15.875	16	19	22	24	28	32	35	38	114.3	200	170	5.5	M12x25	69.5	80
130A	14	15.875	16	19	22	24	-	-	-	-	130	165	140	4	M10x20	39.5	50
130A1	14	15.875	16	19	22	24	28	32	-	-	130	165	140	4	M10x20	49.5	60
180A	14	15.875	16	19	22	24	28	32	-	-	180	215	190	5.5	M14x25	49.5	60
180A1	14	15.875	16	19	22	24	28	32	35	38	180	215	190	5.5	M14x25	69.5	80

Please contact us for other motor adapters and input shaft bore.

MP G 130

FM

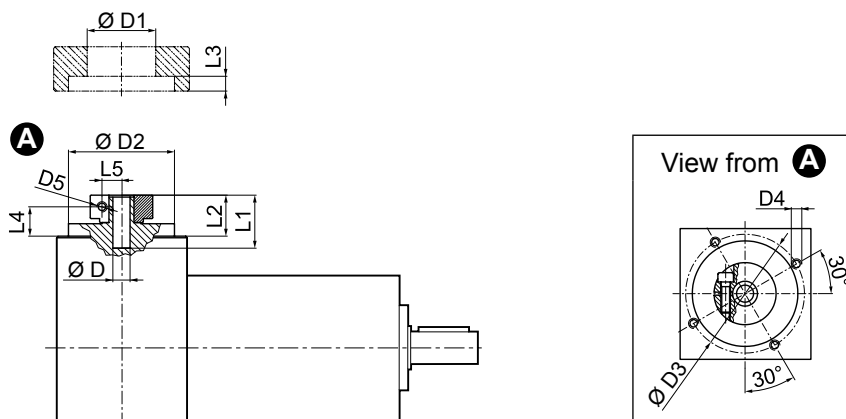

D		D1	D2	D3	D4	D5	L1	L2	L3	L4	L5	
14	15.875	16	48	113	125.5	M8x15	M6	40	27.5	6	20	14.5
19			51	113	125.5	M8x15	M6	40	27.5	6	20	16.5
22	24		56.5	113	125.5	M8x15	M6	41	28.5	6	19.5	19
28			67	113	125.5	M8x15	M8	41	28.5	6	19.5	22.5
32			71	113	125.5	M8x15	M8	41	28.5	6	19.5	24.5
35			73	113	125.5	M8x15	M8	50	37.5	11.25	26	26
38			77.5	113	125.5	M8x15	M8	50	37.5	11.25	26	28

i	M _{n 2} [Nm]	M _{a 2} [Nm]	M _{p 2} [Nm]	n ₁ [min ⁻¹]	n _{1 max} [min ⁻¹]	φ _S [arcmin]	φ _R [arcmin]	C _t [Nm/arcmin]	R _{2 max} [N]	A _{2 max} [N]	η %	J _G [kgcm ²]			
												14 ... 19	22 - 24	28 - 32	35 - 38
MP G 130 2_3	215	400	800	2100	3000	15'	10'	43.0	5500	6500	94	7.09	7.28	7.66	10.37
MP G 130 2_4	380	600	1100	2400	3500	15'	10'	43.0	5500	6500	94	4.90	5.08	5.46	8.18
MP G 130 2_5	380	600	1100	2900	3500	15'	10'	43.0	5500	6500	94	4.81	4.99	5.38	8.10
MP G 130 2_6	380	600	1100	2900	3500	15'	10'	43.0	5500	6500	94	4.45	4.64	5.03	7.73
MP G 130 2_7	380	600	1100	3200	4000	15'	10'	43.0	5500	6500	94	4.73	4.92	5.31	8.01
MP G 130 2_10	215	400	800	3200	4000	15'	10'	43.0	5500	6500	94	4.68	4.88	5.26	7.97
MP G 130 3_9	215	400	800	2100	3000	15'	10'	37.5	5500	6500	91	6.66	6.84	7.22	9.93
MP G 130 3_12	450	700	1300	2100	3000	15'	10'	37.5	5500	6500	91	6.25	6.45	6.84	9.54
MP G 130 3_15	450	700	1300	2100	3000	15'	10'	37.5	5500	6500	91	6.25	6.44	6.83	9.53
MP G 130 3_16	450	700	1300	2400	3500	15'	10'	37.5	5500	6500	91	4.51	4.70	5.08	7.79
MP G 130 3_20	450	700	1300	2900	3500	15'	10'	37.5	5500	6500	91	4.56	5.36	5.75	8.45
MP G 130 3_25	450	700	1300	2900	3500	15'	10'	37.5	5500	6500	91	5.13	4.72	5.11	7.82
MP G 130 3_28	450	700	1300	3200	4000	15'	10'	37.5	5500	6500	91	4.60	4.79	5.18	7.88
MP G 130 3_30	215	400	800	3200	4000	15'	10'	37.5	5500	6500	91	4.64	4.84	5.22	7.93
MP G 130 3_35	450	700	1300	3200	4000	15'	10'	37.5	5500	6500	91	4.92	5.10	5.49	8.20
MP G 130 3_36	380	600	1100	2900	3500	15'	10'	37.5	5500	6500	91	4.31	4.50	4.89	7.59
MP G 130 3_40	450	700	1300	3200	4000	15'	10'	37.5	5500	6500	91	4.77	4.96	5.35	8.05
MP G 130 3_50	450	700	1300	3200	4000	15'	10'	37.5	5500	6500	91	4.76	4.96	5.34	8.05
MP G 130 3_70	450	700	1300	3200	4000	15'	10'	37.5	5500	6500	91	4.60	4.80	5.18	7.89
MP G 130 3_100	215	400	800	3200	4000	15'	10'	37.5	5500	6500	91	4.60	4.80	5.18	7.89
MP G 130 4_48	450	700	1300	2400	3500	17'	12'	29.5	5500	6500	89	4.61	4.81	5.18	7.89
MP G 130 4_64	450	700	1300	2400	3500	17'	12'	29.5	5500	6500	89	4.49	4.68	5.06	7.77
MP G 130 4_75	450	700	1300	2900	3500	17'	12'	29.5	5500	6500	89	4.62	4.81	5.20	7.91
MP G 130 4_80	450	700	1300	2400	3500	17'	12'	29.5	5500	6500	89	4.49	4.67	5.05	7.77
MP G 130 4_84	450	700	1300	3200	4000	17'	12'	29.5	5500	6500	89	4.63	4.82	5.21	7.91
MP G 130 4_90	215	400	800	3200	4000	17'	12'	29.5	5500	6500	89	4.64	4.83	5.21	7.93
MP G 130 4_120	450	700	1300	3200	4000	17'	12'	29.5	5500	6500	89	4.63	4.83	5.21	7.92
MP G 130 4_125	450	700	1300	2900	3500	17'	12'	29.5	5500	6500	89	4.52	4.70	5.09	7.81
MP G 130 4_140	450	700	1300	3200	4000	17'	12'	29.5	5500	6500	89	4.60	4.78	5.17	7.88
MP G 130 4_150	450	700	1300	3200	4000	17'	12'	29.5	5500	6500	89	4.63	4.83	5.21	7.92
MP G 130 4_160	450	700	1300	3200	4000	17'	12'	29.5	5500	6500	89	4.62	4.81	5.19	7.91
MP G 130 4_175	450	700	1300	3200	4000	17'	12'	29.5	5500	6500	89	4.58	4.77	5.16	7.86
MP G 130 4_200	450	700	1300	3200	4000	17'	12'	29.5	5500	6500	89	4.61	4.81	5.19	7.90
MP G 130 4_210	450	700	1300	3200	4000	17'	12'	29.5	5500	6500	89	4.63	4.83	5.21	7.92
MP G 130 4_216	450	700	1300	2900	3500	17'	12'	29.5	5500	6500	89	4.31	4.50	4.89	7.59
MP G 130 4_250	450	700	1300	3200	4000	17'	12'	29.5	5500	6500	89	4.61	4.81	5.19	7.90
MP G 130 4_280	450	700	1300	3200	4000	17'	12'	29.5	5500	6500	89	4.60	4.80	5.18	7.89
MP G 130 4_350	450	700	1300	3200	4000	17'	12'	29.5	5500	6500	89	4.60	4.80	5.18	7.89
MP G 130 4_400	450	700	1300	3200	4000	17'	12'	29.5	5500	6500	89	4.60	4.80	5.18	7.89
MP G 130 4_500	450	700	1300	3200	4000	17'	12'	29.5	5500	6500	89	4.60	4.80	5.18	7.89
MP G 130 4_700	450	700	1300	3200	4000	17'	12'	29.5	5500	6500	89	4.60	4.80	5.18	7.89
MP G 130 4_1000	215	400	800	3200	4000	17'	12'	29.5	5500	6500	89	4.60	4.80	5.18	7.89

MP

MP MB 130

55A1 ... 180A1

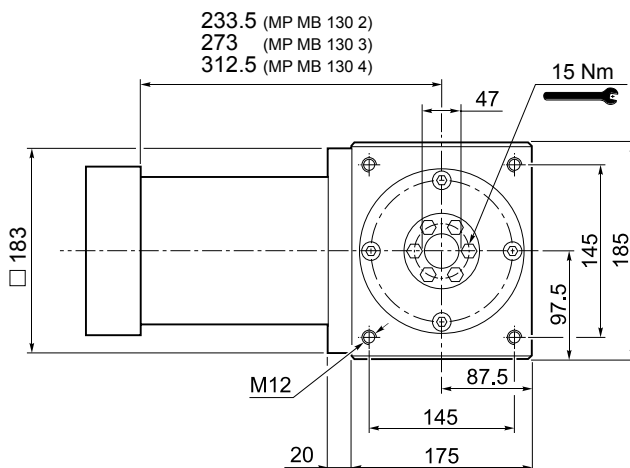
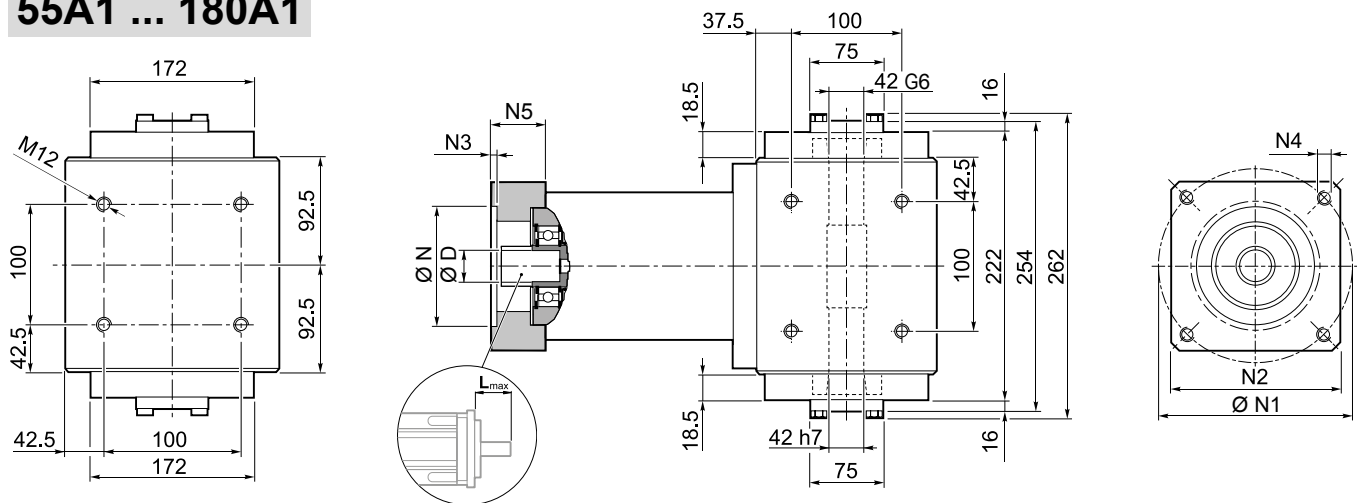

MP MB 130 2	54
MP MB 130 3	58
MP MB 130 4	61

											N	N1	N2	N3	N4	N5	L _{max}
	14	15.875	16	19	-	-	-	-	-	-							
55A1	14	15.875	16	19	-	-	-	-	-	-	55.5	125.7	130	4	M6x15	39.5	50
80A2	14	15.875	16	19	-	-	-	-	-	-	80	100	130	4	M6x15	39.5	50
95A1	14	15.875	16	19	22	24	-	-	-	-	95	115	130	4	M8x20	39.5	50
110A1	14	15.875	16	19	22	24	-	-	-	-	110	130	130	4	M8x20	39.5	50
110B1	14	15.875	16	19	22	24	-	-	-	-	110	145	130	6.5	M8x20	49.5	60
114A0	14	15.875	16	19	22	24	-	-	-	-	114.3	200	170	5.5	M12x25	39.5	50
114A	14	15.875	16	19	22	24	28	32	35	38	114.3	200	170	5.5	M12x25	69.5	80
130A	14	15.875	16	19	22	24	-	-	-	-	130	165	140	4	M10x20	39.5	50
130A1	14	15.875	16	19	22	24	28	32	-	-	130	165	140	4	M10x20	49.5	60
180A	14	15.875	16	19	22	24	28	32	-	-	180	215	190	5.5	M14x25	49.5	60
180A1	14	15.875	16	19	22	24	28	32	35	38	180	215	190	5.5	M14x25	69.5	80

Please contact us for other motor adapters and input shaft bore.

MP MB 130

FM

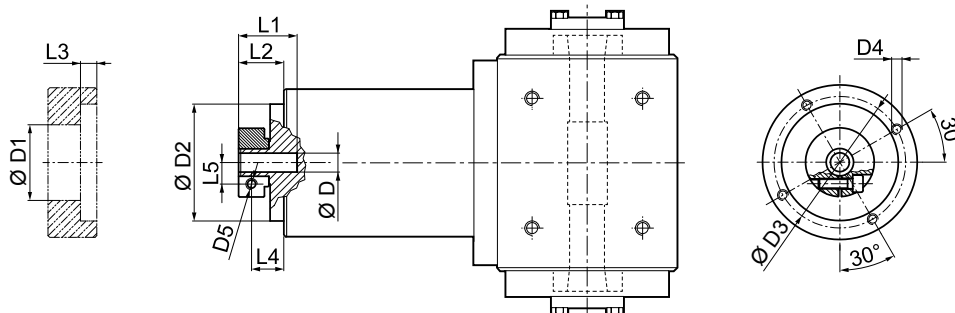

D	D1	D2	D3	D4	D5	L1	L2	L3	L4	L5
14	48	113	125.5	M8x15	M6	40	27.5	6	20	14.5
19	51	113	125.5	M8x15	M6	40	27.5	6	20	16.5
22	56.5	113	125.5	M8x15	M6	41	28.5	6	19.5	19
28	67	113	125.5	M8x15	M8	41	28.5	6	19.5	22.5
32	71	113	125.5	M8x15	M8	41	28.5	6	19.5	24.5
35	73	113	125.5	M8x15	M8	50	37.5	11.25	26	26
38	77.5	113	125.5	M8x15	M8	50	37.5	11.25	26	28

i	M _{n 2} [Nm]	M _{a 2} [Nm]	M _{p 2} [Nm]	n ₁ [min ⁻¹]	n _{1 max} [min ⁻¹]	φ _S [arcmin]	φ _R [arcmin]	C _t [Nm/arcmin]	η %	J _G [kgcm ²]			
										14 ... 19	22 - 24	28 - 32	35 - 38
MP MB 130 2_3	215	400	800	2100	3000	15'	10'	43.0	94	5.25	5.46	5.81	7.16
MP MB 130 2_4	380	600	1100	2400	3500	15'	10'	43.0	94	3.06	3.26	3.61	4.97
MP MB 130 2_5	380	600	1100	2900	3500	15'	10'	43.0	94	2.22	2.42	2.77	4.13
MP MB 130 2_6	380	600	1100	2900	3500	15'	10'	43.0	94	1.19	1.40	1.75	3.10
MP MB 130 2_7	380	600	1100	3200	4000	15'	10'	43.0	94	1.47	1.68	2.03	3.38
MP MB 130 2_10	215	400	800	3200	4000	15'	10'	43.0	94	1.04	1.25	1.60	2.95
MP MB 130 3_9	215	400	800	2100	3000	15'	10'	37.5	91	4.82	5.02	5.37	6.72
MP MB 130 3_12	450	700	1300	2100	3000	15'	10'	37.5	91	4.57	4.78	5.13	6.48
MP MB 130 3_15	450	700	1300	2100	3000	15'	10'	37.5	91	4.48	4.69	5.04	6.39
MP MB 130 3_16	450	700	1300	2400	3500	15'	10'	37.5	91	2.67	2.88	3.23	4.58
MP MB 130 3_20	450	700	1300	2900	3500	15'	10'	37.5	91	1.97	2.18	2.53	3.88
MP MB 130 3_25	450	700	1300	2900	3500	15'	10'	37.5	91	1.94	2.15	2.50	3.85
MP MB 130 3_28	450	700	1300	3200	4000	15'	10'	37.5	91	1.34	1.55	1.90	3.25
MP MB 130 3_30	215	400	800	3200	4000	15'	10'	37.5	91	1.00	1.21	1.56	2.91
MP MB 130 3_35	450	700	1300	3200	4000	15'	10'	37.5	91	1.33	1.53	1.88	3.24
MP MB 130 3_36	380	600	1100	2900	3500	15'	10'	37.5	91	1.05	1.26	1.61	2.96
MP MB 130 3_40	450	700	1300	3200	4000	15'	10'	37.5	91	0.98	1.19	1.54	2.89
MP MB 130 3_50	450	700	1300	3200	4000	15'	10'	37.5	91	0.97	1.18	1.53	2.88
MP MB 130 3_70	450	700	1300	3200	4000	15'	10'	37.5	91	0.96	1.17	1.52	2.87
MP MB 130 3_100	215	400	800	3200	4000	15'	10'	37.5	91	0.96	1.17	1.52	2.87
MP MB 130 4_48	450	700	1300	2400	3500	17'	12'	29.5	89	2.77	2.98	3.33	4.68
MP MB 130 4_64	450	700	1300	2400	3500	17'	12'	29.5	89	2.65	2.86	3.21	4.56
MP MB 130 4_75	450	700	1300	2900	3500	17'	12'	29.5	89	2.03	2.24	2.59	3.94
MP MB 130 4_80	450	700	1300	2400	3500	17'	12'	29.5	89	2.65	2.85	3.20	4.56
MP MB 130 4_84	450	700	1300	3200	4000	17'	12'	29.5	89	1.37	1.58	1.93	3.28
MP MB 130 4_90	215	400	800	3200	4000	17'	12'	29.5	89	1.00	1.20	1.55	2.91
MP MB 130 4_120	450	700	1300	3200	4000	17'	12'	29.5	89	0.99	1.20	1.55	2.90
MP MB 130 4_125	450	700	1300	2900	3500	17'	12'	29.5	89	1.93	2.13	2.48	3.84
MP MB 130 4_140	450	700	1300	3200	4000	17'	12'	29.5	89	1.34	1.54	1.89	3.25
MP MB 130 4_150	450	700	1300	3200	4000	17'	12'	29.5	89	0.99	1.20	1.55	2.90
MP MB 130 4_160	450	700	1300	3200	4000	17'	12'	29.5	89	0.98	1.18	1.53	2.89
MP MB 130 4_175	450	700	1300	3200	4000	17'	12'	29.5	89	1.32	1.53	1.88	3.23
MP MB 130 4_200	450	700	1300	3200	4000	17'	12'	29.5	89	0.97	1.18	1.53	2.88
MP MB 130 4_210	450	700	1300	3200	4000	17'	12'	29.5	89	0.99	1.20	1.55	2.90
MP MB 130 4_216	450	700	1300	2900	3500	17'	12'	29.5	89	1.05	1.26	1.61	2.96
MP MB 130 4_250	450	700	1300	3200	4000	17'	12'	29.5	89	0.97	1.18	1.53	2.88
MP MB 130 4_280	450	700	1300	3200	4000	17'	12'	29.5	89	0.96	1.17	1.52	2.87
MP MB 130 4_350	450	700	1300	3200	4000	17'	12'	29.5	89	0.96	1.17	1.52	2.87
MP MB 130 4_400	450	700	1300	3200	4000	17'	12'	29.5	89	0.96	1.17	1.52	2.87
MP MB 130 4_500	450	700	1300	3200	4000	17'	12'	29.5	89	0.96	1.17	1.52	2.87
MP MB 130 4_700	450	700	1300	3200	4000	17'	12'	29.5	89	0.96	1.17	1.52	2.87
MP MB 130 4_1000	215	400	800	3200	4000	17'	12'	29.5	89	0.96	1.17	1.52	2.87

MP

MP 160

IS

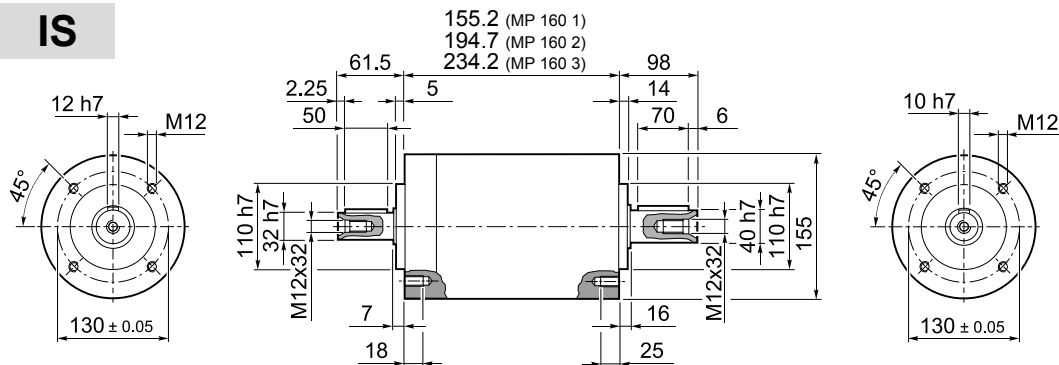

MP 160 1	17.0
MP 160 2	21
MP 160 3	28

55A1 ... 180A1

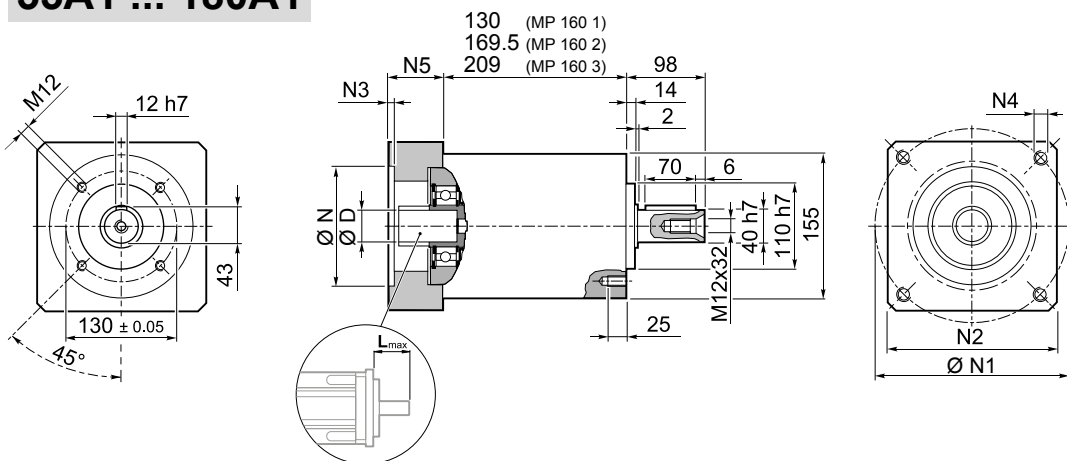

MP 160 1	17.0
MP 160 2	21
MP 160 3	28

											N	N1	N2	N3	N4	N5	L _{max}
55A1	14	15.875	16	19	-	-	-	-	-	-	55.5	125.7	140	5	M6x15	39.5	50
80A2	14	15.875	16	19	-	-	-	-	-	-	80	100	140	5	M6x15	39.5	50
95A1	14	15.875	16	19	22	24	-	-	-	-	95	115	140	5	M8x20	39.5	50
110A1	14	15.875	16	19	22	24	-	-	-	-	110	130	140	5	M8x20	39.5	50
110B1	14	15.875	16	19	22	24	-	-	-	-	110	145	140	6.5	M8x20	49.5	60
114A	14	15.875	16	19	22	24	28	32	35	38	114.3	200	170	6.5	M12x25	69.5	80
130A	14	15.875	16	19	22	24	-	-	-	-	130	165	140	5	M10x20	39.5	50
130A1	14	15.875	16	19	22	24	28	32	-	-	130	165	140	5	M10x20	49.5	60
180A	14	15.875	16	19	22	24	28	32	-	-	180	215	190	6.5	M14x25	49.5	60
180A1	14	15.875	16	19	22	24	28	32	35	38	180	215	190	6.5	M14x25	69.5	80

Please contact us for other motor adapters and input shaft bore.

MP 160

FM

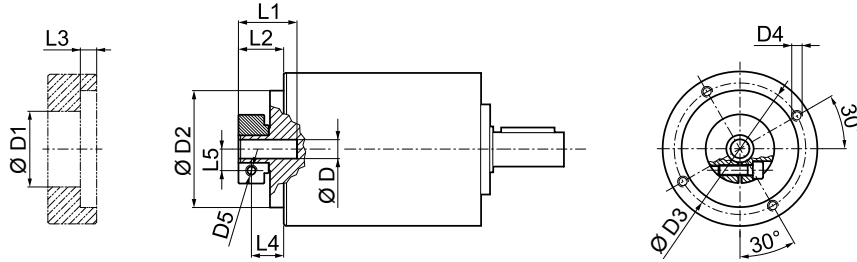

D		D1	D2	D3	D4	D5	L1	L2	L3	L4	L5	
14	15.875	16	48	130	142.5	M8x16	M6	40	27.5	6	20	14.5
19			51	130	142.5	M8x16	M6	40	27.5	6	20	16.5
22	24		56.5	130	142.5	M8x16	M6	41	28.5	6	19.5	19
28			67	130	142.5	M8x16	M8	41	28.5	6	19.5	22.5
32			71	130	142.5	M8x16	M8	41	28.5	6	19.5	24.5
35			73	130	142.5	M8x16	M8	50	37.5	11.25	26	26
38			77.5	130	142.5	M8x16	M8	50	37.5	11.25	26	28

i	M _{n 2} [Nm]	M _{a 2} [Nm]	M _{p 2} [Nm]	n ₁ [min ⁻¹]	n _{1 max} [min ⁻¹]	φ _S [arcmin]	φ _R [arcmin]	C _t [Nm/arcmin]	R _{1 max} [N]	R _{2 max} [N]	A _{2 max} [N]	η %	J _e [kgcm ²]			
													14 ... 19	22 - 24	28 - 32	35 - 38
MP 160 1_3	350	660	1200	1900	3000	15'	10'	90	1200	6500	7500	97	8.39	8.60	8.95	10.30
MP 160 1_4	500	750	1400	2200	3500	15'	10'	90	1200	6500	7500	97	4.68	4.89	5.24	6.59
MP 160 1_5	500	750	1400	2500	3500	15'	10'	90	1200	6500	7500	97	3.28	3.49	3.84	5.19
MP 160 1_6	500	750	1400	2500	3500	15'	10'	90	1200	6500	7500	97	1.32	1.53	1.88	3.23
MP 160 1_7	500	750	1400	3000	4000	15'	10'	90	1200	6500	7500	97	2.03	2.24	2.59	3.94
MP 160 1_10	350	660	1200	3000	4000	15'	10'	90	1200	6500	7500	97	1.33	1.53	1.88	3.24
MP 160 2_9	350	660	1200	1900	3000	15'	10'	83	1200	6500	7500	94	7.51	7.72	8.07	9.42
MP 160 2_12	700	950	1800	1900	3000	15'	10'	83	1200	6500	7500	94	7.10	7.30	7.65	9.01
MP 160 2_15	700	950	1800	1900	3000	15'	10'	83	1200	6500	7500	94	6.94	7.15	7.50	8.85
MP 160 2_16	700	950	1800	2200	3500	15'	10'	83	1200	6500	7500	94	3.95	4.16	4.51	5.86
MP 160 2_20	700	950	1800	2500	3500	15'	10'	83	1200	6500	7500	94	2.82	3.02	3.37	4.73
MP 160 2_25	700	950	1800	2500	3500	15'	10'	83	1200	6500	7500	94	2.76	2.97	3.32	4.67
MP 160 2_28	700	950	1800	3000	4000	15'	10'	83	1200	6500	7500	94	1.79	2.00	2.35	3.70
MP 160 2_30	350	660	1200	3000	4000	15'	10'	83	1200	6500	7500	94	1.25	1.46	1.81	3.16
MP 160 2_35	700	950	1800	3000	4000	15'	10'	83	1200	6500	7500	94	1.77	1.97	2.32	3.68
MP 160 2_36	500	750	1400	2500	3500	15'	10'	83	1200	6500	7500	94	1.06	1.27	1.62	2.97
MP 160 2_40	700	950	1800	3000	4000	15'	10'	83	1200	6500	7500	94	1.21	1.42	1.77	3.12
MP 160 2_50	700	950	1800	3000	4000	15'	10'	83	1200	6500	7500	94	1.20	1.40	1.75	3.11
MP 160 2_70	700	950	1800	3000	4000	15'	10'	83	1200	6500	7500	94	1.18	1.39	1.74	3.09
MP 160 2_100	350	660	1200	3000	4000	15'	10'	83	1200	6500	7500	94	1.18	1.38	1.73	3.09
MP 160 3_48	700	950	1800	2200	3500	17'	12'	60	1200	6500	7500	91	4.10	4.31	4.66	6.01
MP 160 3_64	700	950	1800	2200	3500	17'	12'	60	1200	6500	7500	91	3.90	4.11	4.46	5.81
MP 160 3_75	700	950	1800	2500	3500	17'	12'	60	1200	6500	7500	91	2.91	3.11	3.46	4.82
MP 160 3_80	700	950	1800	2200	3500	17'	12'	60	1200	6500	7500	91	3.90	4.11	4.46	5.81
MP 160 3_84	700	950	1800	3000	4000	17'	12'	60	1200	6500	7500	91	1.84	2.05	2.40	3.75
MP 160 3_90	350	660	1200	3000	4000	17'	12'	60	1200	6500	7500	91	1.24	1.45	1.80	3.15
MP 160 3_120	700	950	1800	3000	4000	17'	12'	60	1200	6500	7500	91	1.23	1.44	1.79	3.14
MP 160 3_125	700	950	1800	2500	3500	17'	12'	60	1200	6500	7500	91	2.74	2.95	3.30	4.65
MP 160 3_140	700	950	1800	3000	4000	17'	12'	60	1200	6500	7500	91	1.78	1.98	2.33	3.69
MP 160 3_150	700	950	1800	3000	4000	17'	12'	60	1200	6500	7500	91	1.23	1.44	1.79	3.14
MP 160 3_160	700	950	1800	3000	4000	17'	12'	60	1200	6500	7500	91	1.20	1.41	1.76	3.11
MP 160 3_175	700	950	1800	3000	4000	17'	12'	60	1200	6500	7500	91	1.76	1.96	2.31	3.67
MP 160 3_200	700	950	1800	3000	4000	17'	12'	60	1200	6500	7500	91	1.20	1.41	1.76	3.11
MP 160 3_210	700	950	1800	3000	4000	17'	12'	60	1200	6500	7500	91	1.23	1.44	1.79	3.14
MP 160 3_250	700	950	1800	3000	4000	17'	12'	60	1200	6500	7500	91	1.19	1.40	1.75	3.10
MP 160 3_280	700	950	1800	3000	4000	17'	12'	60	1200	6500	7500	91	1.18	1.39	1.74	3.09
MP 160 3_350	700	950	1800	3000	4000	17'	12'	60	1200	6500	7500	91	1.18	1.39	1.74	3.09
MP 160 3_400	700	950	1800	3000	4000	17'	12'	60	1200	6500	7500	91	1.18	1.38	1.73	3.09
MP 160 3_500	700	950	1800	3000	4000	17'	12'	60	1200	6500	7500	91	1.18	1.38	1.73	3.09
MP 160 3_700	700	950	1800	3000	4000	17'	12'	60	1200	6500	7500	91	1.18	1.38	1.73	3.09
MP 160 3_1000	350	660	1200	3000	4000	17'	12'	60	1200	6500	7500	91	1.18	1.38	1.73	3.09

MP

S-M-BOR-NL-CAFS-001-V01

MP G 160

55A1 ... 180A1

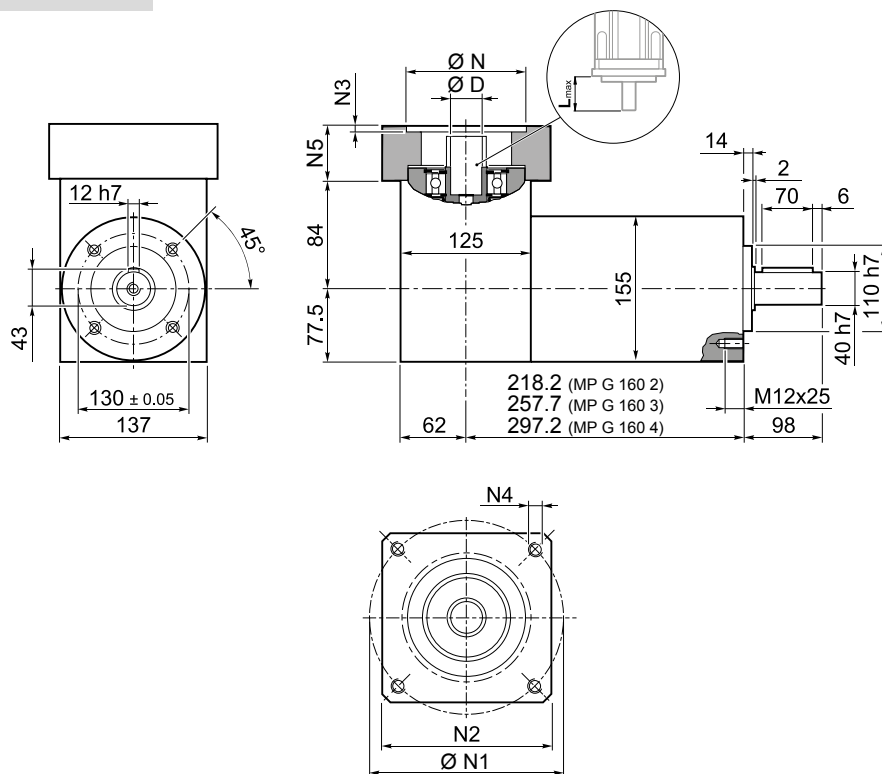

MP G 160 2	24
MP G 160 3	28
MP G 160 4	34

MP

											N	N1	N2	N3	N4	N5	L _{max}
55A1	14	15.875	16	19	-	-	-	-	-	-	55.5	125.7	140	5	M6x15	39.5	50
80A2	14	15.875	16	19	-	-	-	-	-	-	80	100	140	5	M6x15	39.5	50
95A1	14	15.875	16	19	22	24	-	-	-	-	95	115	140	5	M8x20	39.5	50
110A1	14	15.875	16	19	22	24	-	-	-	-	110	130	140	5	M8x20	39.5	50
110B1	14	15.875	16	19	22	24	-	-	-	-	110	145	140	6.5	M8x20	49.5	60
114A	14	15.875	16	19	22	24	28	32	35	38	114.3	200	170	6.5	M12x25	69.5	80
130A	14	15.875	16	19	22	24	-	-	-	-	130	165	140	5	M10x20	39.5	50
130A1	14	15.875	16	19	22	24	28	32	-	-	130	165	140	5	M10x20	49.5	60
180A	14	15.875	16	19	22	24	28	32	-	-	180	215	190	6.5	M14x25	49.5	60
180A1	14	15.875	16	19	22	24	28	32	35	38	180	215	190	6.5	M14x25	69.5	80

Please contact us for other motor adapters and input shaft bore.

MP G 160

FM

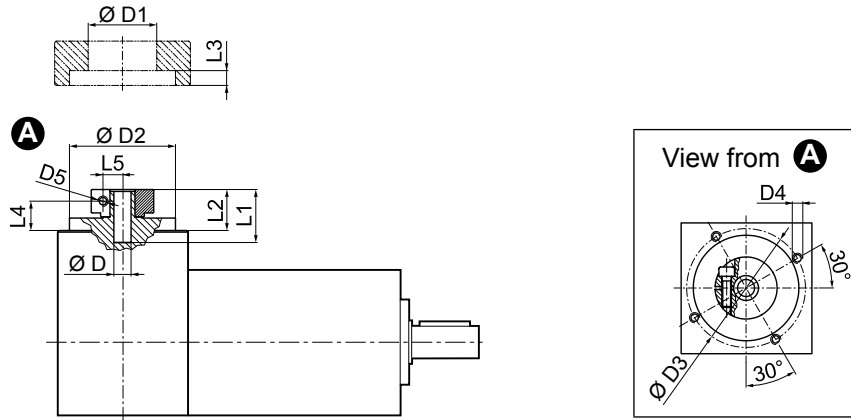

$\varnothing D$	$\varnothing D1$	$\varnothing D2$	$\varnothing D3$	$\varnothing D4$	$\varnothing D5$	$L1$	$L2$	$L3$	$L4$	$L5$
14	48	113	125.5	M8x15	M6	40	27.5	6	20	14.5
19	51	113	125.5	M8x15	M6	40	27.5	6	20	16.5
22	56.5	113	125.5	M8x15	M6	41	28.5	6	19.5	19
28	67	113	125.5	M8x15	M8	41	28.5	6	19.5	22.5
32	71	113	125.5	M8x15	M8	41	28.5	6	19.5	24.5
35	73	113	125.5	M8x15	M8	50	37.5	11.25	26	26
38	77.5	113	125.5	M8x15	M8	50	37.5	11.25	26	28

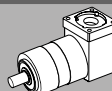
	$M_n 2$	$M_a 2$	$M_p 2$	n_1	$n_{1 \max}$	φ_S	φ_R	C_t	$R_{2 \max}$	$A_{2 \max}$	η	J_G [kgcm ²]			
												$\varnothing D$	14 ... 19	22 - 24	28 - 32
MP G 160 2_3	350	660	1200	1900	3000	15'	10'	90	6500	7500	94	10.23	10.42	10.80	13.51
MP G 160 2_4	500	750	1400	2200	3500	15'	10'	90	6500	7500	94	6.52	6.71	7.09	9.80
MP G 160 2_5	500	750	1400	2500	3500	15'	10'	90	6500	7500	94	5.87	6.06	6.45	9.16
MP G 160 2_6	500	750	1400	2500	3500	15'	10'	90	6500	7500	94	4.58	4.77	5.16	7.86
MP G 160 2_7	500	750	1400	3000	4000	15'	10'	90	6500	7500	94	5.29	5.48	5.87	8.57
MP G 160 2_10	350	660	1200	3000	4000	15'	10'	90	6500	7500	94	4.97	5.16	5.54	8.25
MP G 160 3_9	350	660	1200	1900	3000	15'	10'	83	6500	7500	91	9.35	9.54	9.92	12.63
MP G 160 3_12	700	950	1800	1900	3000	15'	10'	83	6500	7500	91	8.78	8.97	9.36	12.07
MP G 160 3_15	700	950	1800	1900	3000	15'	10'	83	6500	7500	91	8.71	8.90	9.29	11.99
MP G 160 3_16	700	950	1800	2200	3500	15'	10'	83	6500	7500	91	5.79	5.98	6.36	9.07
MP G 160 3_20	700	950	1800	2500	3500	15'	10'	83	6500	7500	91	5.41	6.20	6.59	9.30
MP G 160 3_25	700	950	1800	2500	3500	15'	10'	83	6500	7500	91	5.95	5.54	5.93	8.64
MP G 160 3_28	700	950	1800	3000	4000	15'	10'	83	6500	7500	91	5.05	5.24	5.63	8.33
MP G 160 3_30	350	660	1200	3000	4000	15'	10'	83	6500	7500	91	4.89	5.09	5.47	8.18
MP G 160 3_35	700	950	1800	3000	4000	15'	10'	83	6500	7500	91	5.36	5.54	5.93	8.64
MP G 160 3_36	500	750	1400	2500	3500	15'	10'	83	6500	7500	91	4.32	4.51	4.90	7.60
MP G 160 3_40	700	950	1800	3000	4000	15'	10'	83	6500	7500	91	5.00	5.19	5.58	8.28
MP G 160 3_50	700	950	1800	3000	4000	15'	10'	83	6500	7500	91	4.99	5.18	5.56	8.27
MP G 160 3_70	700	950	1800	3000	4000	15'	10'	83	6500	7500	91	4.82	5.02	5.40	8.11
MP G 160 3_100	350	660	1200	3000	4000	15'	10'	83	6500	7500	91	4.82	5.01	5.39	8.10
MP G 160 4_48	700	950	1800	2200	3500	17'	12'	60	6500	7500	89	5.94	6.13	6.53	9.22
MP G 160 4_64	700	950	1800	2200	3500	17'	12'	60	6500	7500	89	5.74	5.93	6.31	9.02
MP G 160 4_75	700	950	1800	2500	3500	17'	12'	60	6500	7500	89	5.50	5.68	6.07	8.79
MP G 160 4_80	700	950	1800	2200	3500	17'	12'	60	6500	7500	89	5.74	5.93	6.31	9.02
MP G 160 4_84	700	950	1800	3000	4000	17'	12'	60	6500	7500	89	5.10	5.29	5.68	8.38
MP G 160 4_90	350	660	1200	3000	4000	17'	12'	60	6500	7500	89	4.88	5.08	5.46	8.17
MP G 160 4_120	700	950	1800	3000	4000	17'	12'	60	6500	7500	89	4.87	5.07	5.45	8.16
MP G 160 4_125	700	950	1800	2500	3500	17'	12'	60	6500	7500	89	5.33	5.52	5.91	8.62
MP G 160 4_140	700	950	1800	3000	4000	17'	12'	60	6500	7500	89	5.04	5.22	5.61	8.32
MP G 160 4_150	700	950	1800	3000	4000	17'	12'	60	6500	7500	89	4.87	5.07	5.45	8.16
MP G 160 4_160	700	950	1800	3000	4000	17'	12'	60	6500	7500	89	4.84	5.04	5.42	8.13
MP G 160 4_175	700	950	1800	3000	4000	17'	12'	60	6500	7500	89	5.02	5.20	5.59	8.30
MP G 160 4_200	700	950	1800	3000	4000	17'	12'	60	6500	7500	89	4.84	5.04	5.42	8.13
MP G 160 4_210	700	950	1800	3000	4000	17'	12'	60	6500	7500	89	4.87	5.07	5.45	8.16
MP G 160 4_250	700	950	1800	3000	4000	17'	12'	60	6500	7500	89	4.83	5.03	5.41	8.12
MP G 160 4_280	700	950	1800	3000	4000	17'	12'	60	6500	7500	89	4.82	5.02	5.40	8.11
MP G 160 4_350	700	950	1800	3000	4000	17'	12'	60	6500	7500	89	4.82	2.05	5.40	8.11
MP G 160 4_400	700	950	1800	3000	4000	17'	12'	60	6500	7500	89	4.82	5.01	5.39	8.11
MP G 160 4_500	700	950	1800	3000	4000	17'	12'	60	6500	7500	89	4.82	5.01	5.39	8.11
MP G 160 4_700	700	950	1800	3000	4000	17'	12'	60	6500	7500	89	4.82	5.01	5.39	8.11
MP G 160 4_1000	350	660	1200	3000	4000	17'	12'	60	6500	7500	89	4.82	5.01	5.39	8.11

S-M-BOR-NL-CAFS-001-V01

MP

MP MB 160

55A1 ... 180A1

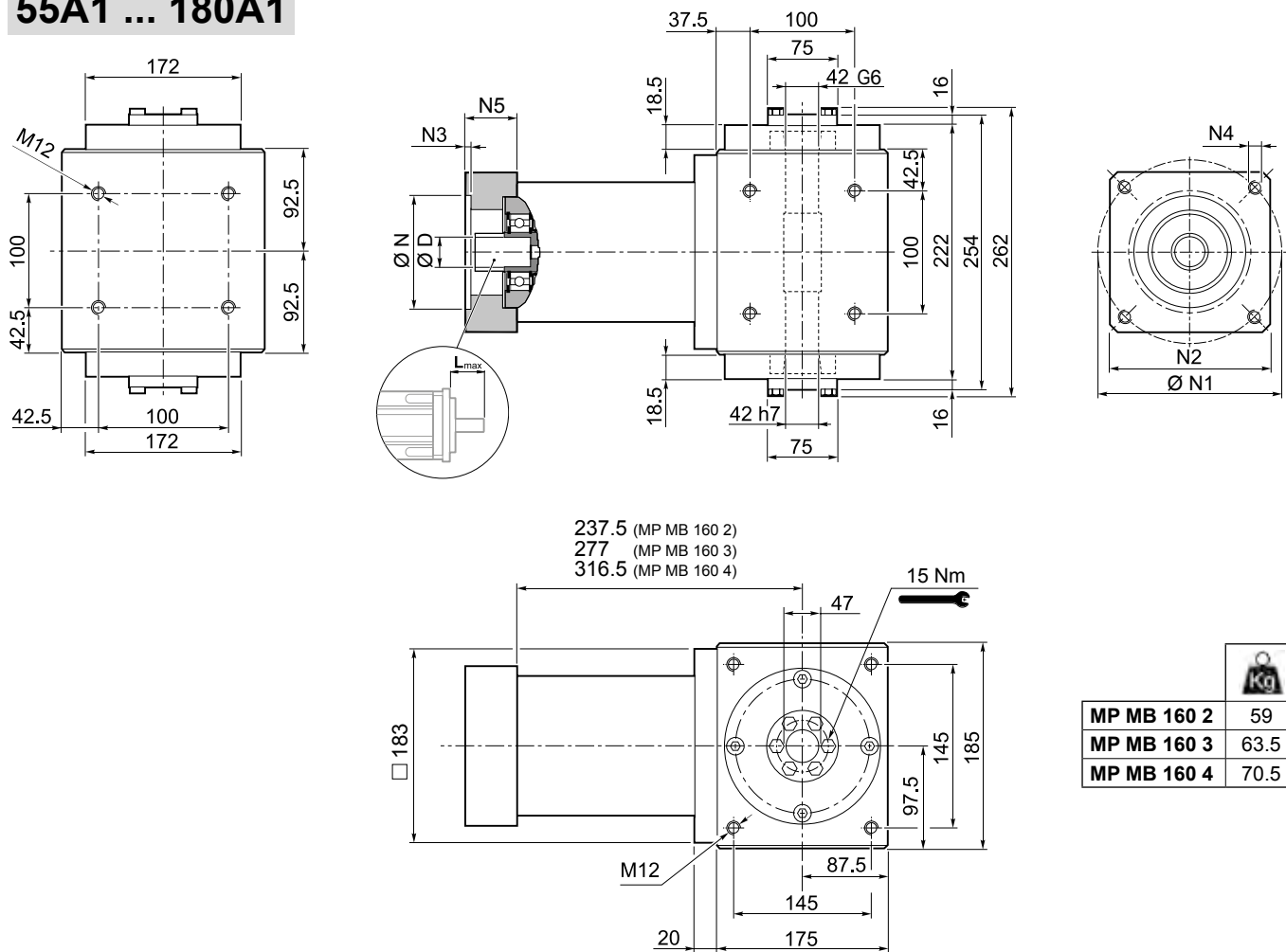

MP MB 160 2	59
MP MB 160 3	63.5
MP MB 160 4	70.5

MP

											N	N1	N2	N3	N4	N5	L _{max}
55A1	14	15.875	16	19	-	-	-	-	-	-	55.5	125.7	140	5	M6x15	39.5	50
80A2	14	15.875	16	19	-	-	-	-	-	-	80	100	140	5	M6x15	39.5	50
95A1	14	15.875	16	19	22	24	-	-	-	-	95	115	140	5	M8x20	39.5	50
110A1	14	15.875	16	19	22	24	-	-	-	-	110	130	140	5	M8x20	39.5	50
110B1	14	15.875	16	19	22	24	-	-	-	-	110	145	140	6.5	M8x20	49.5	60
114A	14	15.875	16	19	22	24	28	32	35	38	114.3	200	170	6.5	M12x25	69.5	80
130A	14	15.875	16	19	22	24	-	-	-	-	130	165	140	5	M10x20	39.5	50
130A1	14	15.875	16	19	22	24	28	32	-	-	130	165	140	5	M10x20	49.5	60
180A	14	15.875	16	19	22	24	28	32	-	-	180	215	190	6.5	M14x25	49.5	60
180A1	14	15.875	16	19	22	24	28	32	35	38	180	215	190	6.5	M14x25	69.5	80

Please contact us for other motor adapters and input shaft bore.

MP MB 160

FM

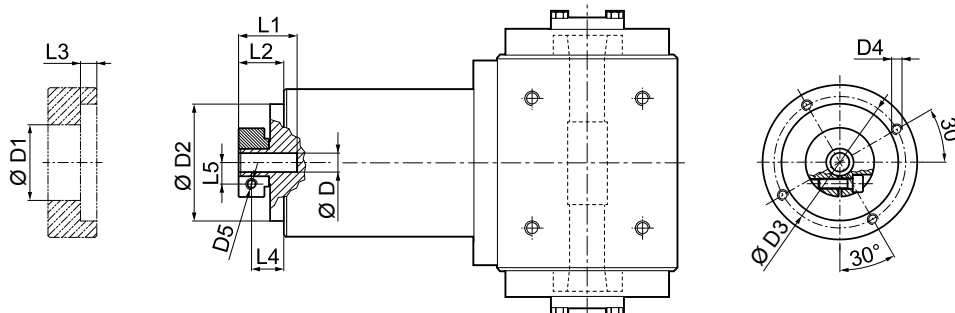

$\frac{D}{i}$	$\frac{D}{i}$	$\frac{D}{i}$	D1	D2	D3	D4	D5	L1	L2	L3	L4	L5
14	15.875	16	48	130	142.5	M8x16	M6	40	27.5	6	20	14.5
19			51	130	142.5	M8x16	M6	40	27.5	6	20	16.5
22	24		56.5	130	142.5	M8x16	M6	41	28.5	6	19.5	19
28			67	130	142.5	M8x16	M8	41	28.5	6	19.5	22.5
32			71	130	142.5	M8x16	M8	41	28.5	6	19.5	24.5
35			73	130	142.5	M8x16	M8	50	37.5	11.25	26	26
38			77.5	130	142.5	M8x16	M8	50	37.5	11.25	26	28

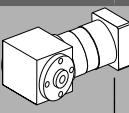
	M_{n2}	M_{a2}	M_{p2}	n_1	n_{1max}	φ_S	φ_R	C_t	η	J_G [kgcm ²]			
										14 ... 19	22 - 24	28 - 32	35 - 38
MP MB 160 2_3	350	660	1200	1900	3000	15'	10'	90	94	8.39	8.60	8.95	10.30
MP MB 160 2_4	500	750	1400	2200	3500	15'	10'	90	94	4.68	4.89	5.24	6.59
MP MB 160 2_5	500	750	1400	2500	3500	15'	10'	90	94	3.28	3.49	3.84	5.19
MP MB 160 2_6	500	750	1400	2500	3500	15'	10'	90	94	1.32	1.53	1.88	3.23
MP MB 160 2_7	500	750	1400	3000	4000	15'	10'	90	94	2.03	2.24	2.59	3.94
MP MB 160 2_10	350	660	1200	3000	4000	15'	10'	90	94	1.33	1.53	1.88	3.24
MP MB 160 3_9	350	660	1200	1900	3000	15'	10'	83	91	7.51	7.72	8.07	9.42
MP MB 160 3_12	700	950	1800	1900	3000	15'	10'	83	91	7.10	7.30	7.65	9.01
MP MB 160 3_15	700	950	1800	1900	3000	15'	10'	83	91	6.94	7.15	7.50	8.85
MP MB 160 3_16	700	950	1800	2200	3500	15'	10'	83	91	3.95	4.16	4.51	5.86
MP MB 160 3_20	700	950	1800	2500	3500	15'	10'	83	91	2.82	3.02	3.37	4.73
MP MB 160 3_25	700	950	1800	2500	3500	15'	10'	83	91	2.76	2.97	3.32	4.67
MP MB 160 3_28	700	950	1800	3000	4000	15'	10'	83	91	1.79	2.00	2.35	3.70
MP MB 160 3_30	350	660	1200	3000	4000	15'	10'	83	91	1.25	1.46	1.81	3.16
MP MB 160 3_35	700	950	1800	3000	4000	15'	10'	83	91	1.77	1.97	2.32	3.68
MP MB 160 3_36	500	750	1400	2500	3500	15'	10'	83	91	1.06	1.27	1.62	2.97
MP MB 160 3_40	700	950	1800	3000	4000	15'	10'	83	91	1.21	1.42	1.77	3.12
MP MB 160 3_50	700	950	1800	3000	4000	15'	10'	83	91	1.20	1.40	1.75	3.11
MP MB 160 3_70	700	950	1800	3000	4000	15'	10'	83	91	1.18	1.39	1.74	3.09
MP MB 160 3_100	350	660	1200	3000	4000	15'	10'	83	91	1.18	1.38	1.73	3.09
MP MB 160 4_48	700	950	1800	2200	3500	17'	12'	60	89	4.10	4.31	4.66	6.01
MP MB 160 4_64	700	950	1800	2200	3500	17'	12'	60	89	3.90	4.11	4.46	5.81
MP MB 160 4_75	700	950	1800	2500	3500	17'	12'	60	89	2.91	3.11	3.46	4.82
MP MB 160 4_80	700	950	1800	2200	3500	17'	12'	60	89	3.90	4.11	4.46	5.81
MP MB 160 4_84	700	950	1800	3000	4000	17'	12'	60	89	1.84	2.05	2.40	3.75
MP MB 160 4_90	350	660	1200	3000	4000	17'	12'	60	89	1.24	1.45	1.80	3.15
MP MB 160 4_120	700	950	1800	3000	4000	17'	12'	60	89	1.23	1.44	1.79	3.14
MP MB 160 4_125	700	950	1800	2500	3500	17'	12'	60	89	2.74	2.95	3.30	4.65
MP MB 160 4_140	700	950	1800	3000	4000	17'	12'	60	89	1.78	1.98	2.33	3.69
MP MB 160 4_150	700	950	1800	3000	4000	17'	12'	60	89	1.23	1.44	1.79	3.14
MP MB 160 4_160	700	950	1800	3000	4000	17'	12'	60	89	1.20	1.41	1.76	3.11
MP MB 160 4_175	700	950	1800	3000	4000	17'	12'	60	89	1.76	1.96	2.31	3.67
MP MB 160 4_200	700	950	1800	3000	4000	17'	12'	60	89	1.20	1.41	1.76	3.11
MP MB 160 4_210	700	950	1800	3000	4000	17'	12'	60	89	1.23	1.44	1.79	3.14
MP MB 160 4_250	700	950	1800	3000	4000	17'	12'	60	89	1.19	1.40	1.75	3.10
MP MB 160 4_280	700	950	1800	3000	4000	17'	12'	60	89	1.18	1.39	1.74	3.09
MP MB 160 4_350	700	950	1800	3000	4000	17'	12'	60	89	1.18	1.39	1.74	3.09
MP MB 160 4_400	700	950	1800	3000	4000	17'	12'	60	89	1.18	1.38	1.73	3.09
MP MB 160 4_500	700	950	1800	3000	4000	17'	12'	60	89	1.18	1.38	1.73	3.09
MP MB 160 4_700	700	950	1800	3000	4000	17'	12'	60	89	1.18	1.38	1.73	3.09
MP MB 160 4_1000	350	660	1200	3000	4000	17'	12'	60	89	1.18	1.38	1.73	3.09

MP

MP 190

55A1 ... 180A1

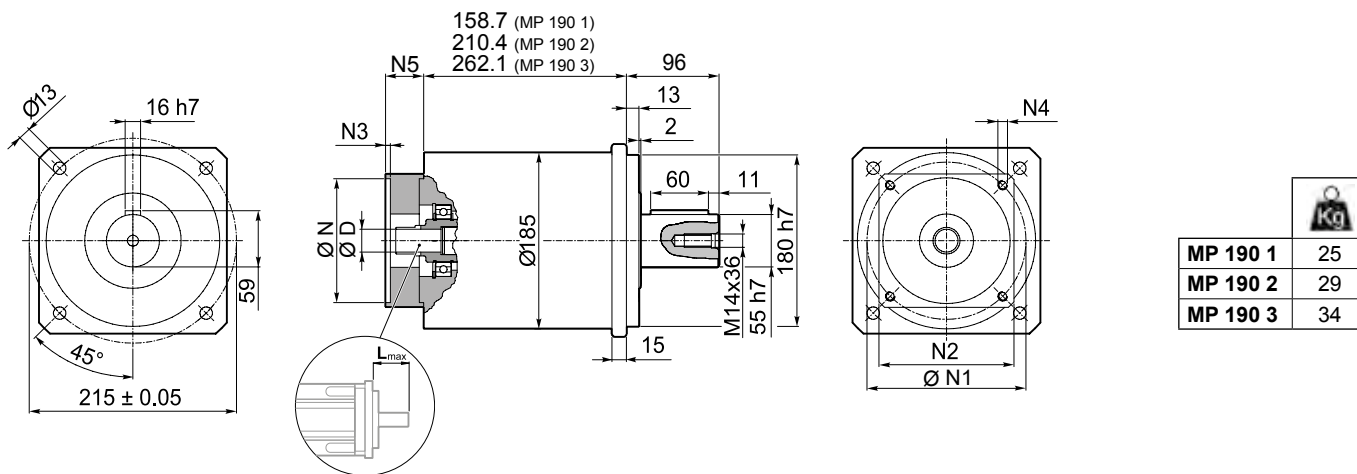

	D												N	N1	N2	N3	N4	N5	L _{max}	
55A1	14	16	19	-	-	-	-	-	-	-	-	-	-	55.5	125.7	140	5	M6x15	39.5	50
80A2	14	16	19	-	-	-	-	-	-	-	-	-	-	80	100	140	5	M6x15	39.5	50
95A1	14	16	19	22	24	-	-	-	-	-	-	-	-	95	115	140	5	M8x20	39.5	50
110A1	14	16	19	22	24	-	-	-	-	-	-	-	-	110	130	140	5	M8x20	39.5	50
110B1	14	16	19	22	24	-	-	-	-	-	-	-	-	110	145	140	6.5	M8x20	49.5	60
114A	14	16	19	22	24	28	32	35	38	42	45	48	-	114.3	200	170	6.5	M12x25	69.5	80
130A	14	16	19	22	24	-	-	-	-	-	-	-	-	130	165	140	5	M10x20	39.5	50
130A1	14	16	19	22	24	28	32	-	-	-	-	-	-	130	165	140	5	M10x20	49.5	60
180A	14	16	19	22	24	28	32	-	-	-	-	-	-	180	215	190	6.5	M14x25	49.5	60
180A1	14	16	19	22	24	28	32	35	38	42	45	48	-	180	215	190	6.5	M14x25	69.5	80

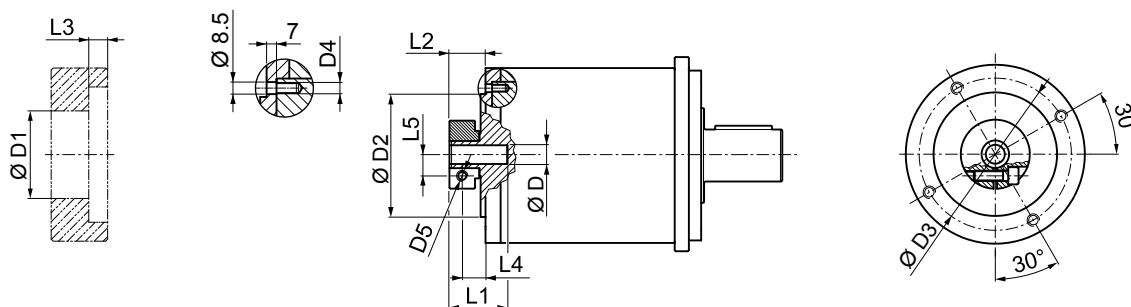

Please contact us for other motor adapters and input shaft bore.

FM

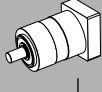

D	D1	D2	D3	D4	D5	L1	L2	L3	L4	L5	
14	16	48	130	142.5	M8x14	M6	45.5	27.5	6	20	14.5
19		51	130	142.5	M8x14	M6	45.5	27.5	6	20	16.5
22	24	56.5	130	142.5	M8x14	M6	47	29	6	20	19
28		67	130	142.5	M8x14	M8	47	29	6	20	22.5
32		71	130	142.5	M8x14	M8	47	29	6	20	24.5
35		73	130	142.5	M8x14	M8	54.5	36.5	6	25	26
38		77.5	130	142.5	M8x14	M8	54.5	36.5	6	25	28
42		92	130	142.5	M8x14	M10	60.5	40	6	25	33
45		95	130	142.5	M8x14	M10	60.5	40	6	25	33
48		97	130	142.5	M8x14	M10	60.5	40	6	25	33

MP 190

	i	M _{n 2} [Nm]	M _{a 2} [Nm]	M _{p 2} [Nm]	n ₁ [min ⁻¹]	n _{1 max} [min ⁻¹]	φ _S [arcmin]	φ _R [arcmin]	C _t [$\frac{Nm}{arcmin}$]	R _{2 max} [N]	A _{2 max} [N]	η %	J _G [kgcm ²]				
														14 ... 24	28 - 32	35 - 35	42
MP 190 1_3		500	800	1400	1500	2500	15'	10'	130	14000	15000	97	24.20	24.88	25.65	29.30	29.90
MP 190 1_4		700	950	1800	2100	3000	15'	10'	130	14000	15000	97	13.41	14.09	14.85	18.51	19.11
MP 190 1_5		700	950	1800	2300	3000	15'	10'	130	14000	15000	97	9.32	10.00	10.77	14.42	15.02
MP 190 1_6		700	950	1800	2300	3000	15'	10'	130	14000	15000	97	2.88	3.56	4.33	7.98	8.58
MP 190 1_7		700	950	1800	2900	3500	15'	10'	130	14000	15000	97	5.68	6.36	7.13	10.78	11.38
MP 190 1_10		500	800	1400	2900	3500	15'	10'	130	14000	15000	97	3.57	4.25	5.02	8.67	9.27
MP 190 2_9		500	800	1400	1500	2500	15'	10'	100	14000	15000	94	23.23	23.91	24.67	28.33	28.93
MP 190 2_12		1000	1200	2200	1500	2500	15'	10'	100	14000	15000	94	22.03	22.71	23.48	27.13	27.73
MP 190 2_15		1000	1200	2200	1500	2500	15'	10'	100	14000	15000	94	21.58	22.25	23.02	26.68	27.27
MP 190 2_16		1000	1200	2200	2100	3000	15'	10'	100	14000	15000	94	12.19	12.86	13.63	17.29	17.89
MP 190 2_20		1000	1200	2200	2300	3000	15'	10'	100	14000	15000	94	8.54	9.22	9.98	13.64	14.24
MP 190 2_25		1000	1200	2200	2300	3000	15'	10'	100	14000	15000	94	8.37	9.05	9.82	13.48	14.07
MP 190 2_28		1000	1200	2200	2900	3500	15'	10'	100	14000	15000	94	5.28	5.96	6.73	10.38	10.98
MP 190 2_30		500	800	1400	2900	3500	15'	10'	100	14000	15000	94	3.48	4.16	4.93	8.58	9.18
MP 190 2_35		1000	1200	2200	2900	3500	15'	10'	100	14000	15000	94	5.20	5.87	6.64	10.30	10.90
MP 190 2_36		700	950	1800	2300	3000	15'	10'	100	14000	15000	94	2.18	2.86	3.63	7.28	7.88
MP 190 2_40		1000	1200	2200	2900	3500	15'	10'	100	14000	15000	94	3.37	4.05	4.82	8.48	9.07
MP 190 2_50		1000	1200	2200	2900	3500	15'	10'	100	14000	15000	94	3.33	4.01	4.78	8.44	9.03
MP 190 2_70		1000	1200	2200	2900	3500	15'	10'	100	14000	15000	94	3.30	3.97	4.74	8.40	9.00
MP 190 2_100		500	800	1400	2900	3500	15'	10'	100	14000	15000	94	3.28	3.95	4.72	8.38	8.98
MP 190 3_48		1000	1200	2200	2100	3000	17'	12'	90	14000	15000	91	12.73	13.40	14.17	17.83	18.43
MP 190 3_64		1000	1200	2200	2100	3000	17'	12'	90	14000	15000	91	12.10	12.78	13.55	17.21	17.80
MP 190 3_75		1000	1200	2200	2300	3000	17'	12'	90	14000	15000	91	8.86	9.54	10.31	13.97	14.56
MP 190 3_80		1000	1200	2200	2100	3000	17'	12'	90	14000	15000	91	12.09	12.76	13.53	17.19	17.79
MP 190 3_84		1000	1200	2200	2900	3500	17'	12'	90	14000	15000	91	5.46	6.13	6.90	10.56	11.16
MP 190 3_90		500	800	1400	2900	3500	17'	12'	90	14000	15000	91	3.47	4.15	4.92	8.57	9.17
MP 190 3_120		1000	1200	2200	2900	3500	17'	12'	90	14000	15000	91	3.46	4.14	4.91	8.56	9.16
MP 190 3_125		1000	1200	2200	2300	3000	17'	12'	90	14000	15000	91	8.34	9.01	9.78	13.44	14.04
MP 190 3_140		1000	1200	2200	2900	3500	17'	12'	90	14000	15000	91	5.25	5.92	6.69	10.35	10.95
MP 190 3_150		1000	1200	2200	2900	3500	17'	12'	90	14000	15000	91	3.46	4.13	4.90	8.56	9.15
MP 190 3_160		1000	1200	2200	2900	3500	17'	12'	90	14000	15000	91	3.36	4.04	4.81	8.46	9.06
MP 190 3_175		1000	1200	2200	2900	3500	17'	12'	90	14000	15000	91	5.18	5.85	6.62	10.28	10.88
MP 190 3_200		1000	1200	2200	2900	3500	17'	12'	90	14000	15000	91	3.36	4.03	4.80	8.46	9.06
MP 190 3_210		1000	1200	2200	2900	3500	17'	12'	90	14000	15000	91	3.45	4.13	4.90	8.55	9.15
MP 190 3_250		1000	1200	2200	2900	3500	17'	12'	90	14000	15000	91	3.32	4.00	4.77	8.42	9.02
MP 190 3_280		1000	1200	2200	2900	3500	17'	12'	90	14000	15000	91	3.29	3.97	4.74	8.39	8.99
MP 190 3_350		1000	1200	2200	2900	3500	17'	12'	90	14000	15000	91	3.29	3.97	4.74	8.39	8.99
MP 190 3_400		1000	1200	2200	2900	3500	17'	12'	90	14000	15000	91	3.27	3.95	4.72	8.38	8.97
MP 190 3_500		1000	1200	2200	2900	3500	17'	12'	90	14000	15000	91	3.27	3.95	4.72	8.38	8.97
MP 190 3_700		1000	1200	2200	2900	3500	17'	12'	90	14000	15000	91	3.27	3.95	4.72	8.38	8.97
MP 190 3_1000		500	800	1400	2900	3500	17'	12'	90	14000	15000	91	3.27	3.95	4.72	8.38	8.97

MP

6.3.1 MACHINE SHAFT

Pivot of driven equipment should be made from high grade alloy steel. Table below shows recommended dimensions for the Customer to consider when designing mating shaft. A device retaining the shaft axially is also recommended (not shown). The number and size of relative tapped holes at shaft end depend on application requirements.

MB

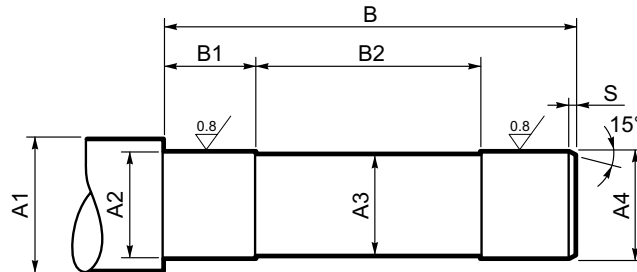

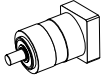
	A1	A2	A3	A4	B	B1	B2	S
MP MB 080	≥ 25	20 h7	18	20 h7	178	50	90	1
MP MB 105	≥ 40	32 h7	30	32 h7	205	60	115	
MP MB 130/160	≥ 50	42 h7	40	42 h7	259	70	140	

MP

LC PLANETARY PRECISION GEARBOX IN LINE

LC planetary precision gearboxes represent a flexible solution, and economic alternative together with an optimal performance and reliability.

Improved Performance as the key to downsizing

Enhanced performance of our LC precision gearbox (New "P" option) may open up important downsizing in many applications where previously was impossible to ensure a higher transmissible output torque.

As an additional benefit, downsizing lead to an improvement of energy efficiency by selecting a more compact gearbox with higher torque density and reducing significantly the acceleration mass.

Transmissible torque is now improved up to 40%.

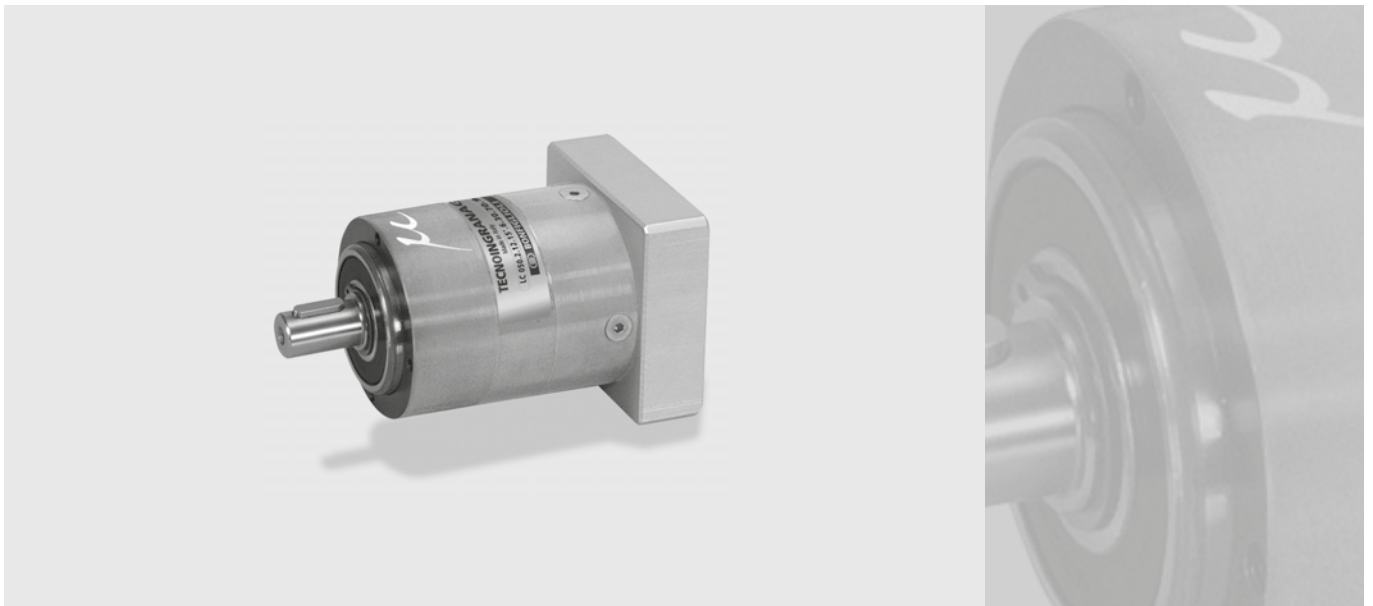

Product Line Up:

- High Torque Density Option "P" available to extend Product Performance
- Optimal Acceleration and Nominal Torques
- Optimal Radial and Axial Load Capacities
- Designed for Cyclic and Continuous Duty
- Optimal Torsional Stiffness
- Geometrical Backlash less than 6 arcmin
- Universal Design allow any Mounting Orientation

7 FEATURES OF LC SERIES

Planetary gear units of the LC series belong to a range of low backlash drives very broad and complete as far as transmissible torque, gear ratios and circumferential backlash.

All units are generously proportioned to run quietly and provide a long service life without maintenance requirements.

Motor mounting is an operation that can be easily conducted without the need of any particular tooling, other than that usually available in a normally equipped workshop.

- Available with either standard (STD) or reduced (LOW) backlash:
1-stage units: standard $\varphi_S \leq 12'$; reduced $\varphi_R \leq 6'$
2-stage units: standard $\varphi_S \leq 15'$; reduced $\varphi_R \leq 8'$
- A high IP rating (IP64) provides inner parts with protection against the ingress of dust and liquids.
- Input section oil seals made from a Fluoroelastomer compound are supplied as standard.
- Noise pressure level $L_P \leq 70$ dB(A). Conditions: distance 1 m; measured without load an input speed of $n_1 = 3000 \text{ min}^{-1}$; $i=10$.
- Wide range of adapter flanges matching the most popular brands of motors
- Units are factory filled with synthetic grease to NLGI consistency class 00, in the absence of contamination the lubricant requires no periodical changes.
- Ambient temperature min -20°C , max $+30^\circ\text{C}$. For temperature higher than 30°C please consider derating factor f_T .
- Housing temperature must not exceed $T_{\text{max}} = 90^\circ\text{C}$.
- Available as Version P with higher output Torque.

		Distribution of nominal torque M_{n2} [Nm]																				
	[i]	3	4	5	7	9	10	12	15	16	20	25	28	30	35	36	40	45	50	70	81	100
LC 050	10	12	12	12	12	10	-	12	12	12	12	12	12	-	12	12	-	12	-	-	10	-
LC 070	18	25	25	25	18	18	18	25	25	25	25	25	25	18	25	-	25	-	25	25	-	18
LC 070P	29	30	25	25	29	18	29	29	29	30	30	30	30	29	30	-	30	-	30	30	-	18
LC 090	37	43	43	43	37	37	37	43	43	43	43	43	43	37	43	-	43	-	43	43	-	37
LC 090P	65	60	50	50	65	40	65	65	60	60	50	50	65	50	-	60	-	50	50	-	40	
LC 120	95	110	110	110	95	95	110	110	110	110	110	110	110	95	110	-	110	-	110	110	-	95
LC 120P	155	155	125	125	155	100	155	155	155	155	125	125	125	155	125	-	155	-	125	125	-	100
LC 155	250	300	300	300	250	230	300	300	300	300	300	300	300	250	300	-	300	-	300	300	-	230
LC 155P	250	350	350	350	250	230	450	450	450	450	450	450	450	250	450	-	450	-	450	450	-	230

LC

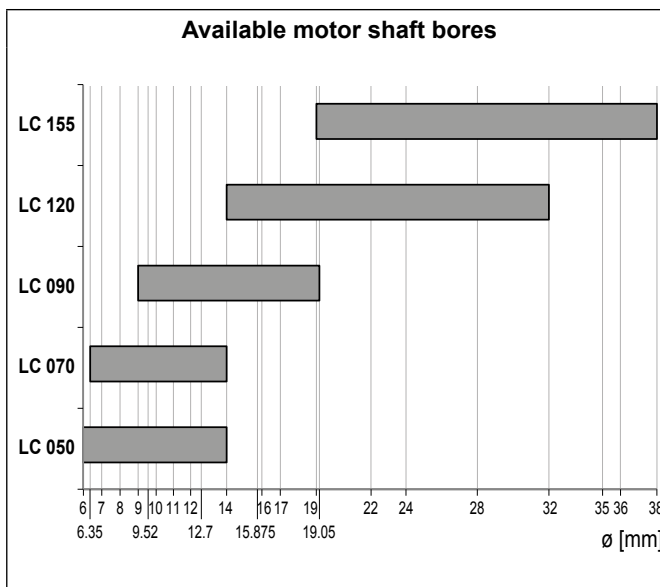
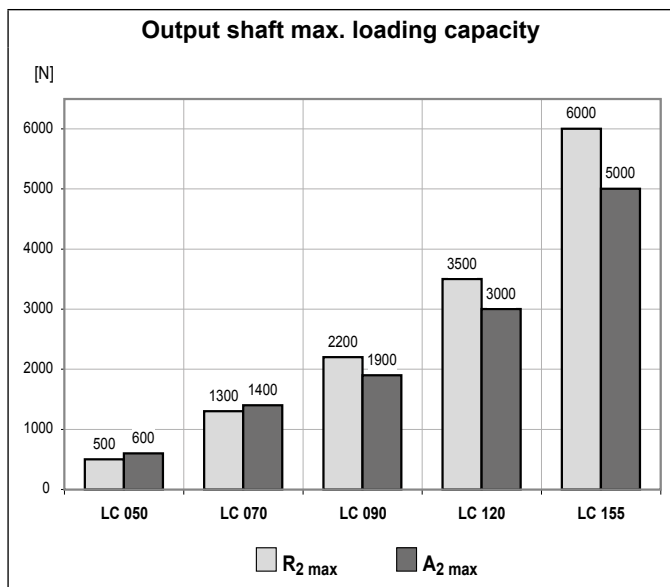

7.1 ORDERING CODE

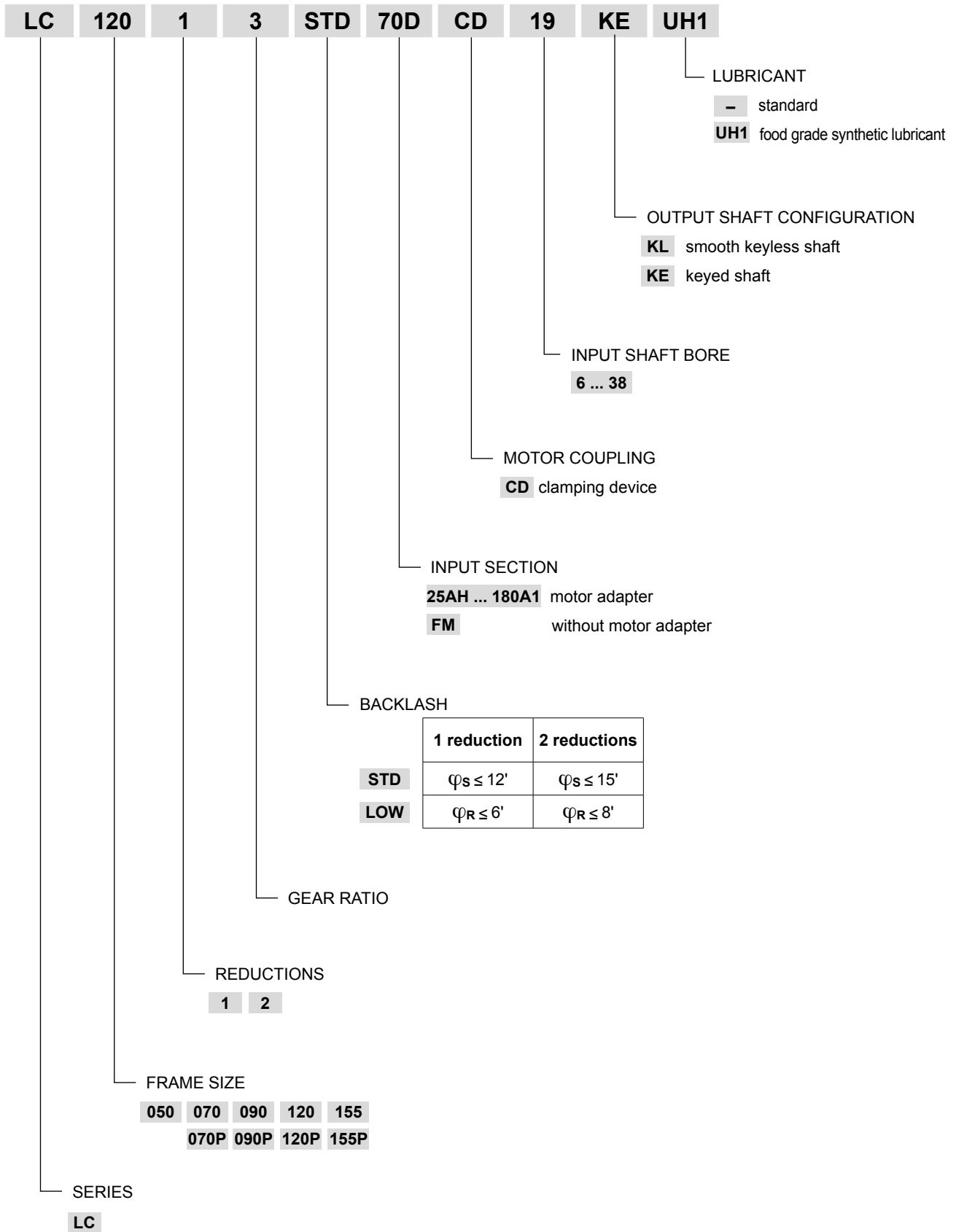

S-M-BOR-NL-CAFS-001-V01

LC

7.2 DIMENSIONS AND TECHNICAL SPECIFICATIONS

LC 050

25AH ... 80A

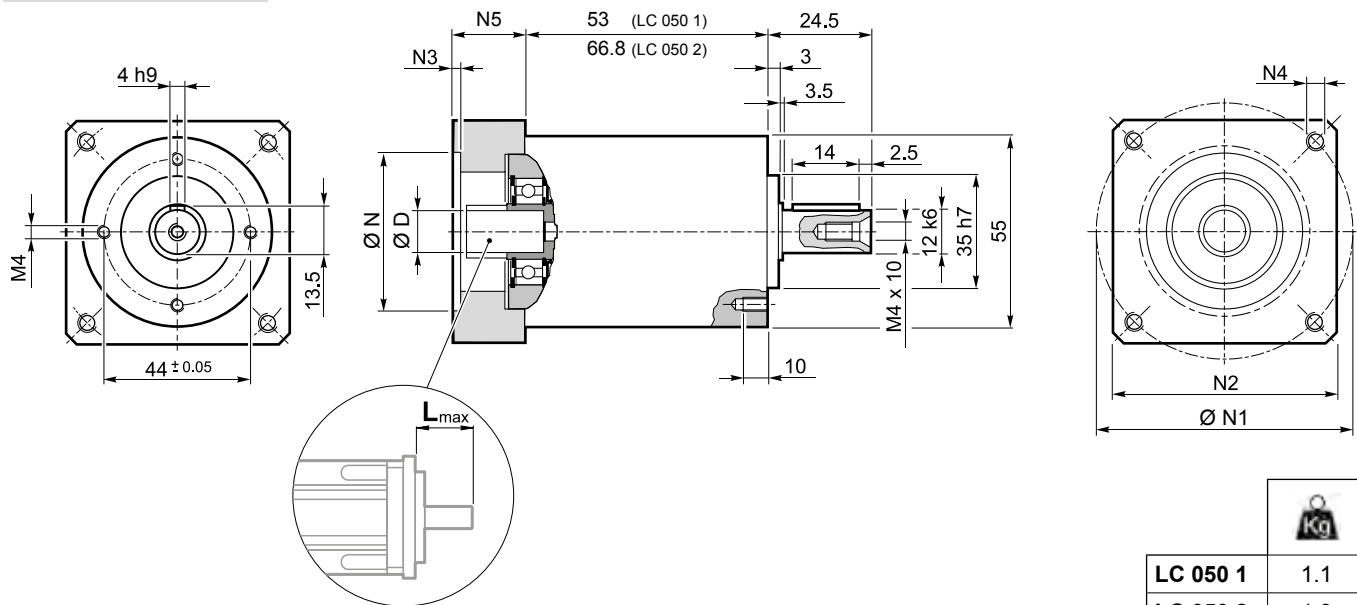

LC

Image	D	N	N1		N2	N3	N4	N5	L _{max}
			min	max					
25AH	6 6.35 7 8 9 9.52 - - - - -	25	36	48	55	3.5	4.5	25	25
26AH	6 6.35 7 8 9 9.52 - - - - -	26	36	48					
28AH	6 6.35 7 8 9 9.52 - - - - -	28	36	48					
30AH	6 6.35 7 8 9 9.52 - - - - -	30	36	48					
32AH	6 6.35 7 8 9 9.52 - - - - -	32	38	48					
34AH	6 6.35 7 8 9 9.52 - - - - -	34	40	48					
36AH	6 6.35 7 8 9 9.52 - - - - -	36	42	48					
38AH	6 6.35 7 8 9 9.52 - - - - -	38	44	48					
40AH	6 6.35 7 8 9 9.52 - - - - -	40	46	48					
38B	6 6.35 7 8 9 9.52 10 11 12 12.7 -	38.1	66.6	60	3	M4x10	18	25	
40B	6 6.35 7 8 9 9.52 10 11 12 12.7 -	40	63	60	3	M4x10	18	25	
50A	6 6.35 7 8 9 9.52 10 11 12 12.7 -	50	60	60	3	M4x10	18	25	
50B	6 6.35 7 8 9 9.52 10 11 12 12.7 14	50	65	60	3	M5x12	23	30	
50BH	6 6.35 7 8 9 9.52 10 11 12 12.7 14	50	65	60	4	5.5	23	30	
50C	6 6.35 7 8 9 9.52 10 11 12 12.7 14	50	70	60	3	M4x10	23	30	
50MH	6 6.35 7 8 9 9.52 10 11 12 12.7 -	50	65	55	4	5.5	16	23	
60A	6 6.35 7 8 9 9.52 10 11 12 12.7 -	60	75	63	3	M5x12	18	25	
60AH	6 6.35 7 8 9 9.52 10 11 12 12.7 -	60	75	65	3	5.5	18	25	
60A1	6 6.35 7 8 9 9.52 10 11 12 12.7 14	60	75	63	3	M5x12	23	30	
60AH1	6 6.35 7 8 9 9.52 10 11 12 12.7 14	60	75	65	3	5.5	23	30	
60B	6 6.35 7 8 9 9.52 10 11 12 12.7 14	60	85	75	3	M5x12	23	30	
60C	6 6.35 7 8 9 9.52 10 11 12 12.7 14	60	90	75	3	M5x12	23	30	
70A	6 6.35 7 8 9 9.52 10 11 12 12.7 14	70	85	75	3	M6x15	23	30	
70B	6 6.35 7 8 9 9.52 10 11 12 12.7 14	70	90	75	3	M5x12	23	30	
73A	6 6.35 7 8 9 9.52 10 11 12 12.7 14	73	98.4	85	3	M5x12	25	32	
80A	6 6.35 7 8 9 9.52 10 11 12 12.7 14	80	100	85	3	M6x15	23	30	

Please contact us for other motor adapters and input shaft bore.

LC 050

FM

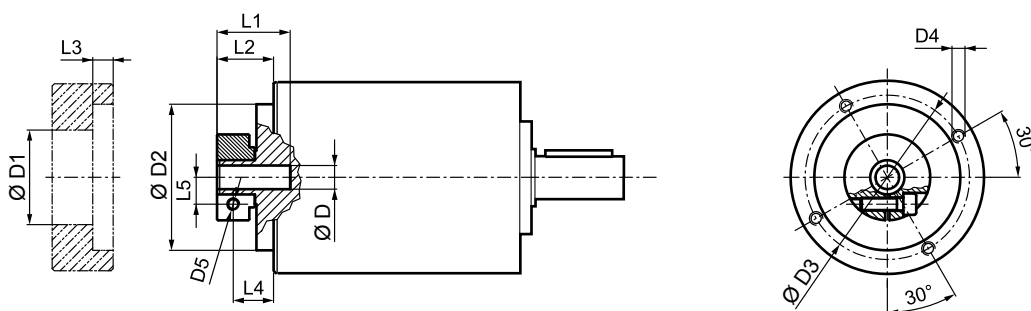

			D1	D2	D3	D4	D5	L1	L2	L3	L4	L5
6	6.35	7	32.5	50	42.5	M4x8	M4	21.7	13.2	3	8.2	8
8	9	9.52	32.5	50	42.5	M4x8	M4	21.7	13.2	3	8.2	9
11	12	12.7	35.5	50	42.5	M4x8	M4	22	13.5	3	8.5	11
14			35.5	50	42.5	M4x8	M4	25	17	3	10.2	11.5

	i	M _{n 2}	M _{a 2}	M _{p 2}	n ₁	n _{1 max}	φ _S	φ _R	C _t	R _{2 max}	A _{2 max}	η	J _G [kgcm ²]	
		[Nm]	[Nm]	[Nm]	[min ⁻¹]	[min ⁻¹]	[arcmin]	[arcmin]	[Nm / arcmin]	[N]	[N]	%	6 ... 9.52	10 ... 14
LC 050 1_3	10	16	28	3300	4000	12'	6'	0.9	500	600	97	0.07	0.10	
LC 050 1_4	12	20	30	3500	5000	12'	6'	0.9	500	600	97	0.06	0.08	
LC 050 1_5	12	20	30	3500	5000	12'	6'	0.9	500	600	97	0.05	0.07	
LC 050 1_7	12	20	30	4000	5000	12'	6'	0.9	500	600	97	0.04	0.06	
LC 050 1_9	10	16	28	4000	6000	12'	6'	0.9	500	600	97	0.04	0.06	
LC 050 2_12	12	20	30	3300	4000	15'	8'	0.75	500	600	94	0.07	0.09	
LC 050 2_15	12	20	30	3300	4000	15'	8'	0.75	500	600	94	0.07	0.09	
LC 050 2_16	12	20	30	3500	5000	15'	8'	0.75	500	600	94	0.05	0.07	
LC 050 2_20	12	20	30	3500	5000	15'	8'	0.75	500	600	94	0.05	0.07	
LC 050 2_25	12	20	30	3500	5000	15'	8'	0.75	500	600	94	0.05	0.07	
LC 050 2_28	12	20	30	4000	5000	15'	8'	0.75	500	600	94	0.04	0.06	
LC 050 2_35	12	20	30	4000	5000	15'	8'	0.75	500	600	94	0.04	0.06	
LC 050 2_36	12	20	30	4000	6000	15'	8'	0.75	500	600	94	0.04	0.06	
LC 050 2_45	12	20	30	4000	6000	15'	8'	0.75	500	600	94	0.04	0.06	
LC 050 2_81	10	16	28	4000	6000	15'	8'	0.75	500	600	94	0.04	0.06	

LC 070

25AH ... 80A

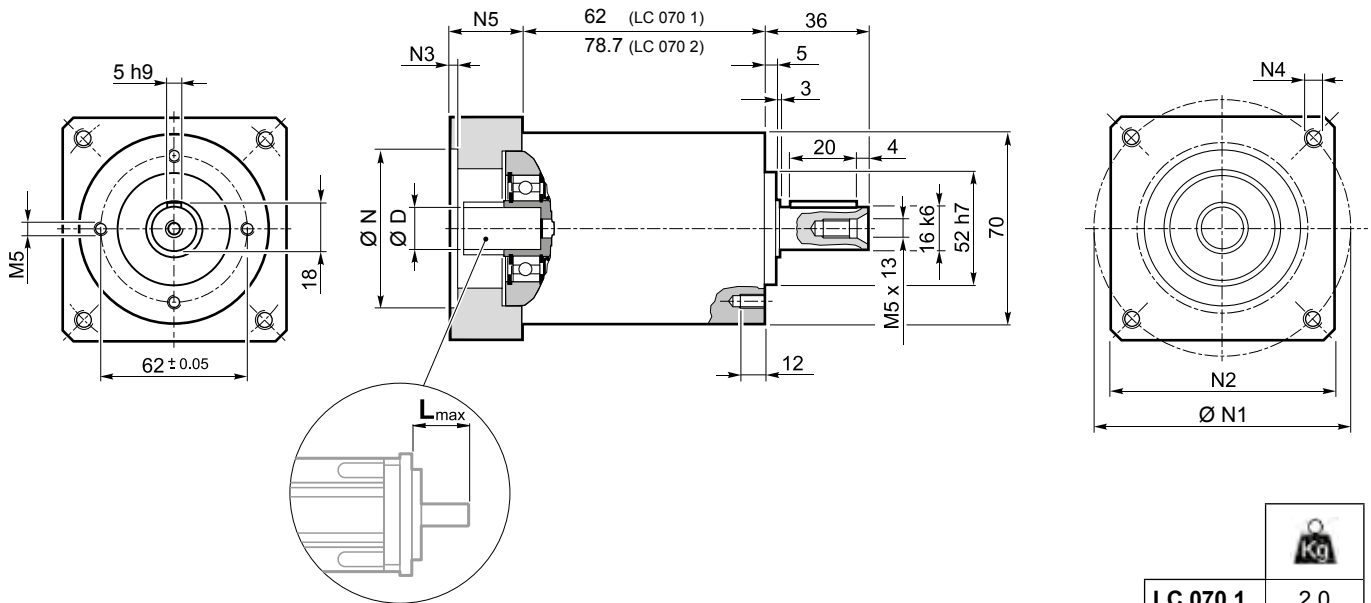

LC 070 1	2.0
LC 070 2	2.3

											N	N1		N2	N3	N4	N5	L _{max}
												min	max					
25AH	6.35	7	8	9	9.52	-	-	-	-	-	25	39	56	65	3.5	4.5	25	25
26AH	6.35	7	8	9	9.52	-	-	-	-	-	26	39	56					
28AH	6.35	7	8	9	9.52	-	-	-	-	-	28	39	56					
30AH	6.35	7	8	9	9.52	-	-	-	-	-	30	39	56					
32AH	6.35	7	8	9	9.52	-	-	-	-	-	32	39	56					
34AH	6.35	7	8	9	9.52	-	-	-	-	-	34	40	56					
36AH	6.35	7	8	9	9.52	-	-	-	-	-	36	42	56					
39AH	6.35	7	8	9	9.52	-	-	-	-	-	39	45	56					
40AH	6.35	7	8	9	9.52	-	-	-	-	-	40	46	56					
38B	6.35	7	8	9	9.52	10	11	12	12.7	-	38.1	66.6	60	3	M4x10	18	25	
40B	6.35	7	8	9	9.52	10	11	12	12.7	-	40	63	60	3	M4x10	18	25	
50A	6.35	7	8	9	9.52	10	11	12	12.7	-	50	60	60	3	M4x10	18	25	
50B	6.35	7	8	9	9.52	10	11	12	12.7	14	50	65	60	3	M5x12	23	30	
50BH	6.35	7	8	9	9.52	10	11	12	12.7	14	50	65	65	3	5.5	25	32	
50C	6.35	7	8	9	9.52	10	11	12	12.7	14	50	70	60	3	M4x10	23	30	
55MH	6.35	7	8	9	9.52	10	11	12	12.7	-	55	80	65	2	5.5	16	23	
60A	6.35	7	8	9	9.52	10	11	12	12.7	-	60	75	63	3	M5x12	18	25	
60A1	6.35	7	8	9	9.52	10	11	12	12.7	14	60	75	63	3	M5x12	23	30	
60B	6.35	7	8	9	9.52	10	11	12	12.7	14	60	85	75	3	M5x12	23	30	
60C	6.35	7	8	9	9.52	10	11	12	12.7	14	60	90	75	3	M5x12	23	30	
70A	6.35	7	8	9	9.52	10	11	12	12.7	14	70	85	75	3	M6x15	23	30	
70B	6.35	7	8	9	9.52	10	11	12	12.7	14	70	90	75	3	M5x12	23	30	
73A	6.35	7	8	9	9.52	10	11	12	12.7	14	73	98.4	85	3	M5x12	25	32	
80A	6.35	7	8	9	9.52	10	11	12	12.7	14	80	100	85	3	M6x15	23	30	

Please contact us for other motor adapters and input shaft bore.

LC 070

FM

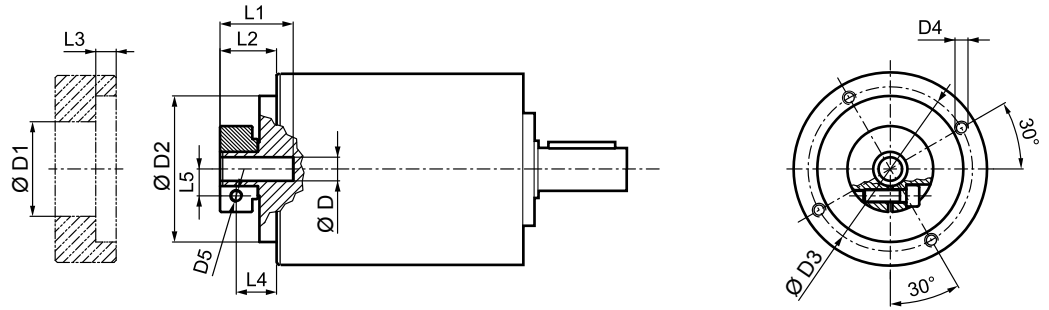

				D1	D2	D3	D4	D5	L1	L2	L3	L4	L5
6.35	7			32.5	50	42.5	M4x8	M4	21.7	13.2	3	8.2	8
8	9	9.52	10	32.5	50	42.5	M4x8	M4	21.7	13.2	3	8.2	9
11	12	12.7		35.5	50	42.5	M4x8	M4	22	13.5	3	8.5	11
14				35.5	50	42.5	M4x8	M4	25	17	3	10.2	11.5

	i	M _{n 2}	M _{a 2}	M _{p 2}	n ₁	n _{1 max}	φ _S	φ _R	C _t	R _{2 max}	A _{2 max}	η	J _G [kgcm ²]	
		[Nm]	[Nm]	[Nm]	[min ⁻¹]	[min ⁻¹]	[arcmin]	[arcmin]	$\frac{Nm}{arcmin}$	[N]	[N]	%		6.35 ... 9.52
LC 070 1_3		18	30	60	3300	4000	12'	6'	3	1300	1400	97	0.12	0.14
LC 070 1_4		25	35	70	3500	5000	12'	6'	3	1300	1400	97	0.08	0.10
LC 070 1_5		25	35	70	3500	5000	12'	6'	3	1300	1400	97	0.06	0.09
LC 070 1_7		25	35	70	4000	5000	12'	6'	3	1300	1400	97	0.05	0.07
LC 070 1_10		18	30	60	4000	6000	12'	6'	3	1300	1400	97	0.04	0.06
LC 070 2_9		18	30	60	3300	4000	15'	8'	2.5	1300	1400	94	0.11	0.13
LC 070 2_12		25	35	70	3300	4000	15'	8'	2.5	1300	1400	94	0.10	0.13
LC 070 2_15		25	35	70	3300	4000	15'	8'	2.5	1300	1400	94	0.10	0.12
LC 070 2_16		25	35	70	3500	5000	15'	8'	2.5	1300	1400	94	0.07	0.09
LC 070 2_20		25	35	70	3500	5000	15'	8'	2.5	1300	1400	94	0.06	0.08
LC 070 2_25		25	35	70	3500	5000	15'	8'	2.5	1300	1400	94	0.06	0.08
LC 070 2_28		25	35	70	4000	5000	15'	8'	2.5	1300	1400	94	0.05	0.07
LC 070 2_30		18	30	60	4000	6000	15'	8'	2.5	1300	1400	94	0.04	0.06
LC 070 2_35		25	35	70	4000	5000	15'	8'	2.5	1300	1400	94	0.05	0.07
LC 070 2_40		25	35	70	4000	6000	15'	8'	2.5	1300	1400	94	0.04	0.06
LC 070 2_50		25	35	70	4000	6000	15'	8'	2.5	1300	1400	94	0.04	0.06
LC 070 2_70		25	35	70	4000	6000	15'	8'	2.5	1300	1400	94	0.04	0.06
LC 070 2_100		18	30	60	4000	6000	15'	8'	2.5	1300	1400	94	0.04	0.06

LC 090

40B1 ... 110B1

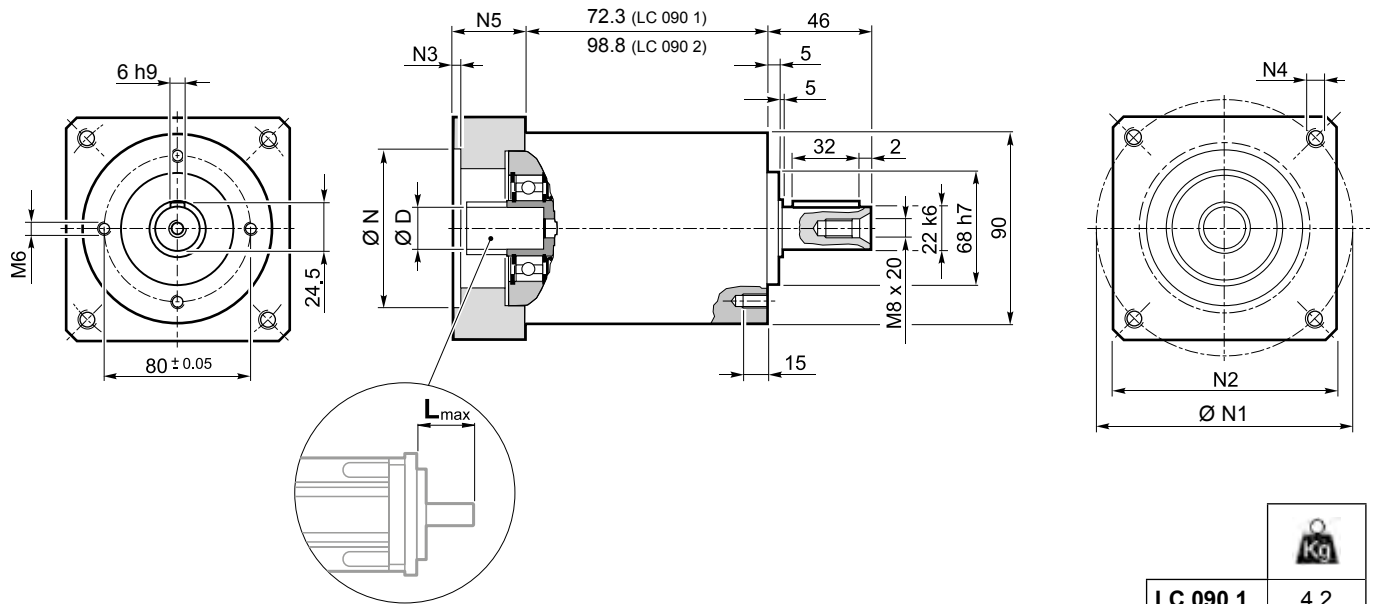

												N	N1	N2	N3	N4	N5	L _{max}
	9	9.52	11	12	12.7	14	-	-	-	-	-							
40B1	9	9.52	11	12	12.7	14	-	-	-	-	-	40	63	80	4	M4x10	34	40
45A	9	9.52	11	12	12.7	-	-	-	-	-	-	45	63	80	4	M4x10	34	40
50B1	9	9.52	11	12	12.7	14	-	-	-	-	-	50	65	80	4	M5x16	34	40
50BH1	9	9.52	11	12	12.7	14	-	-	-	-	-	50	65	80	4	5.5	34	40
50C1	9	9.52	11	12	12.7	14	-	-	-	-	-	50	70	80	4	M4x10	34	40
50D	9	9.52	11	12	12.7	14	-	-	-	-	-	50	95	80	4	M6x10	34	40
55A	9	9.52	11	12	12.7	14	15.875	16	17	19	19.05	55.5	125.7	105	4	M6x16	34	40
60A2	9	9.52	11	12	12.7	14	-	-	-	-	-	60	75	80	4	M5x16	34	40
60AH2	9	9.52	11	12	12.7	14	-	-	-	-	-	60	75	90	4	5.5	34	40
60B1	9	9.52	11	12	12.7	14	15.875	16	-	-	-	60	85	80	4	M5x16	34	40
60C1	9	9.52	11	12	12.7	14	15.875	16	-	-	-	60	90	80	4	M5x16	34	40
70A1	9	9.52	11	12	12.7	14	15.875	16	17	19	19.05	70	85	80	4	M6x20	34	40
70AH1	9	9.52	11	12	12.7	14	15.875	16	17	19	19.05	70	85	90	4	6.5	34	40
70B1	9	9.52	11	12	12.7	14	15.875	16	17	19	19.05	70	90	80	4	M5x16	34	40
73A1	9	9.52	11	12	12.7	14	-	-	-	-	-	73	98.4	85	4	M5x16	34	40
80A1	9	9.52	11	12	12.7	14	15.875	16	17	19	19.05	80	100	90	4	M6x16	34	40
95A	9	9.52	11	12	12.7	14	15.875	16	17	19	19.05	95	115	100	4	M8x20	34	40
95B	9	9.52	11	12	12.7	14	15.875	16	17	19	19.05	95	130	115	4	M8x20	34	40
110A	9	9.52	11	12	12.7	14	15.875	16	17	19	19.05	110	130	115	4	M8x20	34	40
110B	9	9.52	11	12	12.7	14	15.875	16	17	19	19.05	110	145	120	6.5	M8x20	44	50
110B1	9	9.52	11	12	12.7	14	15.875	16	17	19	19.05	110	145	120	6.5	M8x20	54	60

Please contact us for other motor adapters and input shaft bore.

LC 090

FM

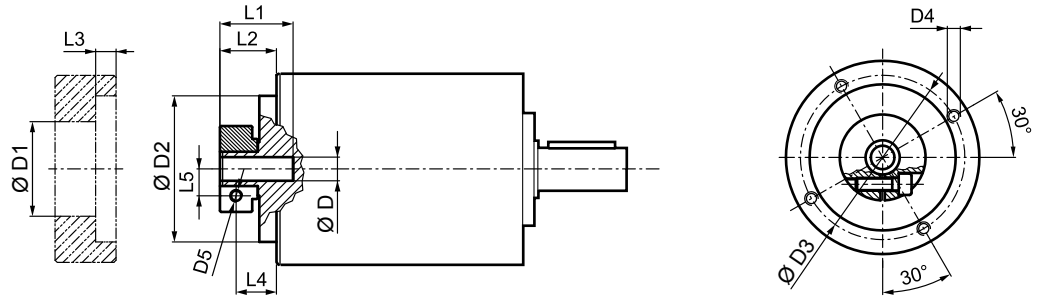



		D1	D2	D3	D4	D5	L1	L2	L3	L4	L5
9	9.52	38	68	76.5	M6x10	M6	34	26.8	9.5	18.8	10.5
11	12 12.7	43	68	76.5	M6x10	M6	34	26.8	9.5	18.8	12.5
14	15.875 16 17	48	68	76.5	M6x10	M6	34	26.8	9.5	18.8	14.5
19	19.05	51	68	76.5	M6x10	M6	34	26.8	9.5	18.8	16.5

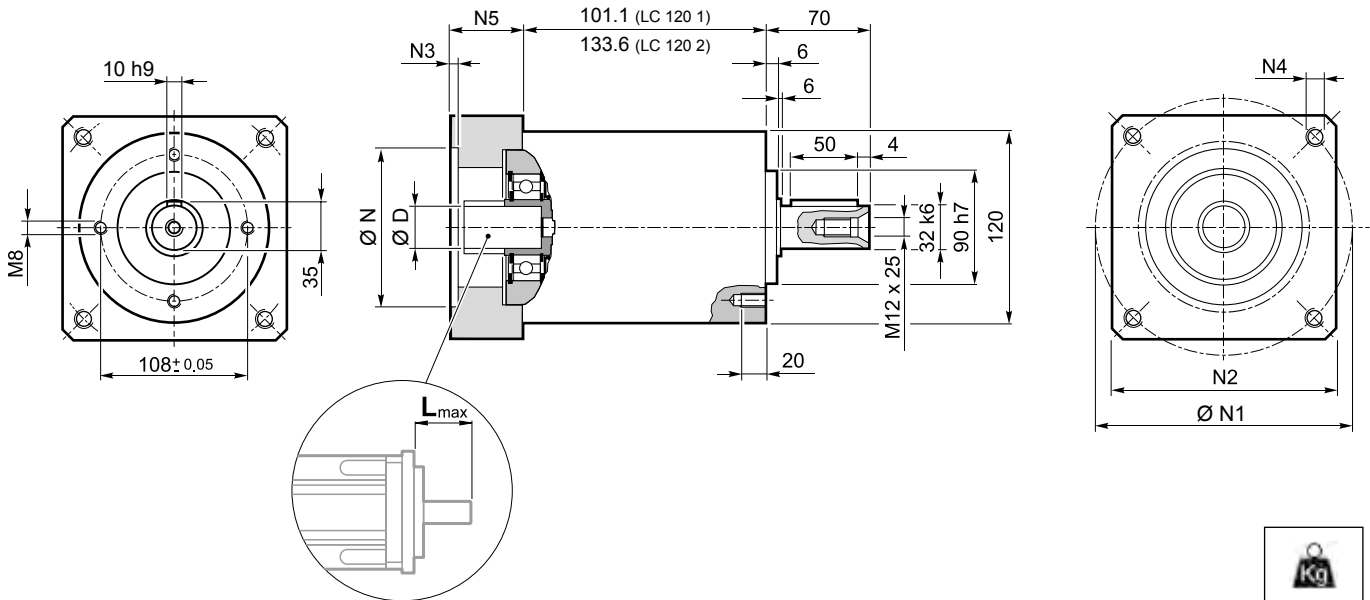

	i	M _{n2} [Nm]	M _{a2} [Nm]	M _{p2} [Nm]	n ₁ [min ⁻¹]	n _{1 max} [min ⁻¹]	φ _S [arcmin]	φ _R [arcmin]	C _t [Nm/arcmin]	R _{2 max} [N]	A _{2 max} [N]	η %	J _G [kgcm ²]	
														9 ... 12.7
LC 090 1_3		37	70	150	2900	3500	12'	6'	9	2200	1900	97	0.62	0.77
LC 090 1_4		43	80	160	3100	4500	12'	6'	9	2200	1900	97	0.41	0.55
LC 090 1_5		43	80	160	3200	4500	12'	6'	9	2200	1900	97	0.33	0.47
LC 090 1_7		43	80	160	4000	4500	12'	6'	9	2200	1900	97	0.26	0.40
LC 090 1_10		37	70	150	4000	6000	12'	6'	9	2200	1900	97	0.21	0.35
LC 090 2_9		37	70	150	2900	3500	15'	8'	8.5	2200	1900	94	0.47	0.61
LC 090 2_12		43	80	160	2900	3500	15'	8'	8.5	2200	1900	94	0.44	0.58
LC 090 2_15		43	80	160	2900	3500	15'	8'	8.5	2200	1900	94	0.43	0.57
LC 090 2_16		43	80	160	3100	4500	15'	8'	8.5	2200	1900	94	0.31	0.45
LC 090 2_20		43	80	160	3200	4500	15'	8'	8.5	2200	1900	94	0.26	0.40
LC 090 2_25		43	80	160	3200	4500	15'	8'	8.5	2200	1900	94	0.26	0.40
LC 090 2_28		43	80	160	4000	4500	15'	8'	8.5	2200	1900	94	0.22	0.36
LC 090 2_30		37	70	150	4000	6000	15'	8'	8.5	2200	1900	94	0.20	0.34
LC 090 2_35		43	80	160	4000	4500	15'	8'	8.5	2200	1900	94	0.22	0.36
LC 090 2_40		43	80	160	4000	6000	15'	8'	8.5	2200	1900	94	0.20	0.34
LC 090 2_50		43	80	160	4000	6000	15'	8'	8.5	2200	1900	94	0.20	0.34
LC 090 2_70		43	80	160	4000	6000	15'	8'	8.5	2200	1900	94	0.20	0.34
LC 090 2_100		37	70	150	4000	6000	15'	8'	8.5	2200	1900	94	0.19	0.34

LC 120

50D ... 130A1



	
LC 120 1	9.6
LC 120 2	12.1

										N	N1	N2	N3	N4	N5	L _{max}
	D															
50D	14	15	15.875	16	19	-	-	-	-	50	95	100	5	M6x14	28	40
55A	14	15	15.875	16	19	-	-	-	-	55.5	125.7	105	5	M6x16	28	40
60A2	14	15	15.875	16	19	-	-	-	-	60	75	100	5	M5x14	28	40
60AH2	14	15	15.875	16	19	-	-	-	-	60	75	100	5	6.5	33	40
60B1	14	15	15.875	16	19	-	-	-	-	60	85	100	6.5	M5x14	28	40
70A1	14	15	15.875	16	19	-	-	-	-	70	85	100	5	M6x14	28	40
70AH1	14	15	15.875	16	19	-	-	-	-	70	85	100	5	6	33	40
70B1	14	15	15.875	16	19	-	-	-	-	70	90	100	5	M5x12	28	40
80A1	14	15	15.875	16	19	-	-	-	-	80	100	100	5	M6x16	28	40
80AH1	14	15	15.875	16	19	-	-	-	-	80	100	100	5	6.5	28	40
95A	14	15	15.875	16	19	-	-	-	-	95	115	100	5	M8x18	28	40
95A1	14	15	15.875	16	19	22	24	-	-	95	115	100	5	M8x18	38	50
95B	14	15	15.875	16	19	-	-	-	-	95	130	115	5	M8x18	28	40
110A	14	15	15.875	16	19	-	-	-	-	110	130	115	5	M8x18	28	40
110A1	14	15	15.875	16	19	22	24	-	-	110	130	115	6.5	M8x20	38	50
110B	14	15	15.875	16	19	22	24	-	-	110	145	120	6.5	M8x20	38	50
110B1	14	15	15.875	16	19	22	24	28	-	110	145	120	6.5	M8x20	48	60
130A	14	15	15.875	16	19	22	24	-	-	130	165	140	6.5	M10x20	38	50
130A1	14	15	15.875	16	19	22	24	28	32	130	165	140	6.5	M10x25	48	60

Please contact us for other motor adapters and input shaft bore.

LC 120

FM

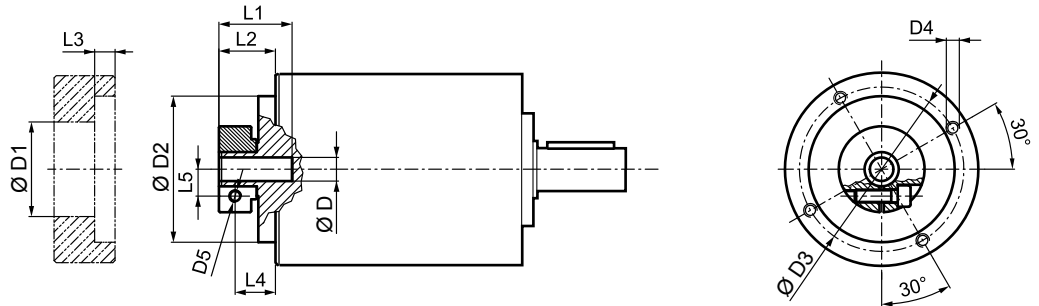

				D1	D2	D3	D4	D5	L1	L2	L3	L4	L5
14	15	15.875	16	48	90	98	M6x15	M6	33.5	20	7.6	12.5	14.5
19				51	90	98	M6x15	M6	33.5	20	7.6	12.5	16.5
22	24			56.5	90	98	M6x15	M6	36.5	23	7.6	14	19
28				67	90	98	M6x15	M8	36.5	23	7.6	14	22.5
32				71	90	98	M6x15	M8	38	24.5	7.6	15.5	24.5

	i	M _{n 2}	M _{a 2}	M _{p 2}	n ₁	n _{1 max}	φ _S	φ _R	C _t	R _{2 max}	A _{2 max}	η	J _G [kgcm ²]		
		[Nm]	[Nm]	[Nm]	[min ⁻¹]	[min ⁻¹]	[arcmin]	[Nm / arcmin]	[N]	[N]	%	14 ... 19	22 ; 24	28 ; 32	
LC 120 1_3		95	160	300	2500	3500	12'	6'	25	3500	3000	97	2.17	2.77	3.13
LC 120 1_4		110	190	360	2800	4500	12'	6'	25	3500	3000	97	1.30	1.89	2.26
LC 120 1_5		110	190	360	3000	4500	12'	6'	25	3500	3000	97	0.96	1.56	1.92
LC 120 1_7		110	190	360	3500	4500	12'	6'	25	3500	3000	97	0.66	1.26	1.62
LC 120 1_10		95	160	300	3500	5000	12'	6'	25	3500	3000	97	0.49	1.09	1.45
LC 120 2_9		95	160	300	2500	3500	15'	8'	22.5	3500	3000	94	1.61	2.20	2.57
LC 120 2_12		110	190	360	2500	3500	15'	8'	22.5	3500	3000	94	1.51	2.10	2.47
LC 120 2_15		110	190	360	2500	3500	15'	8'	22.5	3500	3000	94	1.47	2.06	2.43
LC 120 2_16		110	190	360	2800	4500	15'	8'	22.5	3500	3000	94	0.92	1.52	1.88
LC 120 2_20		110	190	360	3000	4500	15'	8'	22.5	3500	3000	94	0.90	1.50	1.86
LC 120 2_25		110	190	360	3000	4500	15'	8'	22.5	3500	3000	94	0.71	1.30	1.67
LC 120 2_28		110	190	360	3500	4500	15'	8'	22.5	3500	3000	94	0.54	1.13	1.50
LC 120 2_30		95	160	300	3500	5000	15'	8'	22.5	3500	3000	94	0.44	1.04	1.40
LC 120 2_35		110	190	360	3500	4500	15'	8'	22.5	3500	3000	94	0.53	1.13	1.49
LC 120 2_40		110	190	360	3500	5000	15'	8'	22.5	3500	3000	94	0.43	1.03	1.39
LC 120 2_50		110	190	360	3500	5000	15'	8'	22.5	3500	3000	94	0.43	1.02	1.39
LC 120 2_70		110	190	360	3500	5000	15'	8'	22.5	3500	3000	94	0.42	1.02	1.38
LC 120 2_100		95	160	300	3500	5000	15'	8'	22.5	3500	3000	94	0.42	1.02	1.38

S-M-BOR-NL-CAFS-001-V01

GT

LC 155

55A1 ... 180A1

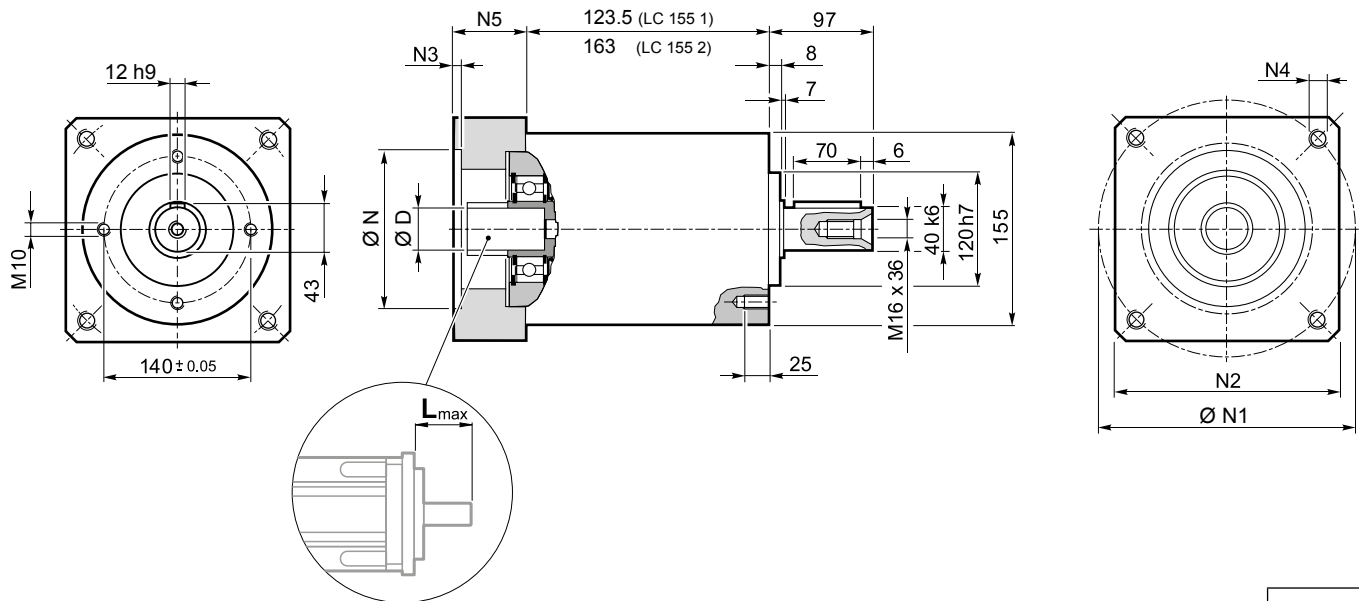

LC 155 1	19.3
LC 155 2	24.3

LC

								N	N1	N2	N3	N4	N5	L _{max}
55A1	19	-	-	-	-	-	-	55.5	125.7	130	4	M6x15	39.5	50
80A2	19	-	-	-	-	-	-	80	100	130	4	M6x15	39.5	50
95A1	19	22	24	-	-	-	-	95	115	130	4	M8x20	39.5	50
110A1	19	22	24	-	-	-	-	110	130	130	4	M8x20	39.5	50
110B1	19	22	24	-	-	-	-	110	145	130	6.5	M8x20	49.5	60
114A	19	22	24	28	32	35	38	114.3	200	170	5.5	M12x25	69.5	80
130A	19	22	24	-	-	-	-	130	165	140	4	M10x20	39.5	50
130A1	19	22	24	28	32	-	-	130	165	140	4	M10x20	49.5	60
180A	19	22	24	28	32	-	-	180	215	190	5.5	M14x25	49.5	60
180A1	19	22	24	28	32	35	38	180	215	190	5.5	M14x25	69.5	80



Please contact us for other motor adapters and input shaft bore.

LC 155

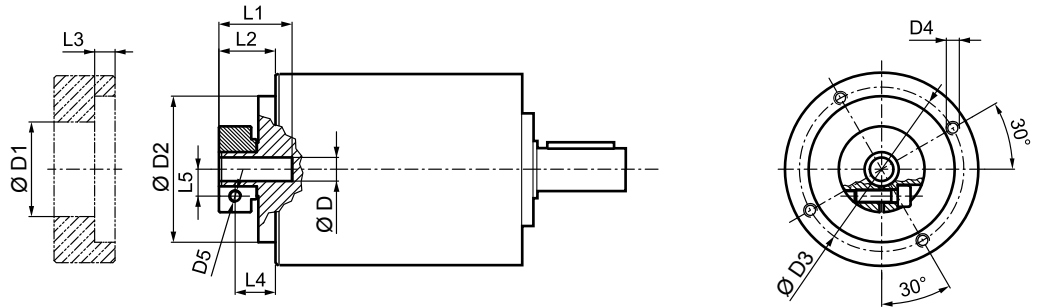
FM



	D1	D2	D3	D4	D5	L1	L2	L3	L4	L5
19	51	113	125.5	M8x15	M6	40	27.5	6	20	16.5
22 24	56.5	113	125.5	M8x15	M6	41	28.5	6	19.5	19
28	67	113	125.5	M8x15	M8	41	28.5	6	19.5	22.5
32	71	113	125.5	M8x15	M8	41	28.5	6	18.5	24.5
35	73	113	125.5	M8x15	M8	50	37.5	11.25	26	26
38	77.5	113	125.5	M8x15	M8	50	37.5	11.25	26	28

	i	M _{n 2} [Nm]	M _{a 2} [Nm]	M _{p 2} [Nm]	n ₁ [min ⁻¹]	n _{1 max} [min ⁻¹]	φ _S [arcmin]	φ _R [arcmin]	C _t [Nm/arcmin]	R _{2 max} [N]	A _{2 max} [N]	η %	J _G [kgcm ²]			
														19	22 ; 24	28 ; 32
LC 155 1 _ 3		250	380	600	2100	3600	12'	6'	43	6000	5000	97	7.99	8.19	8.54	9.90
LC 155 1 _ 4		300	450	700	2400	3600	12'	6'	43	6000	5000	97	4.66	4.87	5.23	6.57
LC 155 1 _ 5		300	450	900	2900	3600	12'	6'	43	6000	5000	97	3.32	3.53	3.88	5.23
LC 155 1 _ 7		300	450	900	3200	3600	12'	6'	43	6000	5000	97	2.14	2.35	2.70	4.05
LC 155 1 _ 10		230	350	750	3200	3600	12'	6'	43	6000	5000	97	1.45	1.66	2.01	3.36
LC 155 2 _ 9		250	380	600	2100	3600	15'	8'	37.5	6000	5000	94	5.30	5.51	5.86	7.21
LC 155 2 _ 12		300	450	700	2100	3600	15'	8'	37.5	6000	5000	94	4.93	5.14	5.49	6.84
LC 155 2 _ 15		300	450	900	2100	3600	15'	8'	37.5	6000	5000	94	4.79	4.99	5.34	6.70
LC 155 2 _ 16		300	450	700	2400	3600	15'	8'	37.5	6000	5000	94	2.97	3.18	3.53	4.88
LC 155 2 _ 20		300	450	900	2900	3600	15'	8'	37.5	6000	5000	94	2.23	2.44	2.79	4.14
LC 155 2 _ 25		300	450	900	2900	3600	15'	8'	37.5	6000	5000	94	2.18	2.39	2.74	4.09
LC 155 2 _ 28		300	450	900	3200	3600	15'	8'	37.5	6000	5000	94	1.58	1.79	2.14	3.49
LC 155 2 _ 30		250	380	600	3200	3600	15'	8'	37.5	6000	5000	94	1.23	1.44	1.79	3.14
LC 155 2 _ 35		300	450	900	3200	3600	15'	8'	37.5	6000	5000	94	1.55	1.76	2.11	3.46
LC 155 2 _ 40		300	450	700	3200	3600	15'	8'	37.5	6000	5000	94	1.20	1.41	1.76	3.11
LC 155 2 _ 50		300	450	900	3200	3600	15'	8'	37.5	6000	5000	94	1.19	1.39	1.74	3.10
LC 155 2 _ 70		300	450	900	3200	3600	15'	8'	37.5	6000	5000	94	1.17	1.38	1.73	3.08
LC 155 2 _ 100		230	350	750	3200	3600	15'	8'	37.5	6000	5000	94	1.17	1.38	1.73	3.08

LC 070P

25AH ... 80A

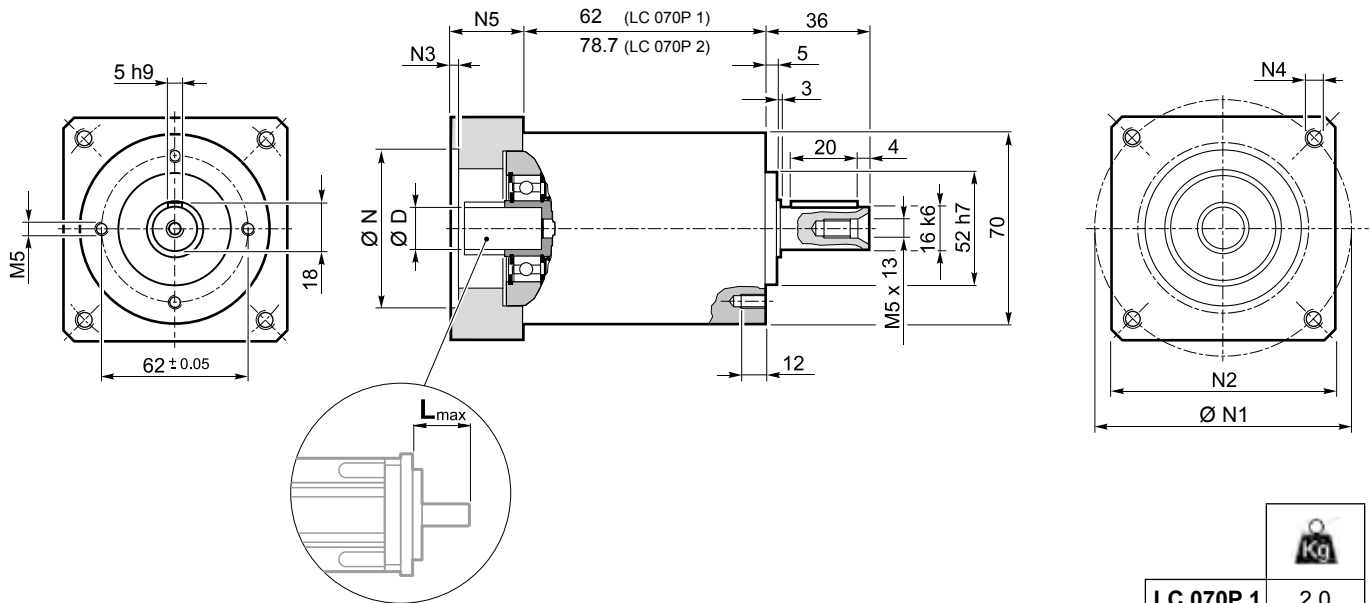

LC 070P 1	2.0
LC 070P 2	2.3

											N	N1		N2	N3	N4	N5	L _{max}
	D											min	max					
25AH	6.35	7	8	9	9.52	-	-	-	-	-	25	39	56					
26AH	6.35	7	8	9	9.52	-	-	-	-	-	26	39	56					
28AH	6.35	7	8	9	9.52	-	-	-	-	-	28	39	56					
30AH	6.35	7	8	9	9.52	-	-	-	-	-	30	39	56					
32AH	6.35	7	8	9	9.52	-	-	-	-	-	32	39	56	65	3.5	4.5	25	25
34AH	6.35	7	8	9	9.52	-	-	-	-	-	34	40	56					
36AH	6.35	7	8	9	9.52	-	-	-	-	-	36	42	56					
39AH	6.35	7	8	9	9.52	-	-	-	-	-	39	45	56					
40AH	6.35	7	8	9	9.52	-	-	-	-	-	40	46	56					
38B	6.35	7	8	9	9.52	10	11	12	12.7	-	38.1	66.6	60	3	M4x10	18	25	
40B	6.35	7	8	9	9.52	10	11	12	12.7	-	40	63	60	3	M4x10	18	25	
50A	6.35	7	8	9	9.52	10	11	12	12.7	-	50	60	60	3	M4x10	18	25	
50B	6.35	7	8	9	9.52	10	11	12	12.7	14	50	65	60	3	M5x12	23	30	
50BH	6.35	7	8	9	9.52	10	11	12	12.7	14	50	65	65	3	5.5	25	32	
50C	6.35	7	8	9	9.52	10	11	12	12.7	14	50	70	60	3	M4x10	23	30	
55MH	6.35	7	8	9	9.52	10	11	12	12.7	-	55	80	65	2	5.5	16	23	
60A	6.35	7	8	9	9.52	10	11	12	12.7	-	60	75	63	3	M5x12	18	25	
60A1	6.35	7	8	9	9.52	10	11	12	12.7	14	60	75	63	3	M5x12	23	30	
60B	6.35	7	8	9	9.52	10	11	12	12.7	14	60	85	75	3	M5x12	23	30	
60C	6.35	7	8	9	9.52	10	11	12	12.7	14	60	90	75	3	M5x12	23	30	
70A	6.35	7	8	9	9.52	10	11	12	12.7	14	70	85	75	3	M6x15	23	30	
70B	6.35	7	8	9	9.52	10	11	12	12.7	14	70	90	75	3	M5x12	23	30	
73A	6.35	7	8	9	9.52	10	11	12	12.7	14	73	98.4	85	3	M5x12	25	32	
80A	6.35	7	8	9	9.52	10	11	12	12.7	14	80	100	85	3	M6x15	23	30	

Please contact us for other motor adapters and input shaft bore.

LC 070P

FM

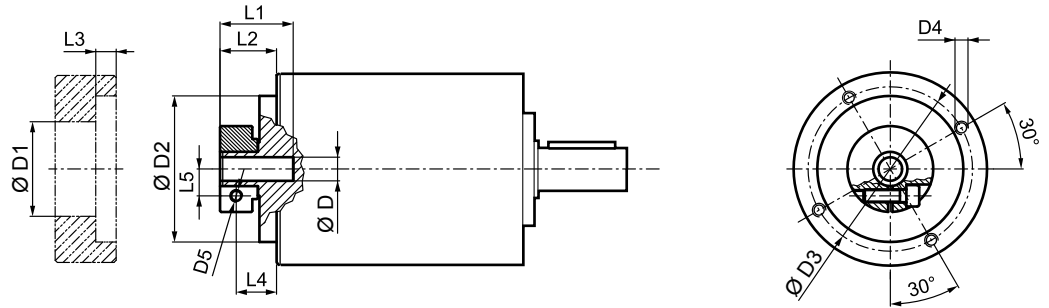

				D1	D2	D3	D4	D5	L1	L2	L3	L4	L5
6.35	7			32.5	50	42.5	M4x8	M4	21.7	13.2	3	8.2	8
8	9	9.52	10	32.5	50	42.5	M4x8	M4	21.7	13.2	3	8.2	9
11	12	12.7		35.5	50	42.5	M4x8	M4	22	13.5	3	8.5	11
14				35.5	50	42.5	M4x8	M4	25	17	3	10.2	11.5

	i	M _{n 2}	M _{a 2}	M _{p 2}	n ₁	n _{1 max}	φ _S	φ _R	C _t	R _{2 max}	A _{2 max}	η	J _G [kgcm ²]	
		[Nm]	[Nm]	[Nm]	[min ⁻¹]	[min ⁻¹]	[arcmin]	[arcmin]	$\frac{Nm}{arcmin}$	[N]	[N]	%		6 ... 9.52
LC 070P 1_3		29	55	60	3300	4000	12'	6'	3	1300	1400	97	0.12	0.14
LC 070P 1_4		30	45	70	3500	5000	12'	6'	3	1300	1400	97	0.08	0.10
LC 070P 1_5		25	40	70	3500	5000	12'	6'	3	1300	1400	97	0.06	0.09
LC 070P 1_7		25	40	70	4000	5000	12'	6'	3	1300	1400	97	0.05	0.07
LC 070P 1_10		18	30	60	4000	6000	12'	6'	3	3500	1400	97	0.04	0.06
LC 070P 2_9		29	55	60	3300	4000	15'	8'	2.5	1300	1400	94	0.11	0.13
LC 070P 2_12		29	55	70	3300	4000	15'	8'	2.5	1300	1400	94	0.10	0.13
LC 070P 2_15		29	55	70	3300	4000	15'	8'	2.5	1300	1400	94	0.10	0.12
LC 070P 2_16		30	45	70	3500	5000	15'	8'	2.5	1300	1400	94	0.07	0.09
LC 070P 2_20		30	45	70	3500	5000	15'	8'	2.5	1300	1400	94	0.06	0.08
LC 070P 2_25		30	45	70	3500	5000	15'	8'	2.5	1300	1400	94	0.06	0.08
LC 070P 2_28		30	45	70	4000	6000	15'	8'	2.5	1300	1400	94	0.05	0.07
LC 070P 2_30		29	55	60	4000	6000	15'	8'	2.5	1300	1400	94	0.04	0.06
LC 070P 2_35		30	45	70	4000	6000	15'	8'	2.5	1300	1400	94	0.05	0.07
LC 070P 2_40		30	45	70	4000	6000	15'	8'	2.5	1300	1400	94	0.04	0.06
LC 070P 2_50		30	45	70	4000	6000	15'	8'	2.5	1300	1400	94	0.04	0.06
LC 070P 2_70		30	45	70	4000	6000	15'	8'	2.5	1300	1400	94	0.04	0.06
LC 070P 2_100		18	30	60	4000	6000	15'	8'	2.5	1300	1400	94	0.04	0.06

S-M-BOR-NL-CAFS-001-V01

LC

LC 090P

40B1 ... 110B1

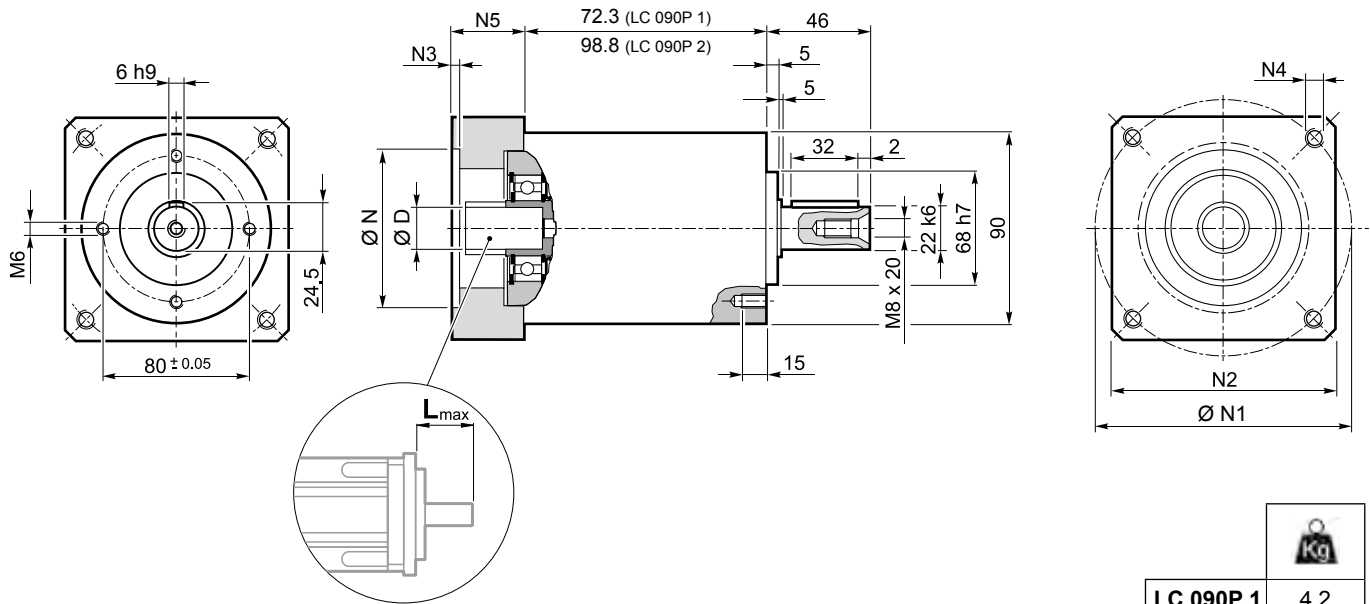

LC 090P 1	4.2
LC 090P 2	5.3

												N	N1	N2	N3	N4	N5	L _{max}
	9	9.52	11	12	12.7	14	-	-	-	-	-							
40B1	9	9.52	11	12	12.7	14	-	-	-	-	-	40	63	80	4	M4x10	34	40
45A	9	9.52	11	12	12.7	-	-	-	-	-	-	45	63	80	4	M4x10	34	40
50B1	9	9.52	11	12	12.7	14	-	-	-	-	-	50	65	80	4	M5x16	34	40
50BH1	9	9.52	11	12	12.7	14	-	-	-	-	-	50	65	80	4	5.5	34	40
50C1	9	9.52	11	12	12.7	14	-	-	-	-	-	50	70	80	4	M4x10	34	40
50D	9	9.52	11	12	12.7	14	-	-	-	-	-	50	95	80	4	M6x10	34	40
55A	9	9.52	11	12	12.7	14	15.875	16	17	19	19.05	55.5	125.7	105	4	M6x16	34	40
60A2	9	9.52	11	12	12.7	14	-	-	-	-	-	60	75	80	4	M5x16	34	40
60AH2	9	9.52	11	12	12.7	14	-	-	-	-	-	60	75	90	4	5.5	34	40
60B1	9	9.52	11	12	12.7	14	15.875	16	-	-	-	60	85	80	4	M5x16	34	40
60C1	9	9.52	11	12	12.7	14	15.875	16	-	-	-	60	90	80	4	M5x16	34	40
70A1	9	9.52	11	12	12.7	14	15.875	16	17	19	19.05	70	85	80	4	M6x20	34	40
70AH1	9	9.52	11	12	12.7	14	15.875	16	17	19	19.05	70	85	90	4	6.5	34	40
70B1	9	9.52	11	12	12.7	14	15.875	16	17	19	19.05	70	90	80	4	M5x16	34	40
73A1	9	9.52	11	12	12.7	14	-	-	-	-	-	73	98.4	85	4	M5x16	34	40
80A1	9	9.52	11	12	12.7	14	15.875	16	17	19	19.05	80	100	90	4	M6x16	34	40
95A	9	9.52	11	12	12.7	14	15.875	16	17	19	19.05	95	115	100	4	M8x20	34	40
95B	9	9.52	11	12	12.7	14	15.875	16	17	19	19.05	95	130	115	4	M8x20	34	40
110A	9	9.52	11	12	12.7	14	15.875	16	17	19	19.05	110	130	115	4	M8x20	34	40
110B	9	9.52	11	12	12.7	14	15.875	16	17	19	19.05	110	145	120	6.5	M8x20	44	50
110B1	9	9.52	11	12	12.7	14	15.875	16	17	19	19.05	110	145	120	6.5	M8x20	54	60

Please contact us for other motor adapters and input shaft bore.

LC 090P

FM

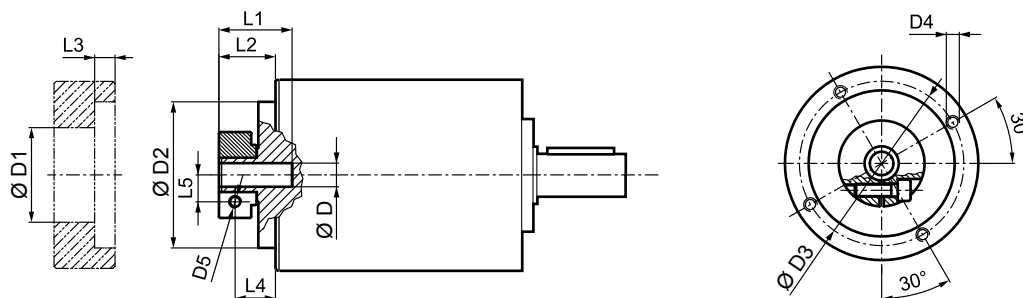

		D1	D2	D3	D4	D5	L1	L2	L3	L4	L5
9	9.52	38	68	76.5	M6x10	M6	34	26.8	9.5	18.8	10.5
11	12 12.7	43	68	76.5	M6x10	M6	34	26.8	9.5	18.8	12.5
14	15.875 16 17	48	68	76.5	M6x10	M6	34	26.8	9.5	18.8	14.5
19	19.05	51	68	76.5	M6x10	M6	34	26.8	9.5	18.8	16.5

	i	M _{n 2}	M _{a 2}	M _{p 2}	n ₁	n _{1 max}	φ _S	φ _R	C _t	R _{2 max}	A _{2 max}	η	J _G [kgcm ²]	
		[Nm]	[Nm]	[Nm]	[min ⁻¹]	[min ⁻¹]	[arcmin]	[Nm/arcmin]	[N]	[N]	%	8 ... 12.7	14 ... 19	
LC 090P 1_3		65	120	150	3500	4000	12'	6'	12	2200	1900	97	0.62	0.77
LC 090P 1_4		60	110	160	3500	4000	12'	6'	12	2200	1900	97	0.41	0.55
LC 090P 1_5		50	100	160	3200	4500	12'	6'	9	2200	1900	97	0.33	0.47
LC 090P 1_7		50	100	160	4000	6000	12'	6'	9	2200	1900	97	0.26	0.40
LC 090P 1_10		40	70	150	4000	6000	12'	6'	9	2200	1900	97	0.21	0.35
LC 090P 2_9		65	120	150	3500	3500	15'	8'	12	2200	1900	94	0.47	0.61
LC 090P 2_12		65	120	160	3500	3500	15'	8'	12	2200	1900	94	0.44	0.58
LC 090P 2_15		65	120	160	3500	3500	15'	8'	12	2200	1900	94	0.43	0.57
LC 090P 2_16		60	110	160	3500	4500	15'	8'	12	2200	1900	94	0.31	0.45
LC 090P 2_20		60	110	160	3500	4500	15'	8'	12	2200	1900	94	0.26	0.40
LC 090P 2_25		50	100	160	3200	4500	15'	8'	9	2200	1900	94	0.26	0.40
LC 090P 2_28		50	100	160	4000	6000	15'	8'	9	2200	1900	94	0.22	0.36
LC 090P 2_30		65	120	150	4000	6000	15'	8'	12	2200	1900	94	0.20	0.34
LC 090P 2_35		50	100	160	4000	6000	15'	8'	9	2200	1900	94	0.22	0.36
LC 090P 2_40		60	110	160	4000	6000	15'	8'	12	2200	1900	94	0.20	0.34
LC 090P 2_50		50	100	160	4000	6000	15'	8'	9	2200	1900	94	0.20	0.34
LC 090P 2_70		50	100	160	4000	6000	15'	8'	9	2200	1900	94	0.20	0.34
LC 090P 2_100		40	70	150	4000	6000	15'	8'	9	2200	1900	94	0.19	0.34

S-M-BOR-NL-CAFS-001-V01

LC

LC 120P

50D ... 130A1

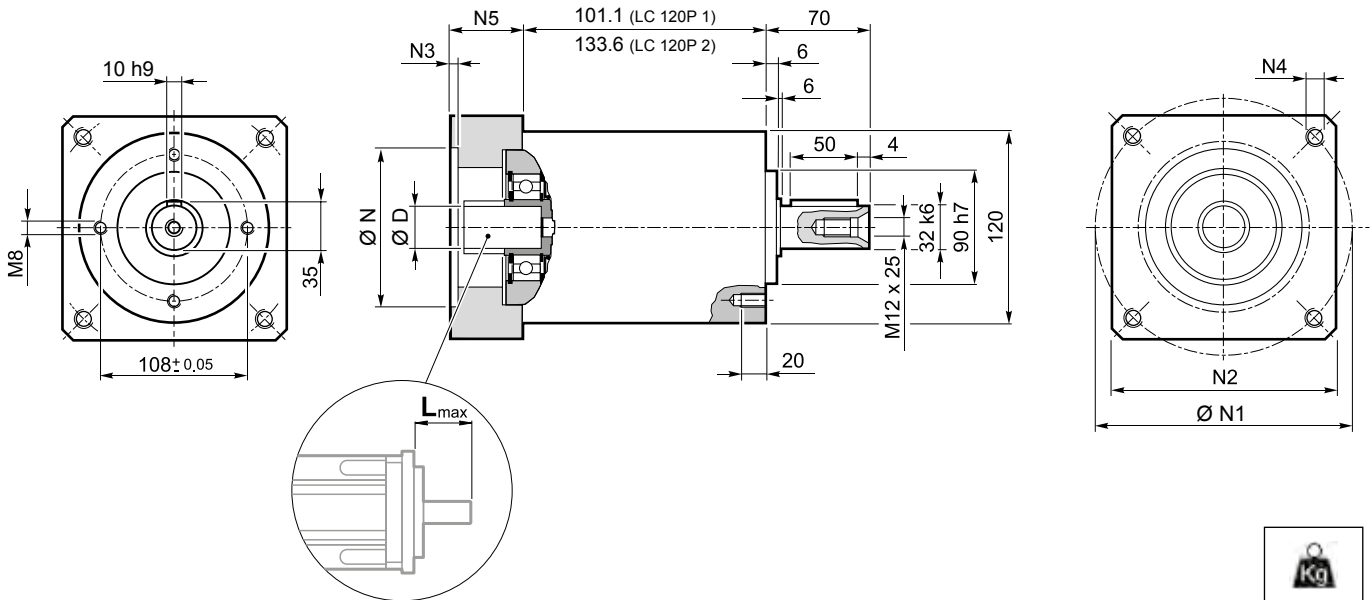

LC 120P 1	9.6
LC 120P 2	12.1

										N	N1	N2	N3	N4	N5	L _{max}
50D	14	15	15.875	16	19	-	-	-	-	50	95	100	5	M6x14	28	40
55A	14	15	15.875	16	19	-	-	-	-	55.5	125.7	105	5	M6x16	28	40
60A2	14	15	15.875	16	19	-	-	-	-	60	75	100	5	M5x14	28	40
60AH2	14	15	15.875	16	19	-	-	-	-	60	75	100	5	6.5	33	40
60B1	14	15	15.875	16	19	-	-	-	-	60	85	100	6.5	M5x14	28	40
70A1	14	15	15.875	16	19	-	-	-	-	70	85	100	5	M6x14	28	40
70AH1	14	15	15.875	16	19	-	-	-	-	70	85	100	5	6	33	40
70B1	14	15	15.875	16	19	-	-	-	-	70	90	100	5	M5x12	28	40
80A1	14	15	15.875	16	19	-	-	-	-	80	100	100	5	M6x16	28	40
80AH1	14	15	15.875	16	19	-	-	-	-	80	100	100	5	6.5	28	40
95A	14	15	15.875	16	19	-	-	-	-	95	115	100	5	M8x18	28	40
95A1	14	15	15.875	16	19	22	24	-	-	95	115	100	5	M8x18	38	50
95B	14	15	15.875	16	19	-	-	-	-	95	130	115	5	M8x18	28	40
110A	14	15	15.875	16	19	-	-	-	-	110	130	115	5	M8x18	28	40
110A1	14	15	15.875	16	19	22	24	-	-	110	130	115	6.5	M8x20	38	50
110B	14	15	15.875	16	19	22	24	-	-	110	145	120	6.5	M8x20	38	50
110B1	14	15	15.875	16	19	22	24	28	-	110	145	120	6.5	M8x20	48	60
130A	14	15	15.875	16	19	22	24	-	-	130	165	140	6.5	M10x20	38	50
130A1	14	15	15.875	16	19	22	24	28	32	130	165	140	6.5	M10x25	48	60

Please contact us for other motor adapters and input shaft bore.

LC 120P

FM

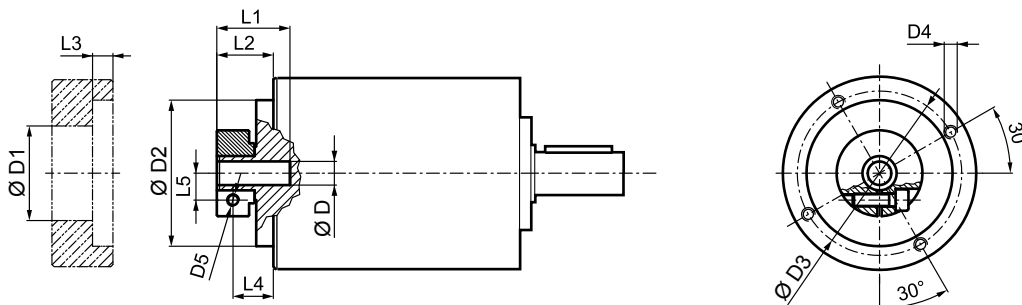

				D1	D2	D3	D4	D5	L1	L2	L3	L4	L5
14	15	15.875	16	48	90	98	M6x15	M6	33.5	20	7.6	12.5	14.5
19				51	90	98	M6x15	M6	33.5	20	7.6	12.5	16.5
22	24			56.5	90	98	M6x15	M6	36.5	23	7.6	14	19
28				67	90	98	M6x15	M8	36.5	23	7.6	14	22.5
32				71	90	98	M6x15	M8	38	24.5	7.6	15.5	24.5

	$M_n 2$	$M_a 2$	$M_p 2$	n_1	$n_1 \text{ max}$	φ_s	φ_R	C_t	$R_2 \text{ max}$	$A_2 \text{ max}$	η	$J_G \text{ [kgcm}^2\text{]}$		
												D	14 ... 19	22 ; 24
LC 120P 1_3	155	280	300	3000	4000	12'	6'	30	3500	3000	97	2.17	2.77	3.13
LC 120P 1_4	155	300	360	3000	4500	12'	6'	30	3500	3000	97	1.30	1.89	2.26
LC 120P 1_5	125	240	360	3000	4500	12'	6'	25	3500	3000	97	0.96	1.56	1.92
LC 120P 1_7	125	240	360	3500	4500	12'	6'	25	3500	3000	97	0.66	1.26	1.62
LC 120P 1_10	100	160	300	3500	5000	12'	6'	25	3500	3000	97	0.49	1.09	1.45
LC 120P 2_9	155	280	300	3000	4000	15'	8'	30	3500	3000	94	1.61	2.20	2.57
LC 120P 2_12	155	300	360	3000	4000	15'	8'	30	3500	3000	94	1.51	2.10	2.47
LC 120P 2_15	155	300	360	3000	4000	15'	8'	30	3500	3000	94	1.47	2.06	2.43
LC 120P 2_16	155	300	360	3000	4500	15'	8'	30	3500	3000	94	0.92	1.52	1.88
LC 120P 2_20	155	300	360	3000	4500	15'	8'	30	3500	3000	94	0.90	1.50	1.86
LC 120P 2_25	125	240	360	3000	4500	15'	8'	22.5	3500	3000	94	0.71	1.30	1.67
LC 120P 2_28	125	240	360	3500	5000	15'	8'	22.5	3500	3000	94	0.54	1.13	1.50
LC 120P 2_30	155	300	300	3500	5000	15'	8'	30	3500	3000	94	0.44	1.04	1.40
LC 120P 2_35	125	240	360	3500	5000	15'	8'	22.5	3500	3000	94	0.53	1.13	1.49
LC 120P 2_40	155	300	360	3500	5000	15'	8'	30	3500	3000	94	0.43	1.03	1.39
LC 120P 2_50	125	240	360	3500	5000	15'	8'	22.5	3500	3000	94	0.43	1.02	1.39
LC 120P 2_70	125	240	360	3500	5000	15'	8'	22.5	3500	3000	94	0.42	1.02	1.38
LC 120P 2_100	100	160	300	3500	5000	15'	8'	22.5	3500	3000	94	0.42	1.02	1.38

LC 155P

55A1 ... 180A1

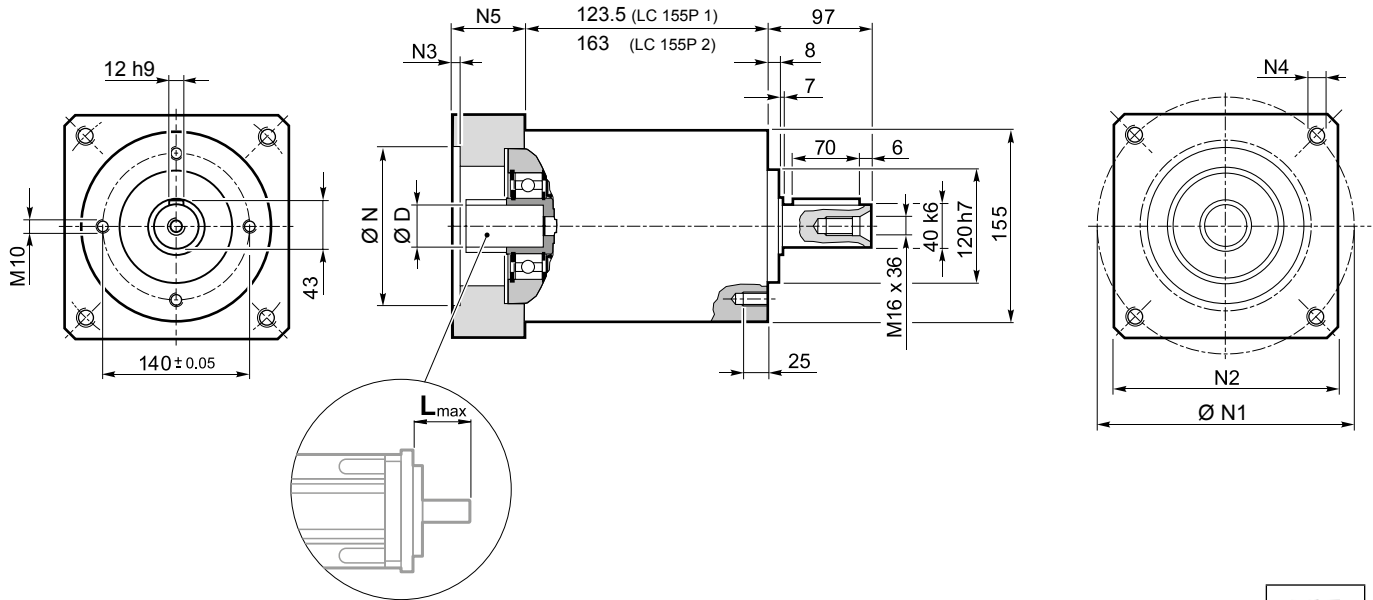

LC 155P 1	19.3
LC 155P 2	24.3

LC

			N	N1	N2	N3	N4	N5	L _{max}
55A1	19	- - - - -	55.5	125.7	130	4	M6x15	39.5	50
80A2	19	- - - - -	80	100	130	4	M6x15	39.5	50
95A1	19	22 24 - - - -	95	115	130	4	M8x20	39.5	50
110A1	19	22 24 - - - -	110	130	130	4	M8x20	39.5	50
110B1	19	22 24 - - - -	110	145	130	6.5	M8x20	49.5	60
114A	19	22 24 28 32 35 38	114.3	200	170	5.5	M12x25	69.5	80
130A	19	22 24 - - - -	130	165	140	4	M10x20	39.5	50
130A1	19	22 24 28 32 - - -	130	165	140	4	M10x20	49.5	60
180A	19	22 24 28 32 - - -	180	215	190	5.5	M14x25	49.5	60
180A1	19	22 24 28 32 35 38	180	215	190	5.5	M14x25	69.5	80



Please contact us for other motor adapters and input shaft bore.

LC 155P

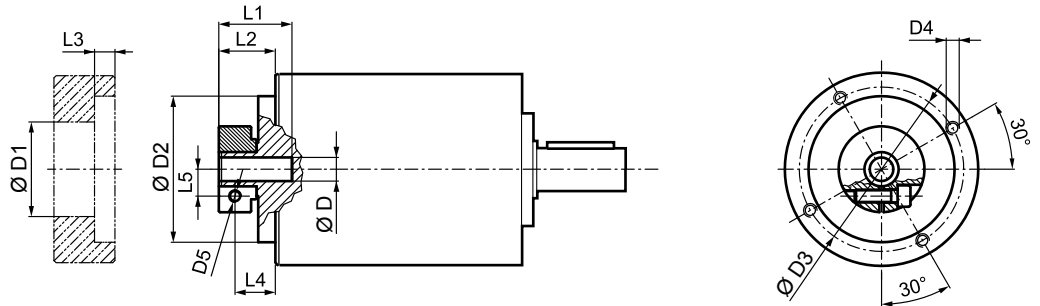
FM

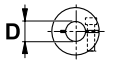

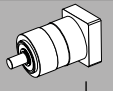
	D1	D2	D3	D4	D5	L1	L2	L3	L4	L5
19	51	113	125.5	M8x15	M6	40	27.5	6	20	16.5
22 24	56.5	113	125.5	M8x15	M6	41	28.5	6	19.5	19
28	67	113	125.5	M8x15	M8	41	28.5	6	19.5	22.5
32	71	113	125.5	M8x15	M8	41	28.5	6	18.5	24.5
35	73	113	125.5	M8x15	M8	50	37.5	11.25	26	26
38	77.5	113	125.5	M8x15	M8	50	37.5	11.25	26	28

	<i>i</i>	M_n 2 [Nm]	M_a 2 [Nm]	M_p 2 [Nm]	n_1 [min ⁻¹]	n_1 max [min ⁻¹]	φ_S [arcmin]	φ_R [arcmin]	C_t [Nm/arcmin]	R_2 max [N]	A_2 max [N]	η %	J_G [kgcm ²]			
														19	22 ; 24	28 ; 32
LC 155P 1_3		250	380	600	2100	3600	12'	6'	50	6000	5000	97	7.99	8.19	8.54	9.90
LC 155P 1_4		350	500	1000	2400	3600	12'	6'	50	6000	5000	97	4.66	4.87	5.23	6.57
LC 155P 1_5		350	500	1000	2900	3600	12'	6'	50	6000	5000	97	3.32	2.53	3.53	5.23
LC 155P 1_7		350	500	1000	3200	3600	12'	6'	50	6000	5000	97	2.14	2.35	2.70	4.05
LC 155P 1_10		230	350	750	3200	3600	12'	6'	50	6000	5000	97	1.14	1.66	2.01	3.36
LC 155P 2_9		250	380	600	2100	3600	15'	8'	48	6000	5000	94	5.30	5.51	5.86	7.21
LC 155P 2_12		450	700	1000	2100	3600	15'	8'	48	6000	5000	94	4.93	5.14	5.49	6.84
LC 155P 2_15		450	700	1000	2100	3600	15'	8'	48	6000	5000	94	4.79	4.99	5.34	6.70
LC 155P 2_16		450	700	1000	2400	3600	15'	8'	48	6000	5000	94	2.97	3.18	3.53	4.88
LC 155P 2_20		450	700	1000	2900	3600	15'	8'	48	6000	5000	94	2.23	2.44	2.79	4.14
LC 155P 2_25		450	700	1000	2900	3600	15'	8'	48	6000	5000	94	2.18	2.39	2.74	4.09
LC 155P 2_28		450	700	1000	3200	3600	15'	8'	48	6000	5000	94	1.58	1.79	2.14	3.49
LC 155P 2_30		250	380	750	3200	3600	15'	8'	48	6000	5000	94	1.23	1.44	1.79	3.14
LC 155P 2_35		450	700	1000	3200	3600	15'	8'	48	6000	5000	94	1.55	1.76	2.11	3.46
LC 155P 2_40		450	700	1000	3200	3600	15'	8'	48	6000	5000	94	1.20	1.41	1.76	3.11
LC 155P 2_50		450	700	1000	3200	3600	15'	8'	48	6000	5000	94	1.19	1.39	1.74	3.10
LC 155P 2_70		450	700	1000	3200	3600	15'	8'	48	6000	5000	94	1.17	1.38	1.73	3.08
LC 155P 2_100		230	350	750	3200	3600	15'	8'	48	6000	5000	94	1.17	1.38	1.73	3.08

S-M-BOR-NL-CAFS-001-V01

CT

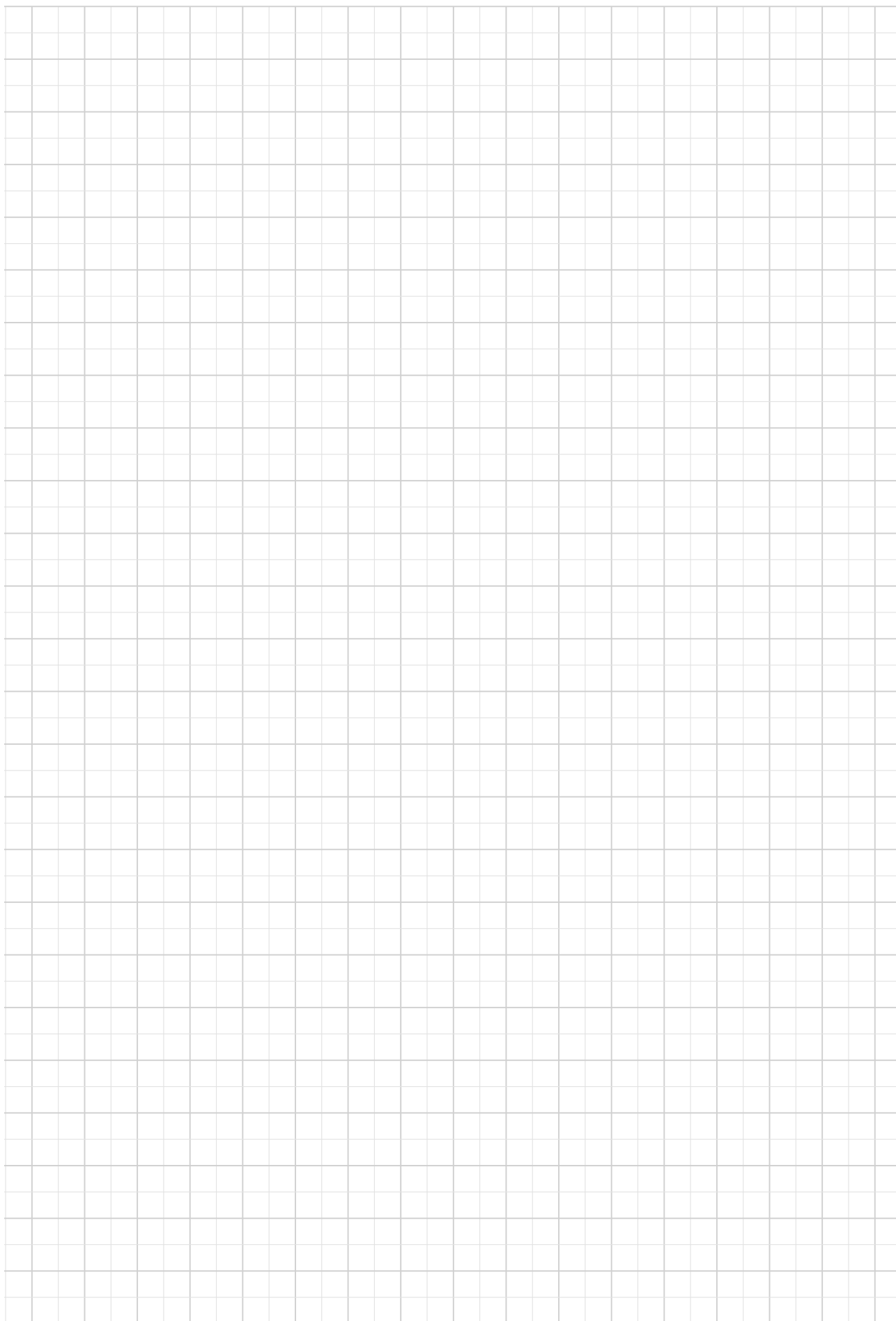

LC

LCK

PLANETARY PRECISION RIGHT ANGLE GEARBOX

LCK replicate in the right angle layout excellent features already typical of the inline products LC series. Right angle layout is the solution to space problems often posed by increasingly compact machines.

This serie represent a flexible solution, and economic alternative together with an optimal performance and reliability.

Improved Performance as the key to downsizing

Enhanced performance of our LCK precision gearbox (New "P" option) may open up important downsizing in many applications where previously was impossible to ensure a higher transmissible output torque. As an additional benefit, downsizing lead to an improvement of energy efficiency by selecting a more compact gearbox with higher torque density and reducing significantly the acceleration mass. Transmissible torque is now improved up to 40%.



Product Line Up:

- High Torque Density Option "P" available to extend Product Performance
- Optimal Acceleration and Nominal Torques
- Optimal Radial and Axial Load Capacities
- Designed for Cyclic and Continuous Duty
- Optimal Torsional Stiffness
- Geometrical Backlash less than 6 arcmin
- Universal Design allow any Mounting Orientation

8 FEATURES OF LCK SERIES

Gear units of series LCK replicate in the right angle layout the brilliant features that are already typical of the in-line products of the LC series, with the additional benefit of a facilitated installation in tight spaces.

- Available in one only backlash option, corresponding to following values:
2-stage units: standard $\varphi_S \leq 6'$;
3-stage units: standard $\varphi_S \leq 8'$;
- A high IP rating (IP64) provides inner parts with protection against the ingress of dust and liquids.
- Input section oil seals made from a Fluoroelastomer compound are supplied as standard.
- Noise pressure level $L_P \leq 70$ dB(A). Conditions: distance 1 m; measured without load an input speed of $n_1 = 3000 \text{ min}^{-1}$; $i=10$.
- Wide range of adapter flanges matching the most popular brands of motors
- Units are factory filled with synthetic grease to NLGI consistency class 00, in the absence of contamination the lubricant requires no periodical changes.
- Ambient temperature min -20°C , max $+30^\circ\text{C}$. For temperature higher than 30°C please consider derating factor f_T .
- Housing temperature must not exceed $T_{\text{max}} = 90^\circ\text{C}$.
- Available as Version P with higher output Torque.

		Distribution of nominal torque M_{n2} [Nm]											
	[i]	6	8	10	14	20	24	30	50	70	80	90	100
LCK 050	10	12	12	12	–	12	12	12	12	12	–	12	–
LCK 070	18	25	25	25	18	25	25	25	25	25	25	–	25
LCK 070P	25	30	25	25	18	29	29	30	30	30	30	–	30
LCK 090	37	43	43	43	37	43	43	43	43	43	43	–	43
LCK 090P	45	60	50	50	40	60	60	50	50	60	–	–	50
LCK 120	95	110	110	110	95	110	110	110	110	110	110	–	110
LCK 120P	110	140	125	125	100	155	155	125	125	155	–	–	125
LCK 155	250	300	300	300	230	300	300	300	300	300	300	–	300
LCK 155P	250	350	350	350	230	450	450	450	450	450	450	–	450

LCK

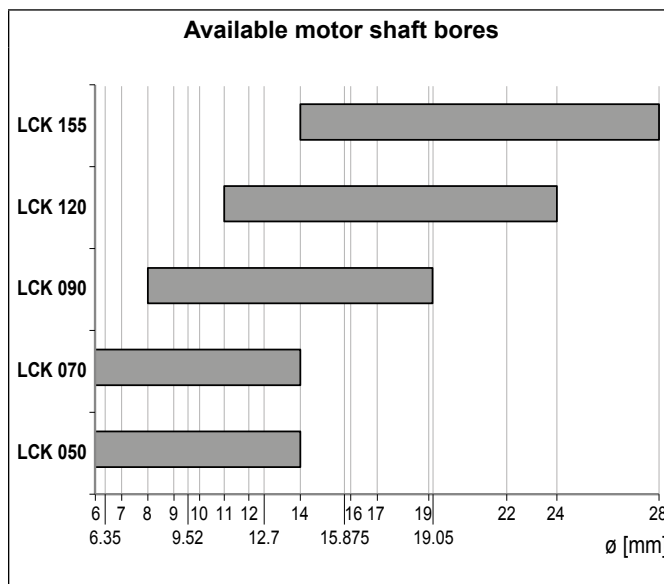
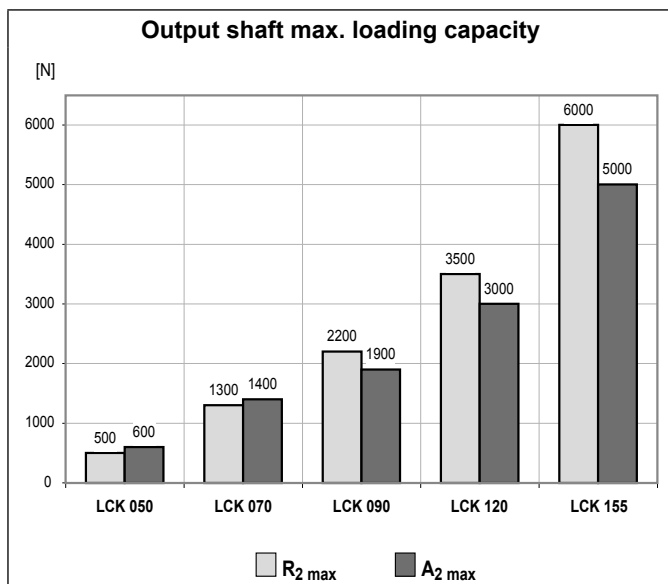

8.1 ORDERING CODE

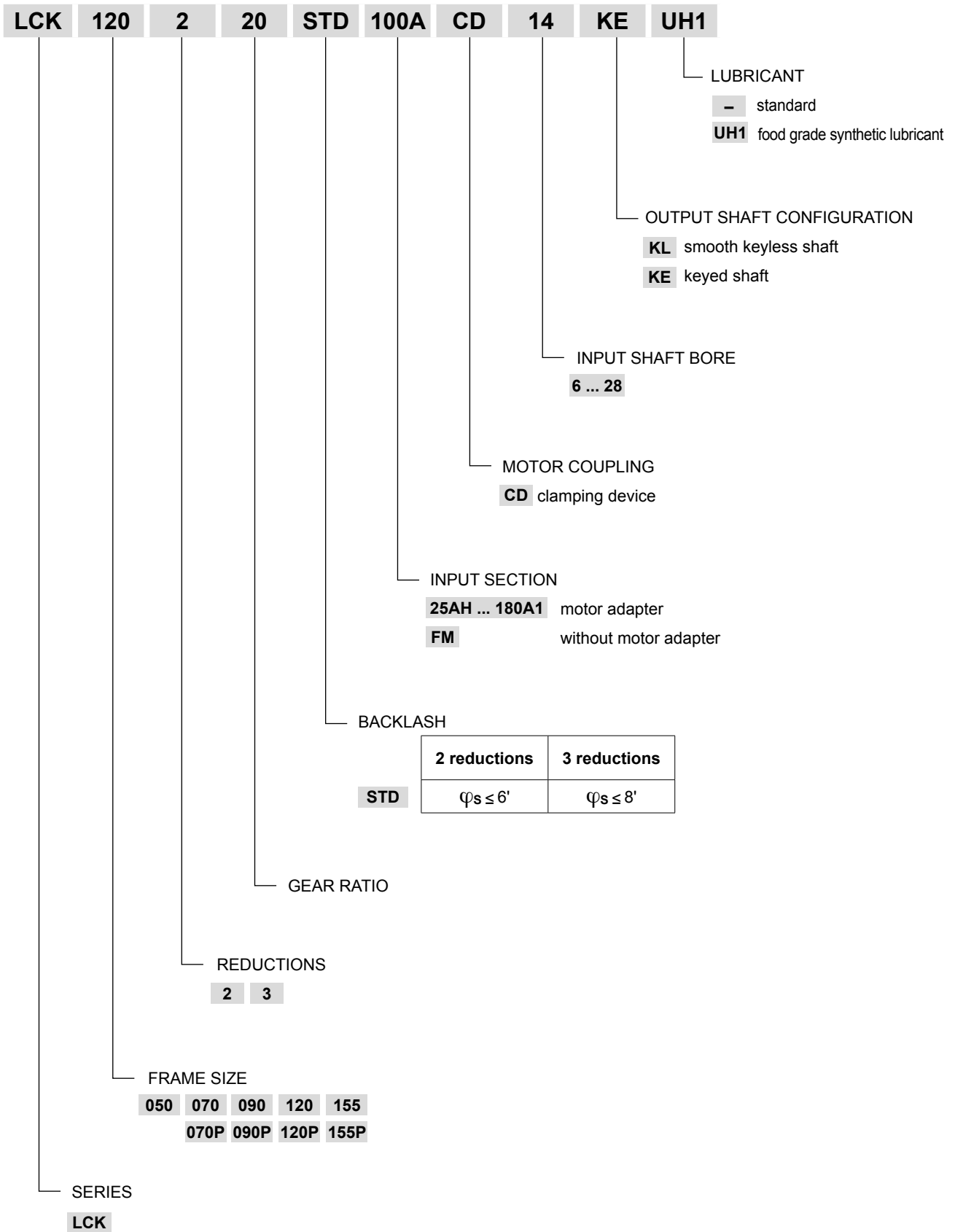

LCK

8.2 DIMENSIONS AND TECHNICAL SPECIFICATIONS

LCK 050

25AH ... 80A

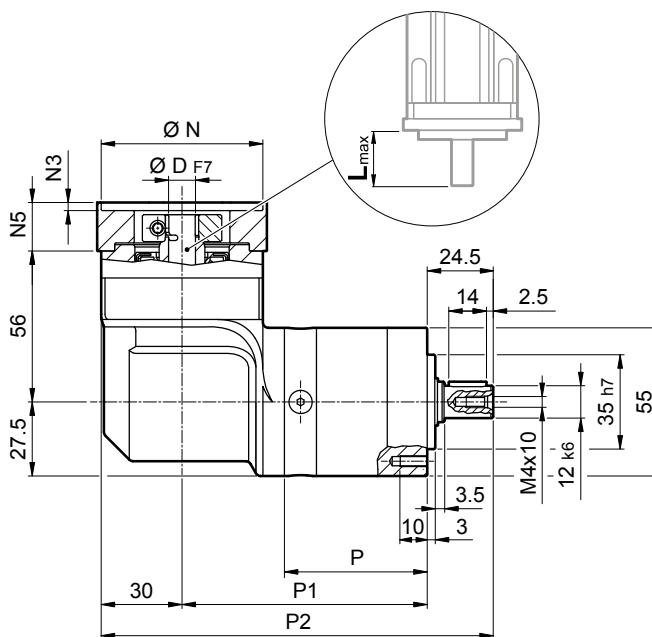
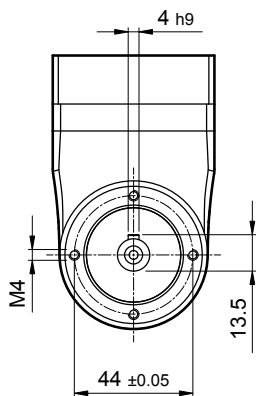

	P	P1	P2	
LCK 050 2	53	91	145.5	1.6
LCK 050 3	66.8	104.8	159.3	1.8

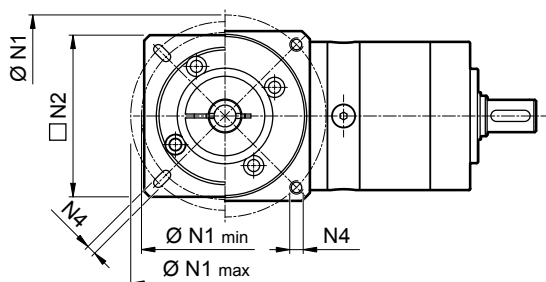

															N	N1		N2	N3	N4	N5	L _{max}
	D	6	6.35	7	8	9	9.52	10	11	12	12.7	14	min	max								
25AH	6	6.35	7	8	9	9.52	-	-	-	-	-	25	39	56								
26AH	6	6.35	7	8	9	9.52	-	-	-	-	-	26	39	56								
28AH	6	6.35	7	8	9	9.52	-	-	-	-	-	28	39	56								
30AH	6	6.35	7	8	9	9.52	-	-	-	-	-	30	39	56								
32AH	6	6.35	7	8	9	9.52	-	-	-	-	-	32	39	56	65	3.5	4.5	25	25			
34AH	6	6.35	7	8	9	9.52	-	-	-	-	-	34	40	56								
36AH	6	6.35	7	8	9	9.52	-	-	-	-	-	36	42	56								
38AH	6	6.35	7	8	9	9.52	-	-	-	-	-	39	45	56								
40AH	6	6.35	7	8	9	9.52	-	-	-	-	-	40	46	56								
38B	6	6.35	7	8	9	9.52	10	11	12	12.7	-	38.1	66.6	60	3	M4x10	18	25				
40B	6	6.35	7	8	9	9.52	10	11	12	12.7	-	40	63	60	3	M4x10	18	25				
50A	6	6.35	7	8	9	9.52	10	11	12	12.7	-	50	60	60	3	M4x10	18	25				
50B	6	6.35	7	8	9	9.52	10	11	12	12.7	14	50	65	60	3	M5x12	23	30				
50BH	6	6.35	7	8	9	9.52	10	11	12	12.7	14	50	65	65	3	5.5	25	32				
50C	6	6.35	7	8	9	9.52	10	11	12	12.7	14	50	70	60	3	M4x10	23	30				
50MH	6	6.35	7	8	9	9.52	10	11	12	12.7	-	55	80	65	2	5.5	16	23				
60A	6	6.35	7	8	9	9.52	10	11	12	12.7	-	60	75	63	3	M5x12	18	25				
60A1	6	6.35	7	8	9	9.52	10	11	12	12.7	14	60	75	63	3	M5x12	23	30				
60B	6	6.35	7	8	9	9.52	10	11	12	12.7	14	60	85	75	3	M5x12	23	30				
60C	6	6.35	7	8	9	9.52	10	11	12	12.7	14	60	90	75	3	M5x12	23	30				
70A	6	6.35	7	8	9	9.52	10	11	12	12.7	14	70	85	75	3	M6x15	23	30				
70B	6	6.35	7	8	9	9.52	10	11	12	12.7	14	70	90	75	3	M5x12	23	30				
73A	6	6.35	7	8	9	9.52	10	11	12	12.7	14	73	98.4	85	3	M5x12	25	32				
80A	6	6.35	7	8	9	9.52	10	11	12	12.7	14	80	100	85	3	M6x15	23	30				

Please contact us for other motor adapters and input shaft bore.

LCK

LCK 050

FM

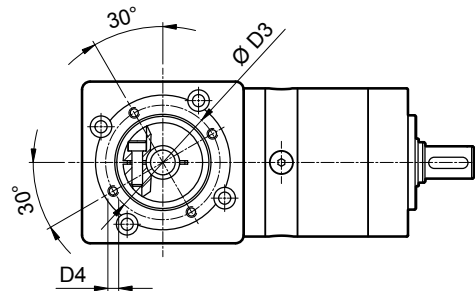
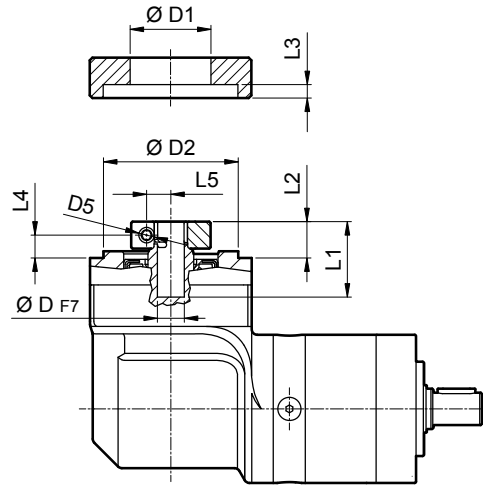
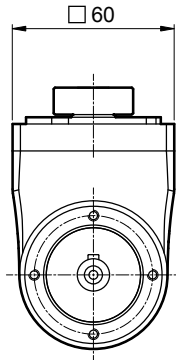

D			D1	D2	D3	D4	D5	L1	L2	L3	L4	L5
6	6.35	7	32.5	50	42.5	M4x8	M4	28	13.5	3	8.5	8
8	9	9.52	32.5	50	42.5	M4x8	M4	28	13.5	3	8.5	9
11	12	12.7	35.5	50	42.5	M4x8	M4	23	13.5	3	8.5	11
14			35.5	50	42.5	M4x8	M4	25	15.5	3	8.9	11.5

i	M _{n 2} [Nm]	M _{a 2} [Nm]	M _{p 2} [Nm]	n ₁ [min ⁻¹]	n _{1 max} [min ⁻¹]	φ _s [arcmin]	C _t [$\frac{Nm}{arcmin}$]	R _{2 max} [N]	A _{2 max} [N]	η %	J _G [kgm ²]	
											D	6 ... 9.52
LCK 050 2_6	10	16	28	2500	5000	6'	0.9	500	600	94	0.23	0.25
LCK 050 2_8	12	20	30	2500	5000	6'	0.9	500	600	94	0.23	0.24
LCK 050 2_10	12	20	30	2500	5000	6'	0.9	500	600	94	0.23	0.24
LCK 050 2_14	12	20	30	2500	5000	6'	0.9	500	600	94	0.23	0.24
LCK 050 3_24	12	20	30	2500	5000	8'	0.7	500	600	91	0.23	0.25
LCK 050 3_30	12	20	30	2500	5000	8'	0.7	500	600	91	0.23	0.25
LCK 050 3_50	12	20	30	2500	5000	8'	0.7	500	600	91	0.23	0.24
LCK 050 3_70	12	20	30	2500	5000	8'	0.7	500	600	91	0.23	0.24
LCK 050 3_90	12	20	30	2500	5000	8'	0.7	500	600	91	0.22	0.24

LCK

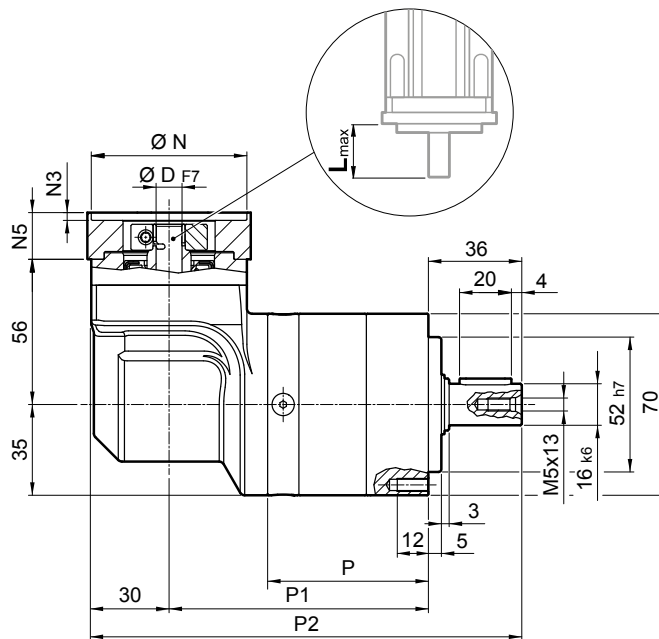
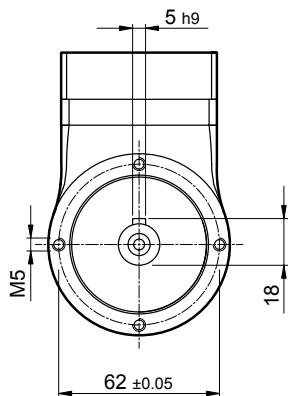

LCK 070

25AH ... 80A

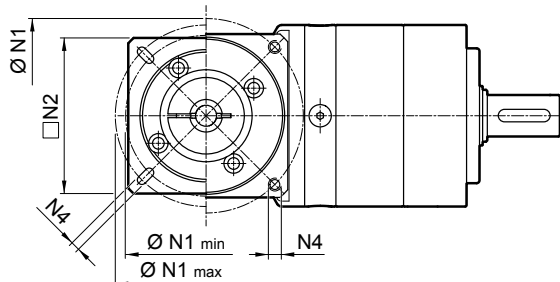

	P	P1	P2	
LCK 070 2	62	100	166	2.7
LCK 070 3	78.7	116.7	182.7	3.0



											N	N1		N2	N3	N4	N5	L _{max}	
	D	6	6.35	7	8	9	9.52	10	11	12		12.7	14						min
25AH	6	6.35	7	8	9	9.52	-	-	-	-	-	25	39	56					
26AH	6	6.35	7	8	9	9.52	-	-	-	-	-	26	39	56					
28AH	6	6.35	7	8	9	9.52	-	-	-	-	-	28	39	56					
30AH	6	6.35	7	8	9	9.52	-	-	-	-	-	30	39	56					
32AH	6	6.35	7	8	9	9.52	-	-	-	-	-	32	39	56	65	3.5	4.5	25	25
34AH	6	6.35	7	8	9	9.52	-	-	-	-	-	34	40	56					
36AH	6	6.35	7	8	9	9.52	-	-	-	-	-	36	42	56					
39AH	6	6.35	7	8	9	9.52	-	-	-	-	-	39	45	56					
40AH	6	6.35	7	8	9	9.52	-	-	-	-	-	40	46	56					
38B	6	6.35	7	8	9	9.52	10	11	12	12.7	-	38.1	66.6	60	3	M4x10	18	25	
40B	6	6.35	7	8	9	9.52	10	11	12	12.7	-	40	63	60	3	M4x10	18	25	
50A	6	6.35	7	8	9	9.52	10	11	12	12.7	-	50	60	60	3	M4x10	18	25	
50B	6	6.35	7	8	9	9.52	10	11	12	12.7	14	50	65	60	3	M5x12	23	30	
50BH	6	6.35	7	8	9	9.52	10	11	12	12.7	14	50	65	65	3	5.5	25	32	
50C	6	6.35	7	8	9	9.52	10	11	12	12.7	14	50	70	60	3	M4x10	23	30	
55MH	6	6.35	7	8	9	9.52	10	11	12	12.7	-	55	80	65	2	5.5	16	23	
60A	6	6.35	7	8	9	9.52	10	11	12	12.7	-	60	75	63	3	M5x12	18	25	
60A1	6	6.35	7	8	9	9.52	10	11	12	12.7	14	60	75	63	3	M5x12	23	30	
60B	6	6.35	7	8	9	9.52	10	11	12	12.7	14	60	85	75	3	M5x12	23	30	
60C	6	6.35	7	8	9	9.52	10	11	12	12.7	14	60	90	75	3	M5x12	23	30	
70A	6	6.35	7	8	9	9.52	10	11	12	12.7	14	70	85	75	3	M6x15	23	30	
70B	6	6.35	7	8	9	9.52	10	11	12	12.7	14	70	90	75	3	M5x12	23	30	
73A	6	6.35	7	8	9	9.52	10	11	12	12.7	14	73	98.4	85	3	M5x12	25	32	
80A	6	6.35	7	8	9	9.52	10	11	12	12.7	14	80	100	85	3	M6x15	23	30	

Please contact us for other motor adapters and input shaft bore.

LCK

LCK 070

FM

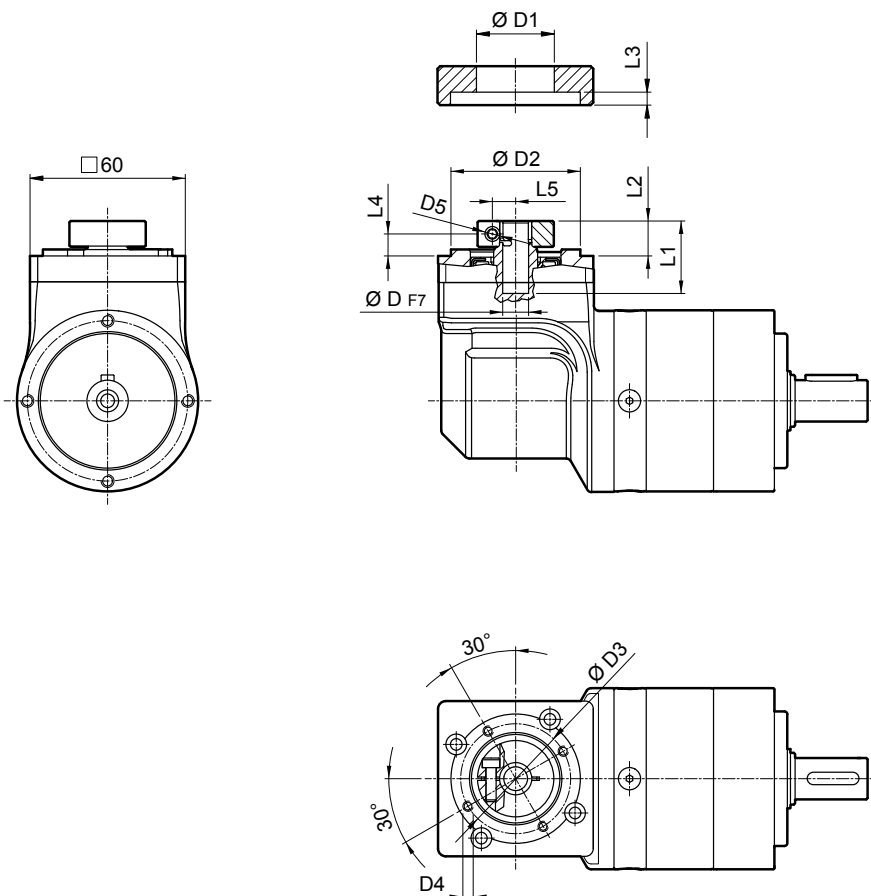

				D1	D2	D3	D4	D5	L1	L2	L3	L4	L5
6	6.35	7		32.5	50	42.5	M4x8	M4	28	13.5	3	8.5	8
8	9	9.52	10	32.5	50	42.5	M4x8	M4	28	13.5	3	8.5	9
11	12	12.7		35.5	50	42.5	M4x8	M4	23	13.5	3	8.5	11
14				35.5	50	42.5	M4x8	M4	25	15.5	3	8.9	11.5

	i	M _{n2}	M _{a2}	M _{p2}	n ₁	n _{1 max}	φ _s	C _t	R _{2 max}	A _{2 max}	η	J _c [kgcm ²]	
		[Nm]	[Nm]	[Nm]	[min ⁻¹]	[min ⁻¹]	[arcmin]	$\frac{Nm}{arcmin}$	[N]	[N]		%	
LCK 070 2_6		18	30	45	2500	5000	6'	2.8	1300	1400	94	0.25	0.26
LCK 070 2_8		25	35	60	2500	5000	6'	2.8	1300	1400	94	0.24	0.25
LCK 070 2_10		25	35	70	2500	5000	6'	2.8	1300	1400	94	0.23	0.25
LCK 070 2_14		25	35	70	2500	5000	6'	2.8	1300	1400	94	0.23	0.24
LCK 070 2_20		18	30	60	2500	5000	6'	2.8	1300	1400	94	0.23	0.24
LCK 070 3_24		25	35	70	2500	5000	8'	2.5	1300	1400	91	0.24	0.26
LCK 070 3_30		25	35	70	2500	5000	8'	2.5	1300	1400	91	0.24	0.26
LCK 070 3_50		25	35	70	2500	5000	8'	2.5	1300	1400	91	0.23	0.24
LCK 070 3_70		25	35	70	2500	5000	8'	2.5	1300	1400	91	0.23	0.24
LCK 070 3_80		25	35	70	2500	5000	8'	2.5	1300	1400	91	0.23	0.24
LCK 070 3_100		25	35	70	2500	5000	8'	2.5	1300	1400	91	0.23	0.24

LCK

LCK 090

40B1 ... 110B1

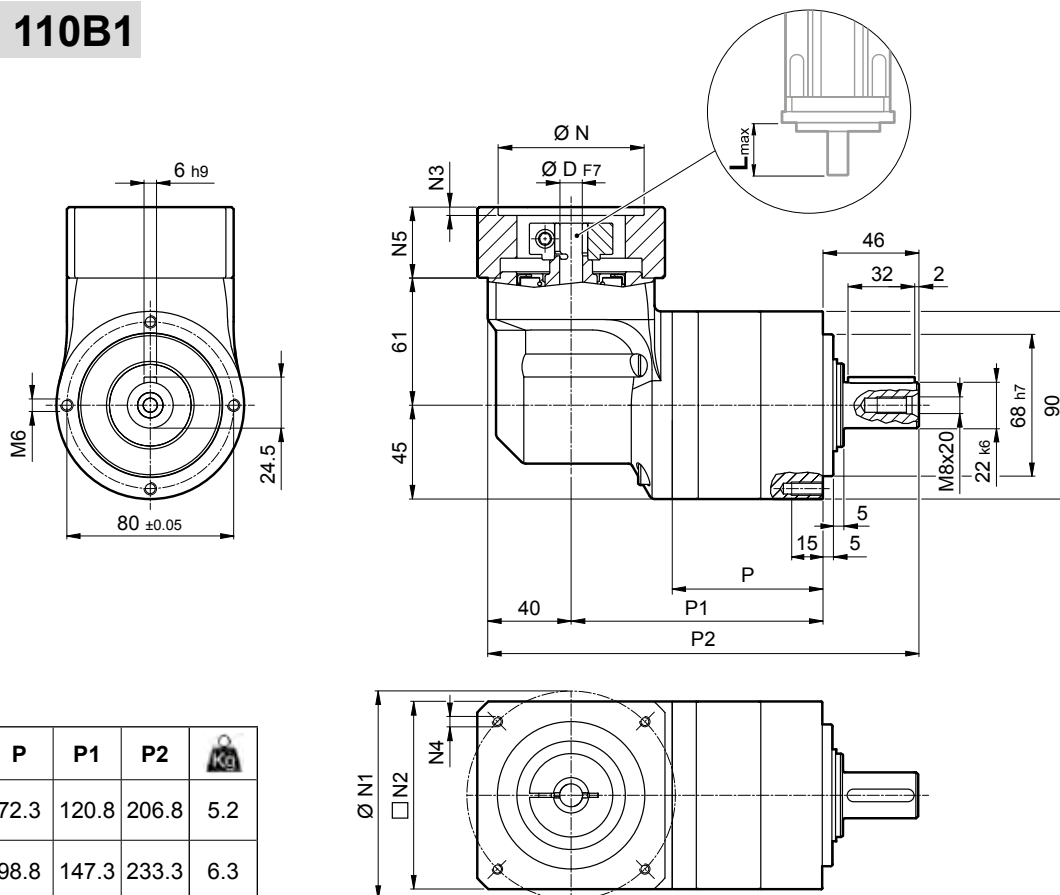

											N	N1	N2	N3	N4	N5	L _{max}		
	D	N1	N2	N3	N4	N5													
40B1	8	9	9.52	11	12	12.7	14	-	-	-	-	40	63	80	4	M4x10	34	40	
45A	8	9	9.52	11	12	12.7	-	-	-	-	-	45	63	80	4	M4x10	34	40	
50B1	8	9	9.52	11	12	12.7	14	-	-	-	-	50	65	80	4	M5x16	34	40	
50BH1	8	9	9.52	11	12	12.7	14	-	-	-	-	50	65	80	4	5.5	34	40	
50C1	8	9	9.52	11	12	12.7	14	-	-	-	-	50	70	80	4	M4x10	34	40	
50D	8	9	9.52	11	12	12.7	14	-	-	-	-	50	95	80	4	M6x10	34	40	
55A	8	9	9.52	11	12	12.7	14	15.875	16	17	19	19.05	55.5	125.7	105	4	M6x16	34	40
60A2	8	9	9.52	11	12	12.7	14	-	-	-	-	60	75	80	4	M5x16	34	40	
60AH2	8	9	9.52	11	12	12.7	14	-	-	-	-	60	75	90	4	5.5	34	40	
60B1	8	9	9.52	11	12	12.7	14	15.875	16	-	-	60	85	80	4	M5x16	34	40	
60C1	8	9	9.52	11	12	12.7	14	15.875	16	-	-	60	90	80	4	M5x16	34	40	
70A1	8	9	9.52	11	12	12.7	14	15.875	16	17	19	19.05	70	85	80	4	M6x20	34	40
70AH1	8	9	9.52	11	12	12.7	14	15.875	16	17	19	19.05	70	85	90	4	6.5	34	40
70B1	8	9	9.52	11	12	12.7	14	15.875	16	17	19	19.05	70	90	80	4	M5x16	34	40
73A1	8	9	9.52	11	12	12.7	14	-	-	-	-	73	98.4	85	4	M5x16	34	40	
80A1	8	9	9.52	11	12	12.7	14	15.875	16	17	19	19.05	80	100	90	4	M6x16	34	40
95A	8	9	9.52	11	12	12.7	14	15.875	16	17	19	19.05	95	115	100	4	M8x20	34	40
95B	8	9	9.52	11	12	12.7	14	15.875	16	17	19	19.05	95	130	115	4	M8x20	34	40
110A	8	9	9.52	11	12	12.7	14	15.875	16	17	19	19.05	110	130	115	4	M8x20	34	40
110B	8	9	9.52	11	12	12.7	14	15.875	16	17	19	19.05	110	145	120	6.5	M8x20	44	50
110B1	8	9	9.52	11	12	12.7	14	15.875	16	17	19	19.05	110	145	120	6.5	M8x20	54	60

Please contact us for other motor adapters and input shaft bore.

LCK 090

FM

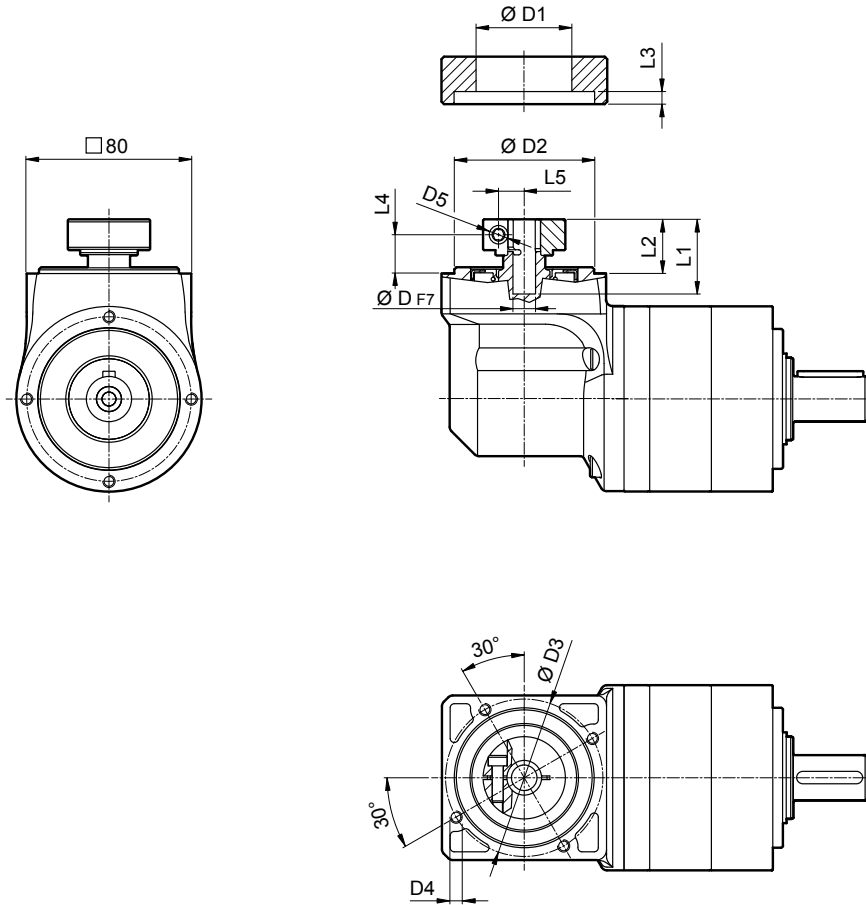

D				D1	D2	D3	D4	D5	L1	L2	L3	L4	L5
8	9	9.52		38	68	76.5	M6x10	M6	36.3	26.3	9.5	18.8	10.5
11	12	12.7		43	68	76.5	M6x10	M6	36.3	26.3	9.5	18.8	12.5
14	15.875	16	17	48	68	76.5	M6x10	M6	36.3	26.3	9.5	18.8	14.5
19	19.05			51	68	76.5	M6x10	M6	36.3	26.3	9.5	18.8	16.5

 i	M _{n 2}	M _{a 2}	M _{p 2}	n ₁	n _{1 max}	φ _s	C _t	R _{2 max}	A _{2 max}	η	J _G [kgcm ²]	
	[Nm]	[Nm]	[Nm]	[min ⁻¹]	[min ⁻¹]	[arcmin]	$\frac{Nm}{arcmin}$	[N]	[N]	%	8 ... 12.7	14 ... 19.05
LCK 090 2_6	37	63	90	2500	5000	6'	8	2200	1900	94	0.85	1.03
LCK 090 2_8	43	80	120	2500	5000	6'	8	2200	1900	94	0.79	0.98
LCK 090 2_10	43	80	150	2500	5000	6'	8	2200	1900	94	0.77	0.96
LCK 090 2_14	43	80	160	2500	5000	6'	8	2200	1900	94	0.75	0.94
LCK 090 2_20	37	70	150	2500	5000	6'	8	2200	1900	94	0.74	0.93
LCK 090 3_24	43	80	160	2500	5000	8'	7.8	2200	1900	91	0.81	1.00
LCK 090 3_30	43	80	160	2500	5000	8'	7.8	2200	1900	91	0.81	1.00
LCK 090 3_50	43	80	160	2500	5000	8'	7.8	2200	1900	91	0.76	0.94
LCK 090 3_70	43	80	160	2500	5000	8'	7.8	2200	1900	91	0.74	0.93
LCK 090 3_80	43	80	160	2500	5000	8'	7.8	2200	1900	91	0.74	0.93
LCK 090 3_100	43	80	160	2500	5000	8'	7.8	2200	1900	91	0.74	0.93

LCK

LCK 120

50D ... 130A1

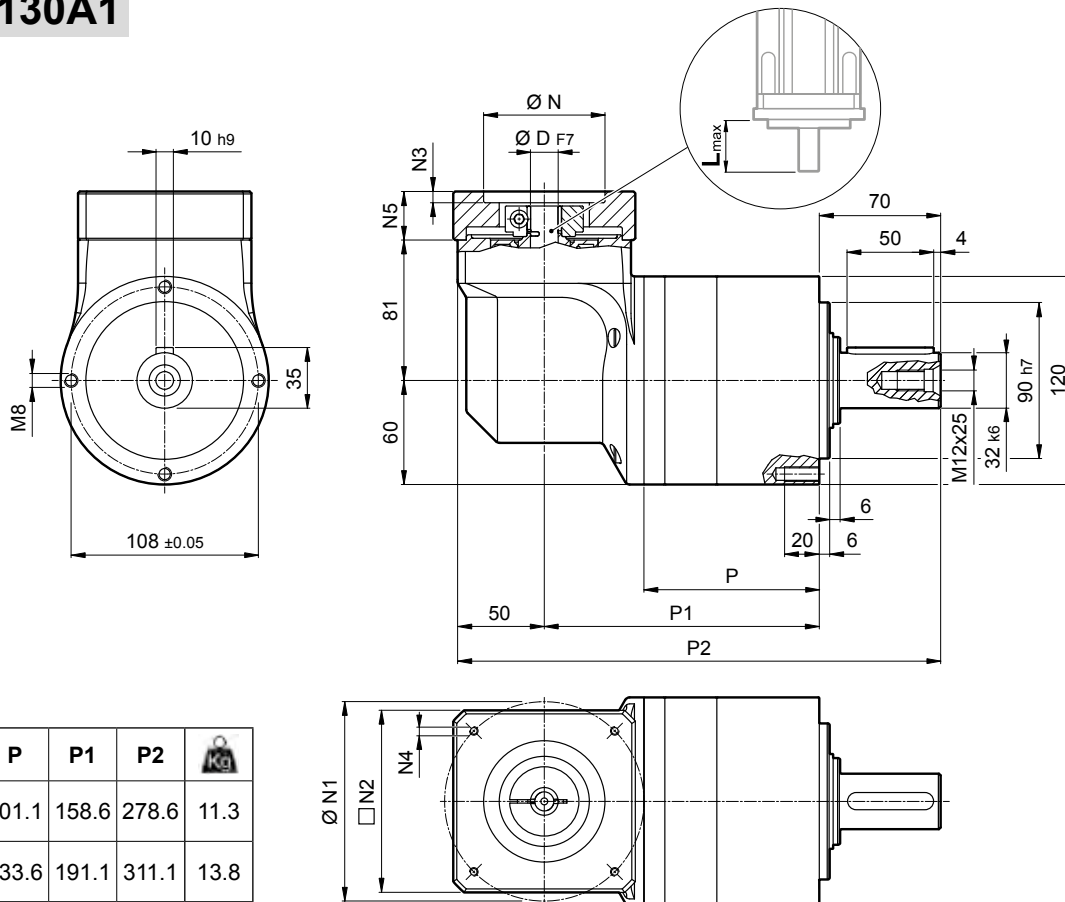

	P	P1	P2	
LCK 120 2	101.1	158.6	278.6	11.3
LCK 120 3	133.6	191.1	311.1	13.8

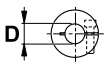
											N	N1	N2	N3	N4	N5	L _{max}
	11	12	12.7	14	15	15.875	16	19	-	-							
50D	11	12	12.7	14	15	15.875	16	19	-	-	50	95	100	5	M6x14	28	40
55A	11	12	12.7	14	15	15.875	16	19	-	-	55.5	125.7	105	5	M6x16	28	40
60A2	11	12	12.7	14	15	15.875	16	19	-	-	60	75	100	5	M5x14	28	40
60AH2	11	12	12.7	14	15	15.875	16	19	-	-	60	75	100	5	6.5	33	40
60B1	11	12	12.7	14	15	15.875	16	19	-	-	60	85	100	6.5	M5x14	28	40
70A1	11	12	12.7	14	15	15.875	16	19	-	-	70	85	100	5	M6x14	28	40
70AH1	11	12	12.7	14	15	15.875	16	19	-	-	70	85	100	5	6	33	40
70B1	11	12	12.7	14	15	15.875	16	19	-	-	70	90	100	5	M5x12	28	40
80A1	11	12	12.7	14	15	15.875	16	19	-	-	80	100	100	5	M6x16	28	40
80AH1	11	12	12.7	14	15	15.875	16	19	-	-	80	100	100	5	6.5	28	40
95A	11	12	12.7	14	15	15.875	16	19	-	-	95	115	100	5	M8x18	28	40
95A1	11	12	12.7	14	15	15.875	16	19	22	24	95	115	100	5	M8x18	38	50
95B	11	12	12.7	14	15	15.875	16	19	-	-	95	130	115	5	M8x18	28	40
110A	11	12	12.7	14	15	15.875	16	19	-	-	110	130	115	5	M8x18	28	40
110A1	11	12	12.7	14	15	15.875	16	19	22	24	110	130	115	6.5	M8x20	38	50
110B	11	12	12.7	14	15	15.875	16	19	22	24	110	145	120	6.5	M8x20	38	50
110B1	11	12	12.7	14	15	15.875	16	19	22	24	110	145	120	6.5	M8x20	48	60
130A	11	12	12.7	14	15	15.875	16	19	22	24	130	165	140	6.5	M10x20	38	50
130A1	11	12	12.7	14	15	15.875	16	19	22	24	130	165	140	6.5	M10x25	48	60

Please contact us for other motor adapters and input shaft bore.

LCK 120

FM

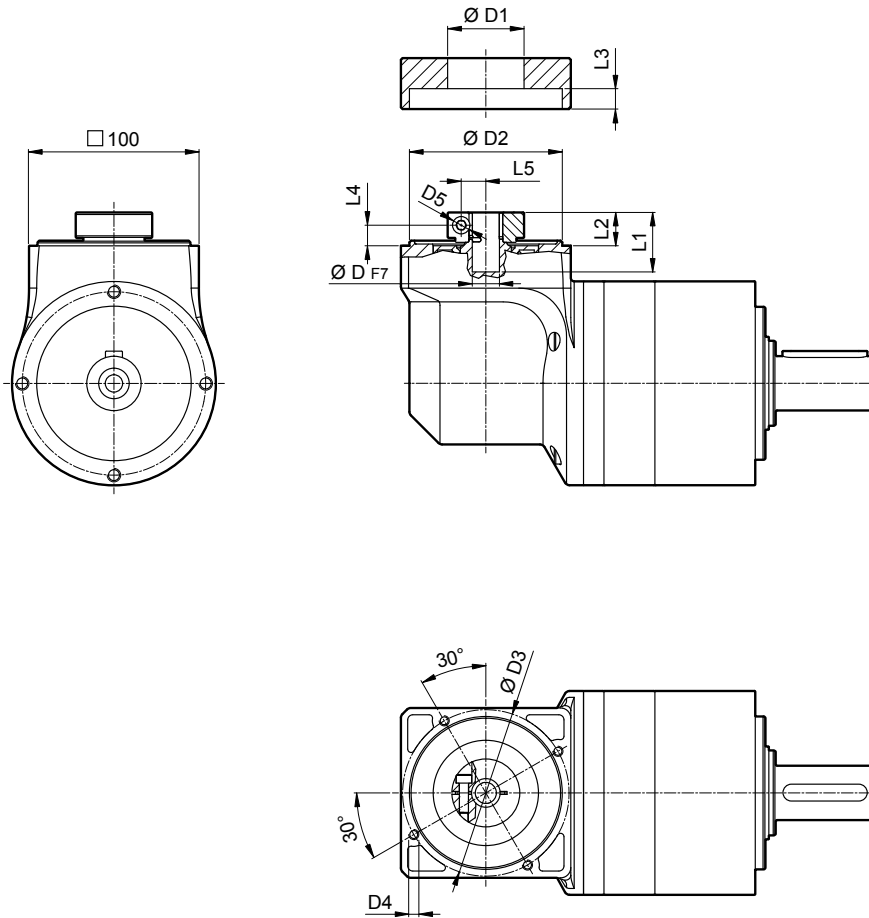



D				D1	D2	D3	D4	D5	L1	L2	L3	L4	L5
11	12	12.7		43	90	98	M6x15	M6	35	19.5	7.6	12.1	12.5
14	15	15.875	16	48	90	98	M6x15	M6	35	19.5	7.6	12.1	14.5
19				51	90	98	M6x15	M6	35	19.5	7.6	12.1	16.5
22	24			56.5	90	98	M6x15	M6	37	21.5	7.6	12.1	19

i	M _{n 2} [Nm]	M _{a 2} [Nm]	M _{p 2} [Nm]	n ₁ [min ⁻¹]	n _{1 max} [min ⁻¹]	φ _s [arcmin]	C _t [Nm / arcmin]	R _{2 max} [N]	A _{2 max} [N]	η %	J _G [kgcm ²]		
											D	11 ... 12.7	14 ... 19
LCK 120 2_6	95	160	225	2000	4500	6'	23.4	3500	3000	94	1.74	1.82	2.01
LCK 120 2_8	110	190	300	2000	4500	6'	23.4	3500	3000	94	1.52	1.60	1.79
LCK 120 2_10	110	190	360	2000	4500	6'	23.4	3500	3000	94	1.44	1.52	1.71
LCK 120 2_14	110	190	360	2000	4500	6'	23.4	3500	3000	94	1.37	1.45	1.63
LCK 120 2_20	95	160	300	2000	4500	6'	23.4	3500	3000	94	1.32	1.40	1.59
LCK 120 3_24	110	190	360	2000	4500	8'	22.9	3500	3000	91	1.64	1.72	1.90
LCK 120 3_30	110	190	360	2000	4500	8'	22.9	3500	3000	91	1.63	1.71	1.89
LCK 120 3_50	110	190	360	2000	4500	8'	22.9	3500	3000	91	1.40	1.48	1.67
LCK 120 3_70	110	190	360	2000	4500	8'	22.9	3500	3000	91	1.34	1.42	1.61
LCK 120 3_80	110	190	360	2000	4500	8'	22.9	3500	3000	91	1.31	1.39	1.58
LCK 120 3_100	110	190	360	2000	4500	8'	22.9	3500	3000	91	1.31	1.39	1.58

LCK 155

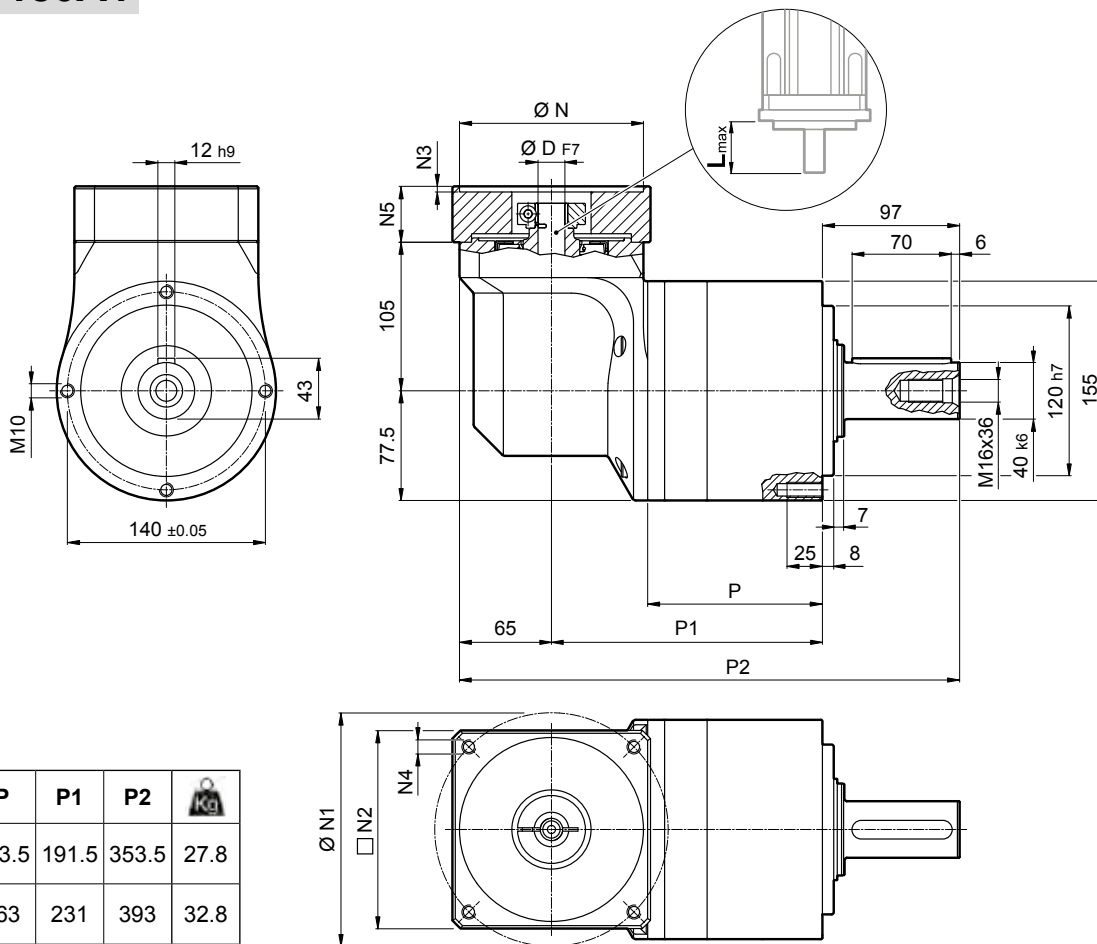
55A1 ... 180A1



	P	P1	P2	
LCK 155 2	123.5	191.5	353.5	27.8
LCK 155 3	163	231	393	32.8

LCK

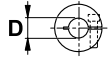
								N	N1	N2	N3	N4	N5	L _{max}
55A1	14	15.875	16	19	-	-	-	55.5	125.7	130	4	M6x15	39.5	50
80A2	14	15.875	16	19	-	-	-	80	100	130	4	M6x15	39.5	50
95A1	14	15.875	16	19	22	24	-	95	115	130	4	M8x20	39.5	50
110A1	14	15.875	16	19	22	24	-	110	130	130	4	M8x20	39.5	50
110B1	14	15.875	16	19	22	24	-	110	145	130	6.5	M8x20	49.5	60
114A	14	15.875	16	19	22	24	28	114.3	200	170	5.5	M12x25	69.5	80
130A	14	15.875	16	19	22	24	-	130	165	140	4	M10x20	39.5	50
130A1	14	15.875	16	19	22	24	28	130	165	140	4	M10x20	49.5	60
180A	14	15.875	16	19	22	24	28	180	215	190	5.5	M14x25	49.5	60
180A1	14	15.875	16	19	22	24	28	180	215	190	5.5	M14x25	69.5	80

Please contact us for other motor adapters and input shaft bore.

LCK 155

FM

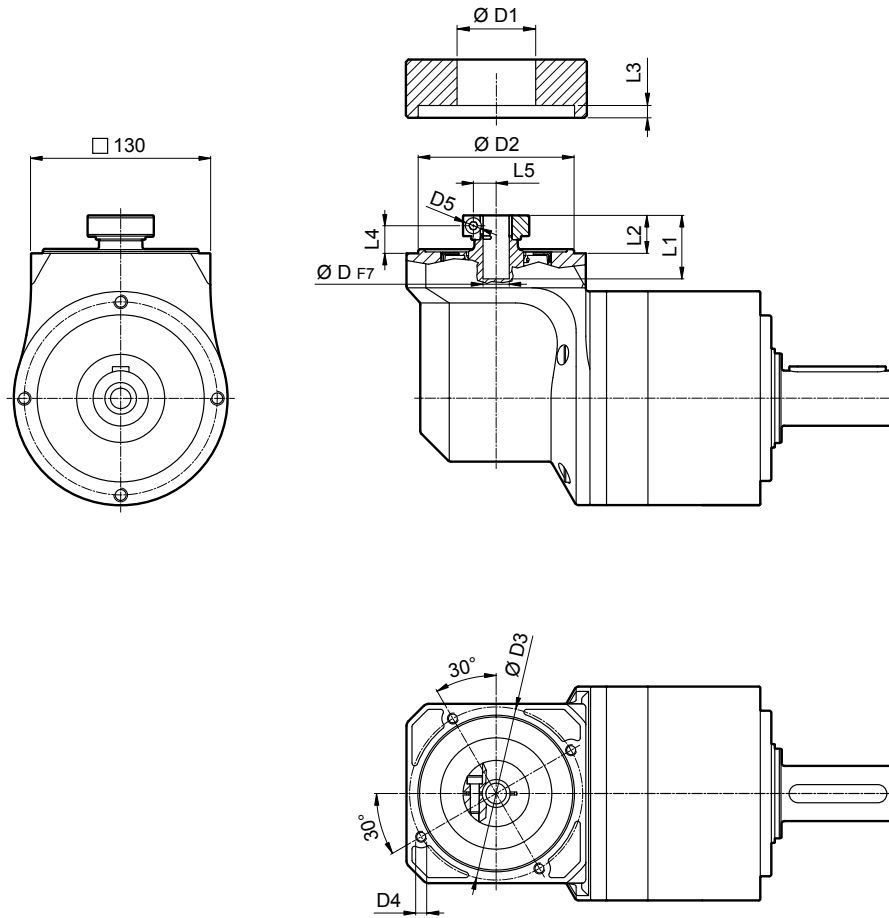

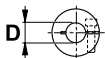
			D1	D2	D3	D4	D5	L1	L2	L3	L4	L5
14	15.875	16	48	113	125.5	M8x15	M6	46	27.5	6	20	14.5
19			51	113	125.5	M8x15	M6	46	27.5	6	20	16.5
22	24		56.5	113	125.5	M8x15	M6	47.5	29	6	20	19
28			67	113	125.5	M8x15	M8	47.5	29	6	20	22.5

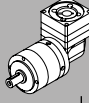
	i	M _{n 2}	M _{a 2}	M _{p 2}	n ₁	n _{1 max}	φ _s	C _t	R _{2 max}	A _{2 max}	η	J _c [kgcm ²]		
		[Nm]	[Nm]	[Nm]	[min ⁻¹]	[min ⁻¹]	[arcmin]	$\frac{Nm}{arcmin}$	[N]	[N]	%	14 ... 19	22 ; 24	28
LCK 155 2_6		250	360	510	2000	4500	6'	40.7	6000	5000	94	7.94	8.13	8.53
LCK 155 2_8		300	450	680	2000	4500	6'	40.7	6000	5000	94	7.11	7.30	7.70
LCK 155 2_10		300	450	850	2000	4500	6'	40.7	6000	5000	94	6.78	6.96	7.36
LCK 155 2_14		300	450	900	2000	4500	6'	40.7	6000	5000	94	6.48	6.67	7.07
LCK 155 2_20		230	350	750	2000	4500	6'	40.7	6000	5000	94	6.31	6.49	6.90
LCK 155 3_24		300	450	900	2000	4500	8'	37.4	6000	5000	91	7.18	7.37	7.77
LCK 155 3_30		300	450	900	2000	4500	8'	37.4	6000	5000	91	7.14	7.33	7.73
LCK 155 3_50		300	450	900	2000	4500	8'	37.4	6000	5000	91	6.49	6.68	7.08
LCK 155 3_70		300	450	900	2000	4500	8'	37.4	6000	5000	91	6.33	6.52	6.92
LCK 155 3_80		300	450	700	2000	4500	8'	37.4	6000	5000	91	6.25	6.43	6.83
LCK 155 3_100		300	450	900	2000	4500	8'	37.4	6000	5000	91	6.24	6.43	6.83

LCK

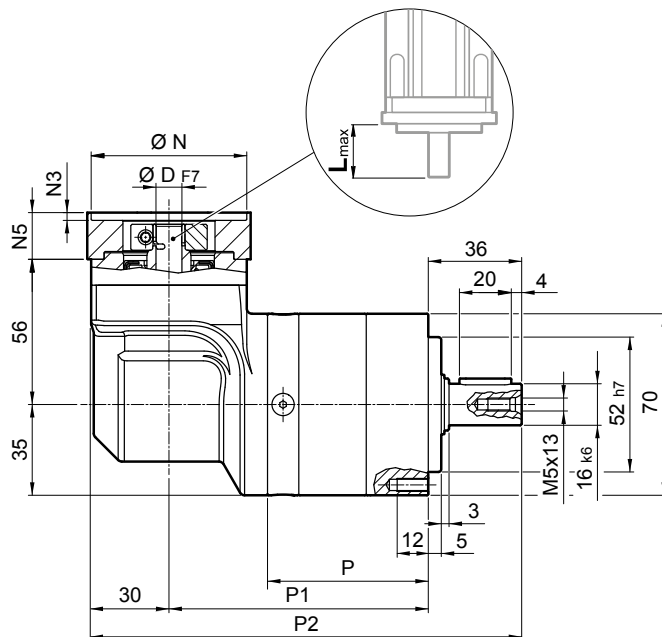
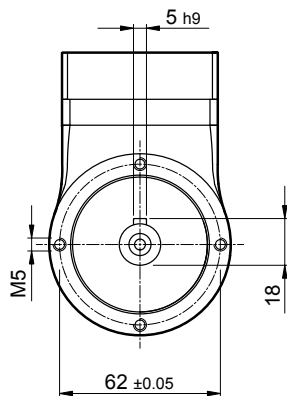

LCK 070P

25AH ... 80A

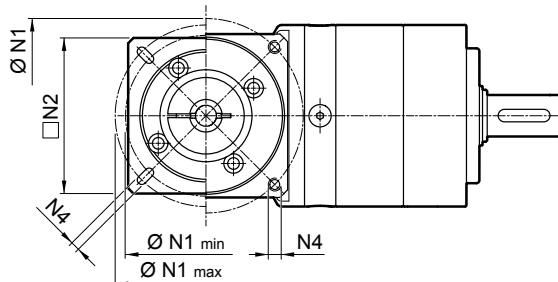

	P	P1	P2	
LCK 070P 2	62	100	166	2.7
LCK 070P 3	78.7	116.7	182.7	3.0



															N	N1		N2	N3	N4	N5	L _{max}
	D	6	6.35	7	8	9	9.52	10	11	12	12.7	14	min	max								
25AH	6	6.35	7	8	9	9.52	-	-	-	-	-	25	39	56								
26AH	6	6.35	7	8	9	9.52	-	-	-	-	-	26	39	56								
28AH	6	6.35	7	8	9	9.52	-	-	-	-	-	28	39	56								
30AH	6	6.35	7	8	9	9.52	-	-	-	-	-	30	39	56								
32AH	6	6.35	7	8	9	9.52	-	-	-	-	-	32	39	56	65	3.5	4.5	25	25			
34AH	6	6.35	7	8	9	9.52	-	-	-	-	-	34	40	56								
36AH	6	6.35	7	8	9	9.52	-	-	-	-	-	36	42	56								
39AH	6	6.35	7	8	9	9.52	-	-	-	-	-	39	45	56								
40AH	6	6.35	7	8	9	9.52	-	-	-	-	-	40	46	56								
38B	6	6.35	7	8	9	9.52	10	11	12	12.7	-	38.1	66.6	60	3	M4x10	18	25				
40B	6	6.35	7	8	9	9.52	10	11	12	12.7	-	40	63	60	3	M4x10	18	25				
50A	6	6.35	7	8	9	9.52	10	11	12	12.7	-	50	60	60	3	M4x10	18	25				
50B	6	6.35	7	8	9	9.52	10	11	12	12.7	14	50	65	60	3	M5x12	23	30				
50BH	6	6.35	7	8	9	9.52	10	11	12	12.7	14	50	65	65	3	5.5	25	32				
50C	6	6.35	7	8	9	9.52	10	11	12	12.7	14	50	70	60	3	M4x10	23	30				
55MH	6	6.35	7	8	9	9.52	10	11	12	12.7	-	55	80	65	2	5.5	16	23				
60A	6	6.35	7	8	9	9.52	10	11	12	12.7	-	60	75	63	3	M5x12	18	25				
60A1	6	6.35	7	8	9	9.52	10	11	12	12.7	14	60	75	63	3	M5x12	23	30				
60B	6	6.35	7	8	9	9.52	10	11	12	12.7	14	60	85	75	3	M5x12	23	30				
60C	6	6.35	7	8	9	9.52	10	11	12	12.7	14	60	90	75	3	M5x12	23	30				
70A	6	6.35	7	8	9	9.52	10	11	12	12.7	14	70	85	75	3	M6x15	23	30				
70B	6	6.35	7	8	9	9.52	10	11	12	12.7	14	70	90	75	3	M5x12	23	30				
73A	6	6.35	7	8	9	9.52	10	11	12	12.7	14	73	98.4	85	3	M5x12	25	32				
80A	6	6.35	7	8	9	9.52	10	11	12	12.7	14	80	100	85	3	M6x15	23	30				

Please contact us for other motor adapters and input shaft bore.

LCK

LCK 070P

FM

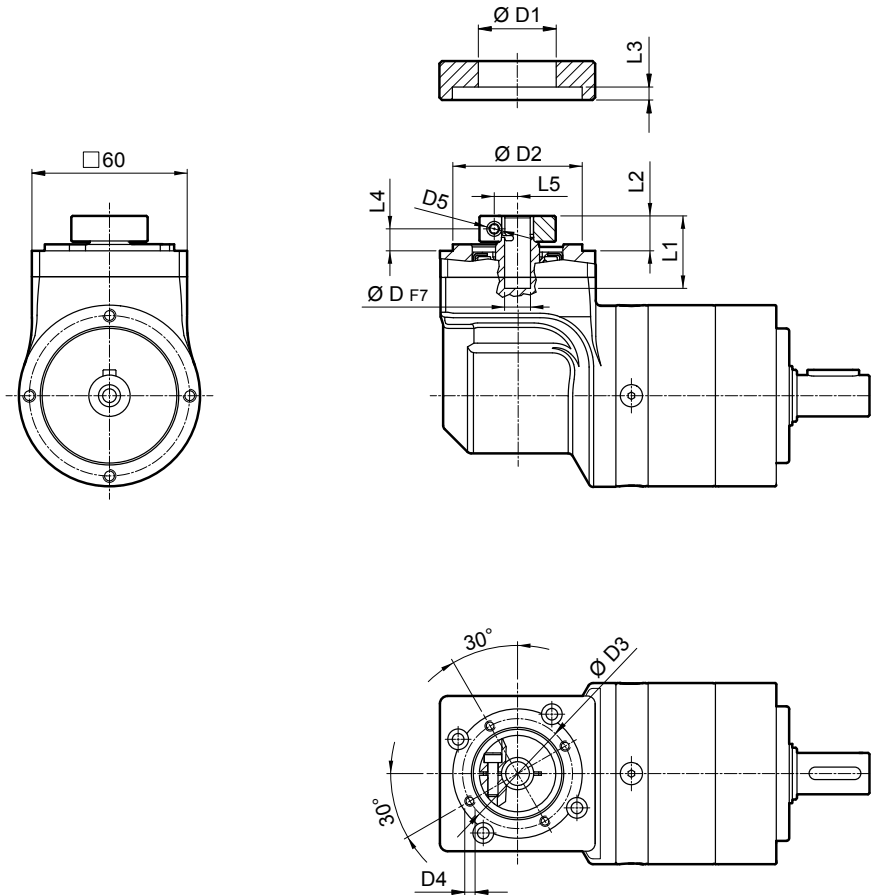

				D1	D2	D3	D4	D5	L1	L2	L3	L4	L5
6	6.35	7		32.5	50	42.5	M4x8	M4	28	13.5	3	8.5	8
8	9	9.52	10	32.5	50	42.5	M4x8	M4	28	13.5	3	8.5	9
11	12	12.7		35.5	50	42.5	M4x8	M4	23	13.5	3	8.5	11
14				35.5	50	42.5	M4x8	M4	25	15.5	3	8.9	11.5

	i	M _{n 2}	M _{a 2}	M _{p 2}	n ₁	n _{1 max}	φ _s	C _t	R _{2 max}	A _{2 max}	η	J _G [kgcm ²]	
		[Nm]	[Nm]	[Nm]	[min ⁻¹]	[min ⁻¹]	[arcmin]	$\frac{Nm}{arcmin}$	[N]	[N]	%		6 ... 9.52
LCK 070P 2_6		25	38	45	2500	5000	6'	2.8	1300	1400	94	0.25	0.26
LCK 070P 2_8		30	40	60	2500	5000	6'	2.8	1300	1400	94	0.24	0.25
LCK 070P 2_10		25	40	70	2500	5000	6'	2.8	1300	1400	94	0.23	0.25
LCK 070P 2_14		25	40	70	2500	5000	6'	2.8	1300	1400	94	0.23	0.24
LCK 070P 2_20		18	30	60	2500	5000	6'	2.8	1300	1400	94	0.23	0.24
LCK 070P 3_24		29	45	70	2500	5000	8'	2.5	1300	1400	91	0.24	0.26
LCK 070P 3_30		29	45	70	2500	5000	8'	2.5	1300	1400	91	0.24	0.26
LCK 070P 3_50		30	45	70	2500	5000	8'	2.5	1300	1400	91	0.23	0.24
LCK 070P 3_70		30	45	70	2500	5000	8'	2.5	1300	1400	91	0.23	0.24
LCK 070P 3_80		30	45	70	2500	5000	8'	2.5	1300	1400	91	0.23	0.24
LCK 070P 3_100		30	45	70	2500	5000	8'	2.5	1300	1400	91	0.23	0.24

LCK

LCK 090P

40B1 ... 110B1

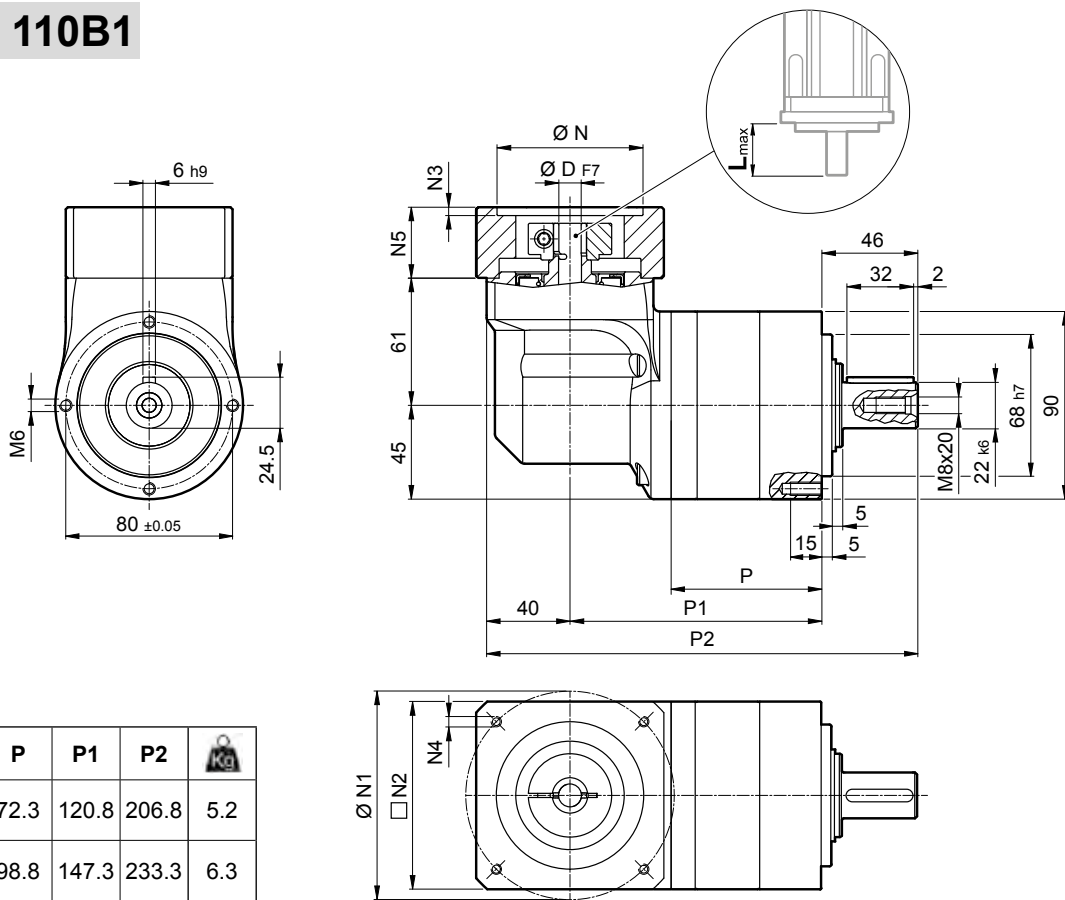

	P	P1	P2	
LCK 090P 2	72.3	120.8	206.8	5.2
LCK 090P 3	98.8	147.3	233.3	6.3

LCK

											N	N1	N2	N3	N4	N5	Lmax		
40B1	8	9	9.52	11	12	12.7	14	-	-	-	-	40	63	80	4	M4x10	34	40	
45A	8	9	9.52	11	12	12.7	-	-	-	-	-	45	63	80	4	M4x10	34	40	
50B1	8	9	9.52	11	12	12.7	14	-	-	-	-	50	65	80	4	M5x16	34	40	
50BH1	8	9	9.52	11	12	12.7	14	-	-	-	-	50	65	80	4	5.5	34	40	
50C1	8	9	9.52	11	12	12.7	14	-	-	-	-	50	70	80	4	M4x10	34	40	
50D	8	9	9.52	11	12	12.7	14	-	-	-	-	50	95	80	4	M6x10	34	40	
55A	8	9	9.52	11	12	12.7	14	15.875	16	17	19	19.05	55.5	125.7	105	4	M6x16	34	40
60A2	8	9	9.52	11	12	12.7	14	-	-	-	-	60	75	80	4	M5x16	34	40	
60AH2	8	9	9.52	11	12	12.7	14	-	-	-	-	60	75	90	4	5.5	34	40	
60B1	8	9	9.52	11	12	12.7	14	15.875	16	-	-	60	85	80	4	M5x16	34	40	
60C1	8	9	9.52	11	12	12.7	14	15.875	16	-	-	60	90	80	4	M5x16	34	40	
70A1	8	9	9.52	11	12	12.7	14	15.875	16	17	19	19.05	70	85	80	4	M6x20	34	40
70AH1	8	9	9.52	11	12	12.7	14	15.875	16	17	19	19.05	70	85	90	4	6.5	34	40
70B1	8	9	9.52	11	12	12.7	14	15.875	16	17	19	19.05	70	90	80	4	M5x16	34	40
73A1	8	9	9.52	11	12	12.7	14	-	-	-	-	73	98.4	85	4	M5x16	34	40	
80A1	8	9	9.52	11	12	12.7	14	15.875	16	17	19	19.05	80	100	90	4	M6x16	34	40
95A	8	9	9.52	11	12	12.7	14	15.875	16	17	19	19.05	95	115	100	4	M8x20	34	40
95B	8	9	9.52	11	12	12.7	14	15.875	16	17	19	19.05	95	130	115	4	M8x20	34	40
110A	8	9	9.52	11	12	12.7	14	15.875	16	17	19	19.05	110	130	115	4	M8x20	34	40
110B	8	9	9.52	11	12	12.7	14	15.875	16	17	19	19.05	110	145	120	6.5	M8x20	44	50
110B1	8	9	9.52	11	12	12.7	14	15.875	16	17	19	19.05	110	145	120	6.5	M8x20	54	60

Please contact us for other motor adapters and input shaft bore.

LCK 090P

FM

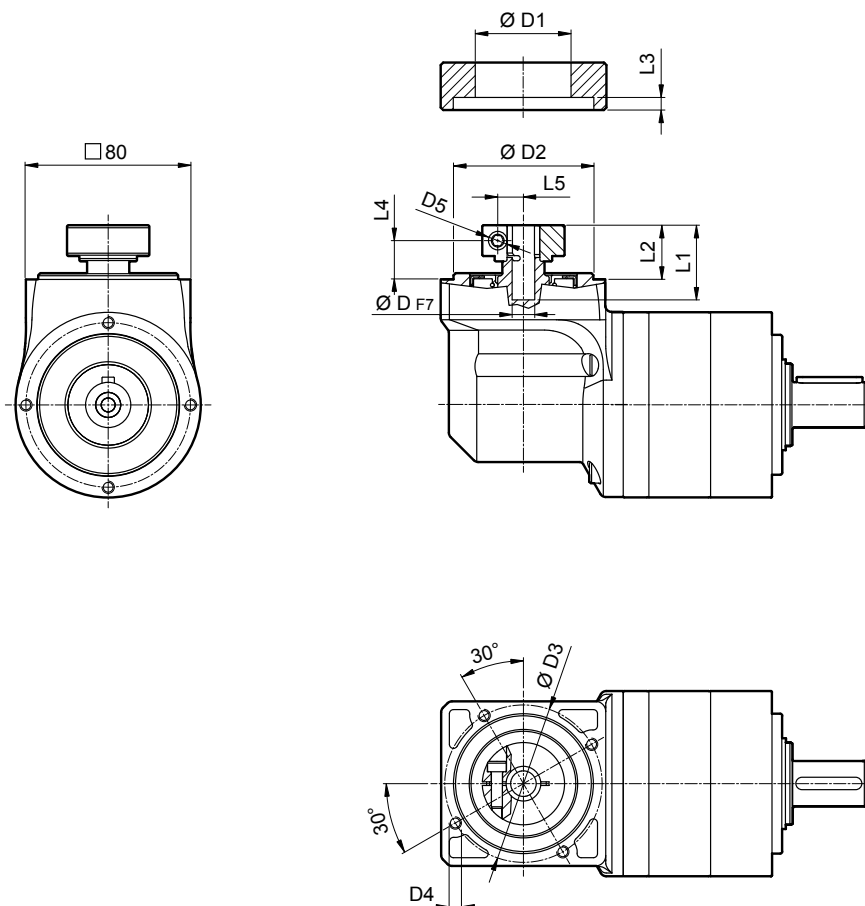

				D1	D2	D3	D4	D5	L1	L2	L3	L4	L5
8	9	9.52		38	68	76.5	M6x10	M6	36.3	26.3	9.5	18.8	10.5
11	12	12.7		43	68	76.5	M6x10	M6	36.3	26.3	9.5	18.8	12.5
14	15.875	16	17	48	68	76.5	M6x10	M6	36.3	26.3	9.5	18.8	14.5
19	19.05			51	68	76.5	M6x10	M6	36.3	26.3	9.5	18.8	16.5

	i	M _{n2}	M _{a2}	M _{p2}	n ₁	n _{1 max}	φ _s	C _t	R _{2 max}	A _{2 max}	η	J _G [kgcm ²]	
		[Nm]	[Nm]	[Nm]	[min ⁻¹]	[min ⁻¹]	[arcmin]	$\frac{Nm}{arcmin}$	[N]	[N]	%	8 ... 12.7	14 ... 19
LCK 090P 2_6		45	70	90	2500	5000	6'	11	2200	1900	94	0.85	1.03
LCK 090P 2_8		60	90	120	2500	5000	6'	11	2200	1900	94	0.79	0.98
LCK 090P 2_10		50	90	150	2500	5000	6'	8	2200	1900	94	0.77	0.96
LCK 090P 2_14		50	90	160	2500	5000	6'	8	2200	1900	94	0.75	0.94
LCK 090P 2_20		40	70	150	2500	5000	6'	8	2200	1900	94	0.74	0.93
LCK 090P 3_24		60	90	160	2500	5000	8'	10.8	2200	1900	91	0.81	1.00
LCK 090P 3_30		60	90	160	2500	5000	8'	10.8	2200	1900	91	0.81	1.00
LCK 090P 3_50		50	90	160	2500	5000	8'	7.8	2200	1900	91	0.76	0.94
LCK 090P 3_70		50	90	160	2500	5000	8'	7.8	2200	1900	91	0.74	0.93
LCK 090P 3_80		60	90	160	2500	5000	8'	10.8	2200	1900	91	0.74	0.93
LCK 090P 3_100		50	90	160	2500	5000	8'	7.8	2200	1900	91	0.74	0.93

LCK

LCK 120P

50D ... 130A1

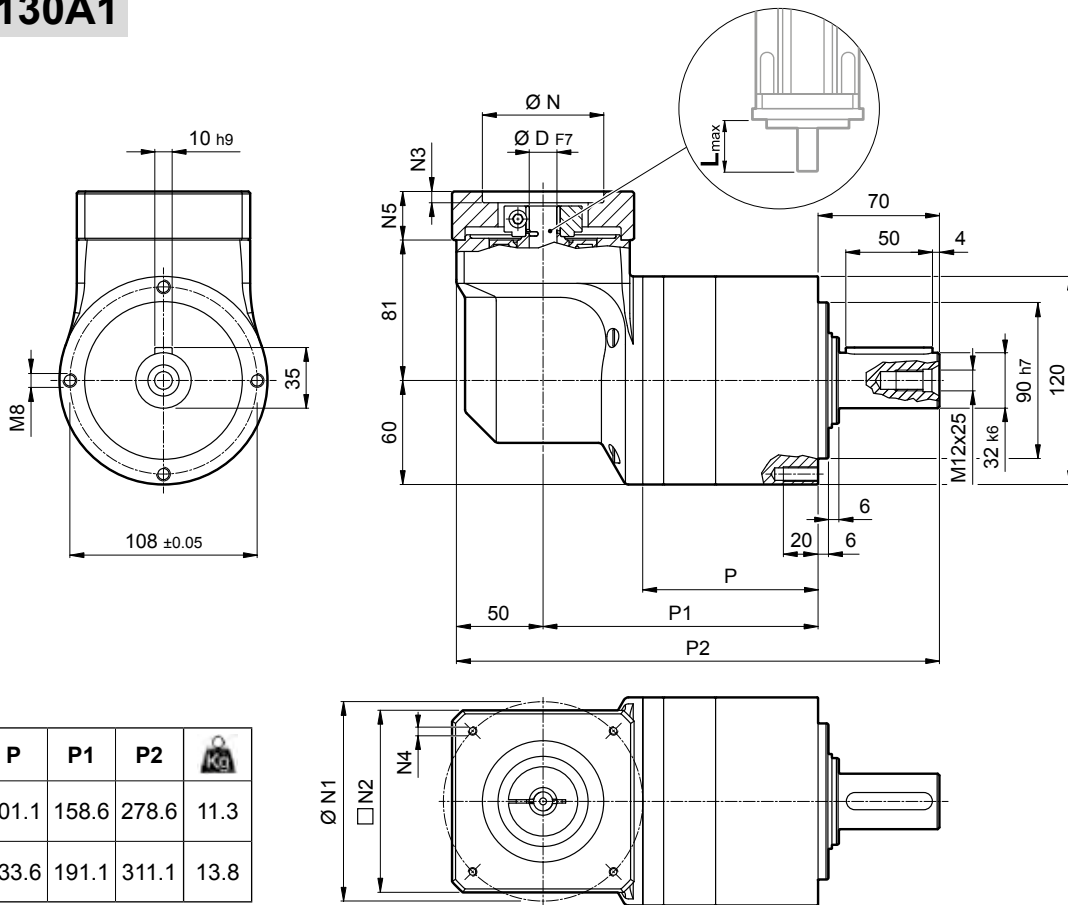

	P	P1	P2	
LCK 120P 2	101.1	158.6	278.6	11.3
LCK 120P 3	133.6	191.1	311.1	13.8

LCK

											N	N1	N2	N3	N4	N5	L _{max}
	D	11	12	12.7	14	15	15.875	16	19	—							
50D	11	12	12.7	14	15	15.875	16	19	—	—	50	95	100	5	M6x14	28	40
55A	11	12	12.7	14	15	15.875	16	19	—	—	55.5	125.7	105	5	M6x16	28	40
60A2	11	12	12.7	14	15	15.875	16	19	—	—	60	75	100	5	M5x14	28	40
60AH2	11	12	12.7	14	15	15.875	16	19	—	—	60	75	100	5	6.5	33	40
60B1	11	12	12.7	14	15	15.875	16	19	—	—	60	85	100	6.5	M5x14	28	40
70A1	11	12	12.7	14	15	15.875	16	19	—	—	70	85	100	5	M6x14	28	40
70AH1	11	12	12.7	14	15	15.875	16	19	—	—	70	85	100	5	6	33	40
70B1	11	12	12.7	14	15	15.875	16	19	—	—	70	90	100	5	M5x12	28	40
80A1	11	12	12.7	14	15	15.875	16	19	—	—	80	100	100	5	M6x16	28	40
80AH1	11	12	12.7	14	15	15.875	16	19	—	—	80	100	100	5	6.5	28	40
95A	11	12	12.7	14	15	15.875	16	19	—	—	95	115	100	5	M8x18	28	40
95A1	11	12	12.7	14	15	15.875	16	19	22	24	95	115	100	5	M8x18	38	50
95B	11	12	12.7	14	15	15.875	16	19	—	—	95	130	115	5	M8x18	28	40
110A	11	12	12.7	14	15	15.875	16	19	—	—	110	130	115	5	M8x18	28	40
110A1	11	12	12.7	14	15	15.875	16	19	22	24	110	130	115	6.5	M8x20	38	50
110B	11	12	12.7	14	15	15.875	16	19	22	24	110	145	120	6.5	M8x20	38	50
110B1	11	12	12.7	14	15	15.875	16	19	22	24	110	145	120	6.5	M8x20	48	60
130A	11	12	12.7	14	15	15.875	16	19	22	24	130	165	140	6.5	M10x20	38	50
130A1	11	12	12.7	14	15	15.875	16	19	22	24	130	165	140	6.5	M10x25	48	60

Please contact us for other motor adapters and input shaft bore.

LCK 120P

FM

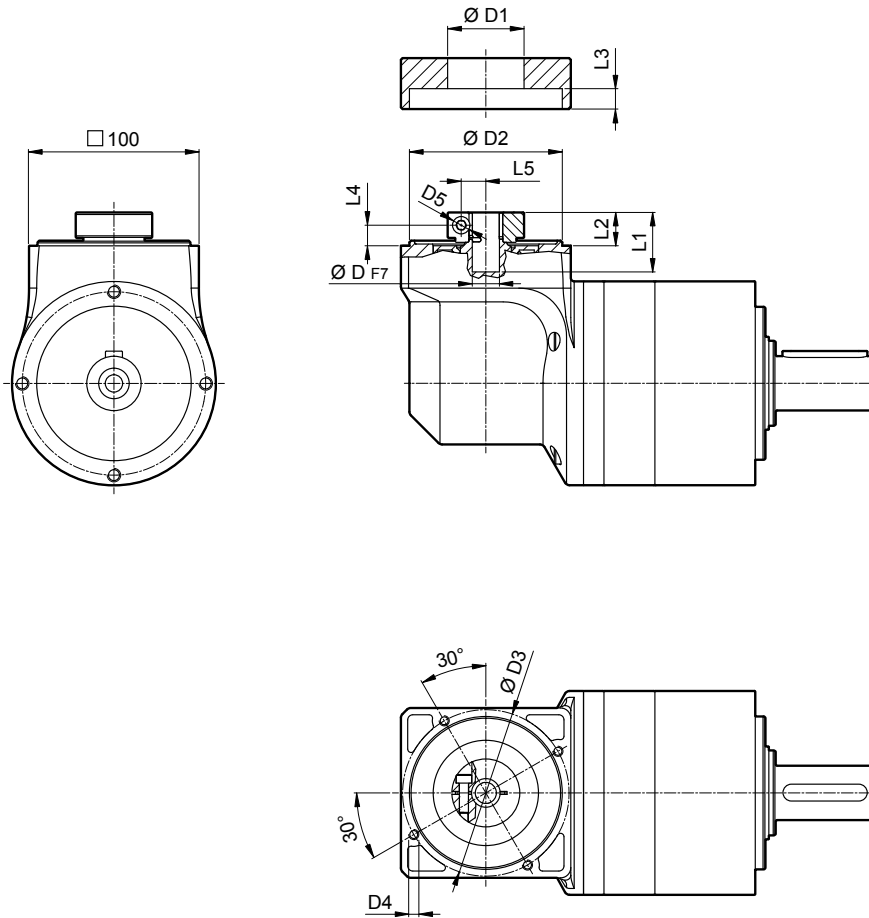

				D1	D2	D3	D4	D5	L1	L2	L3	L4	L5
11	12	12.7		43	90	98	M6x15	M6	35	19.5	7.6	12.1	12.5
14	15	15.875	16	48	90	98	M6x15	M6	35	19.5	7.6	12.1	14.5
19				51	90	98	M6x15	M6	35	19.5	7.6	12.1	16.5
22	24			56.5	90	98	M6x15	M6	37	21.5	7.6	12.1	19

	i	M _{n2}	M _{a2}	M _{p2}	n ₁	n _{1 max}	φ _s	C _t	R _{2 max}	A _{2 max}	η	J _G [kgcm ²]		
		[Nm]	[Nm]	[Nm]	[min ⁻¹]	[min ⁻¹]	[arcmin]	$\frac{Nm}{arcmin}$	[N]	[N]	%	14 ... 19	22 ; 24	28 ; 32
LCK 120P 2_6		110	160	225	2000	4500	6'	28.4	3500	3000	94	1.74	1.82	2.01
LCK 120P 2_8		140	220	300	2000	4500	6'	28.4	3500	3000	94	1.52	1.60	1.79
LCK 120P 2_10		125	220	360	2000	4500	6'	28.4	3500	3000	94	1.44	1.52	1.71
LCK 120P 2_14		125	220	360	2000	4500	6'	28.4	3500	3000	94	1.37	1.45	1.63
LCK 120P 2_20		100	160	300	2000	4500	6'	28.4	3500	3000	94	1.32	1.40	1.59
LCK 120P 3_24		155	220	360	2000	4500	8'	28.4	3500	3000	91	1.64	1.72	1.90
LCK 120P 3_30		155	220	360	2000	4500	8'	28.4	3500	3000	91	1.63	1.71	1.89
LCK 120P 3_50		125	220	360	2000	4500	8'	22.9	3500	3000	91	1.40	1.48	1.67
LCK 120P 3_70		125	220	360	2000	4500	8'	22.9	3500	3000	91	1.34	1.42	1.61
LCK 120P 3_80		155	220	360	2000	4500	8'	28.4	3500	3000	91	1.31	1.39	1.58
LCK 120P 3_100		125	220	360	2000	4500	8'	22.9	3500	3000	91	1.31	1.39	1.58

LCK

LCK 155P

55A1 ... 180A1

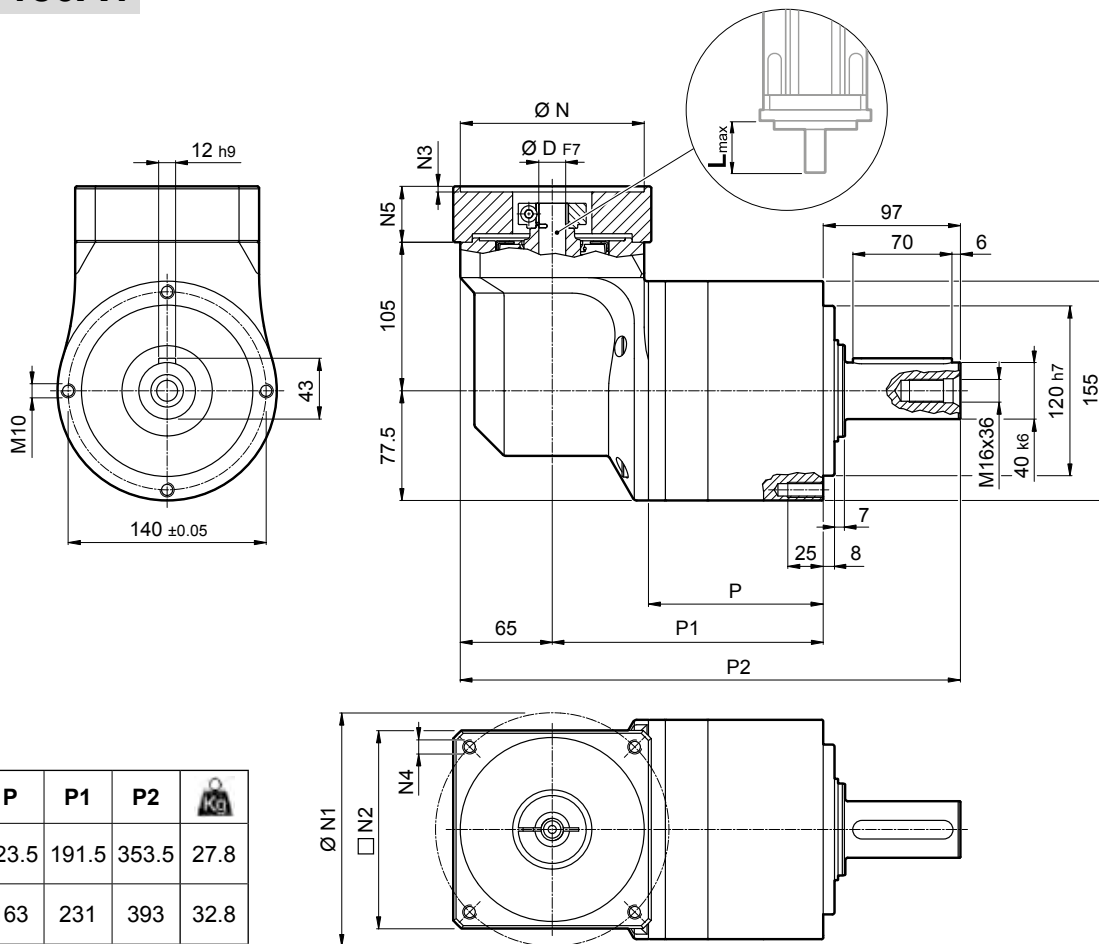

	P	P1	P2	
LCK 155P 2	123.5	191.5	353.5	27.8
LCK 155P 3	163	231	393	32.8

LCK

								N	N1	N2	N3	N4	N5	L _{max}
55A1	14	15.875	16	19	-	-	-	55.5	125.7	130	4	M6x15	39.5	50
80A2	14	15.875	16	19	-	-	-	80	100	130	4	M6x15	39.5	50
95A1	14	15.875	16	19	22	24	-	95	115	130	4	M8x20	39.5	50
110A1	14	15.875	16	19	22	24	-	110	130	130	4	M8x20	39.5	50
110B1	14	15.875	16	19	22	24	-	110	145	130	6.5	M8x20	49.5	60
114A	14	15.875	16	19	22	24	28	114.3	200	170	5.5	M12x25	69.5	80
130A	14	15.875	16	19	22	24	-	130	165	140	4	M10x20	39.5	50
130A1	14	15.875	16	19	22	24	28	130	165	140	4	M10x20	49.5	60
180A	14	15.875	16	19	22	24	28	180	215	190	5.5	M14x25	49.5	60
180A1	14	15.875	16	19	22	24	28	180	215	190	5.5	M14x25	69.5	80

Please contact us for other motor adapters and input shaft bore.

LCK 155P

FM

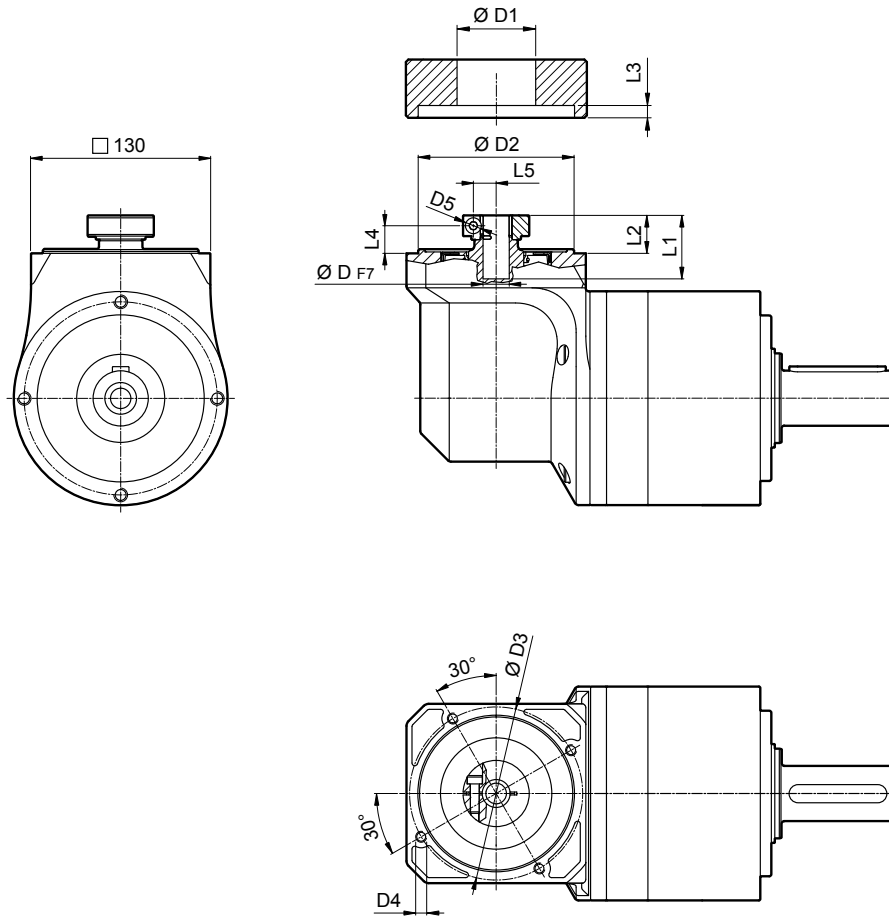

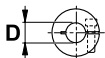
			D1	D2	D3	D4	D5	L1	L2	L3	L4	L5
14	15.875	16	48	113	125.5	M8x15	M6	46	27.5	6	20	14.5
19			51	113	125.5	M8x15	M6	46	27.5	6	20	16.5
22	24		56.5	113	125.5	M8x15	M6	47.5	29	6	20	19
28			67	113	125.5	M8x15	M8	47.5	29	6	20	22.5

	i	M _{n2} [Nm]	M _{a2} [Nm]	M _{p2} [Nm]	n ₁ [min ⁻¹]	n _{1 max} [min ⁻¹]	φ _s [arcmin]	C _t [$\frac{Nm}{arcmin}$]	R _{2 max} [N]	A _{2 max} [N]	η %	J _G [kgcm ²]		
												14 ... 19	22 ; 24	28
LCK 155P 2_6		250	380	600	2000	4500	6'	47.9	6000	5000	94	7.94	8.13	8.53
LCK 155P 2_8		350	500	1000	2000	4500	6'	47.9	6000	5000	94	7.11	7.30	7.70
LCK 155P 2_10		350	500	1000	2000	4500	6'	47.9	6000	5000	94	6.78	6.96	7.36
LCK 155P 2_14		350	500	1000	2000	4500	6'	47.9	6000	5000	94	6.48	6.67	7.07
LCK 155P 2_20		230	350	750	2000	4500	6'	47.9	6000	5000	94	6.31	6.49	6.90
LCK 155P 3_24		450	700	1000	2000	4500	8'	44.6	6000	5000	91	7.18	7.37	7.77
LCK 155P 3_30		450	700	1000	2000	4500	8'	44.6	6000	5000	91	7.14	7.33	7.73
LCK 155P 3_50		450	700	1000	2000	4500	8'	44.6	6000	5000	91	6.49	6.68	7.08
LCK 155P 3_70		450	700	1000	2000	4500	8'	44.6	6000	5000	91	6.33	6.52	6.92
LCK 155P 3_80		450	700	1000	2000	4500	8'	44.6	6000	5000	91	6.25	6.43	6.83
LCK 155P 3_100		450	700	1000	2000	4500	8'	44.6	6000	5000	91	6.24	6.43	6.83

LCK

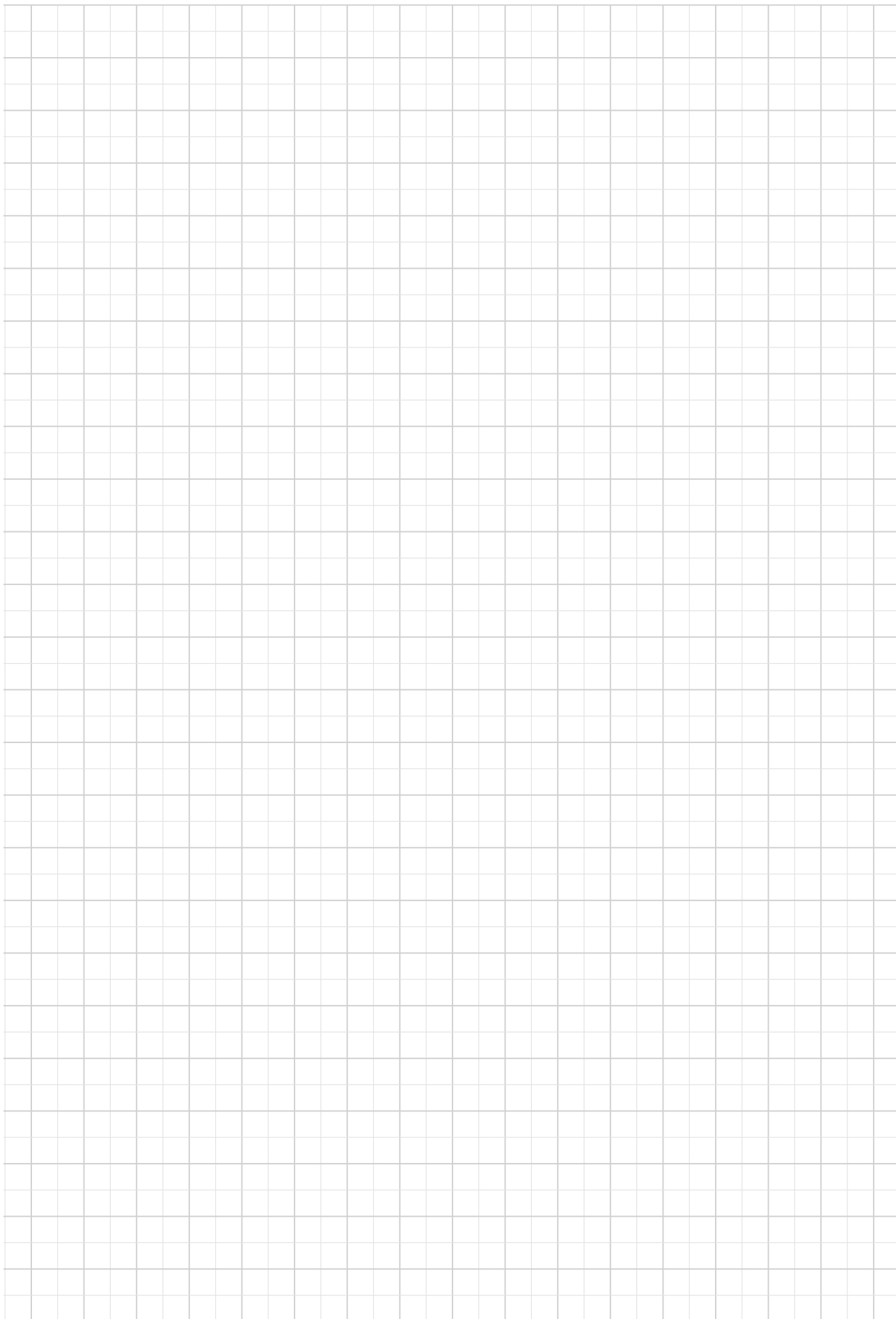

LCK

SL PLANETARY PRECISION GEARBOX FOR PULLEY DRIVES

SL - Planetary precision gearbox for pulley drives Series knows no rivals in compactness, efficiency and optimization for timing belt pulley drive systems.

This series is the ideal complement to conveyor belt servo-drives and all other applications needing to combine high precision with ultra-compact size.

Improved Performance as the key to downsizing

Enhanced performance of our SL precision gearbox (New "P" option) may open up important downsizing in many applications where previously was impossible to ensure a higher transmissible output torque.

As an additional benefit, downsizing lead to an improvement of energy efficiency by selecting a more compact gearbox with higher torque density and reducing significantly the acceleration mass.

Transmissible torque is now improved up to 40%.



Product Line Up:

- High Torque Density Option "P" available to extend Product Performance
- Higher Acceleration and Nominal Torques
- Higher Radial and Axial Load Capacities
- Designed for Cyclic and Continuous Duty
- Higher Torsional Stiffness
- Geometrical Backlash less than 6 arcmin
- Optionally available with a Timing Belt Pulley.
- Quiet Running
- Universal Design allow any Mounting Orientation

9 FEATURES OF SL SERIES

The SL Series from Tecnoingranaggi knows no rivals in compactness, efficiency and optimisation for timing belt pulley drive systems. Reduced backlash units from the SL Series are the ideal complement to conveyor belt servo-drives and all other applications needing to combine high precision with ultra-compact size.

- Available with either standard (STD) or reduced (LOW) backlash:
1-stage units: standard $\varphi_S \leq 12'$; reduced $\varphi_R \leq 6'$
2-stage units: standard $\varphi_S \leq 15'$; reduced $\varphi_R \leq 8'$
- A high IP rating (IP64) provides inner parts with protection against the ingress of dust and liquids.
- Input section oil seals made from a Fluoroelastomer compound are supplied as standard.
- Noise pressure level $L_p \leq 70$ dB(A). Conditions: distance 1 m; measured without load an input speed of $n_1 = 3000$ min⁻¹; $i=10$.
- Units are factory packed with synthetic grease to NLGI consistency class 00, in the absence of contamination the lubricant requires no periodical changes.
- Ambient temperature min -20°C, max +30°C. For temperature higher than 30°C please consider derating factor f_T .
- Housing temperature must not exceed $T_{max} = 90^\circ\text{C}$.
- Available as Version P with higher output Torque.

		Distribution of nominal torque M_{n2} [Nm]																
[i]	3	4	5	7	9	10	12	15	16	20	25	28	30	35	40	50	70	100
SL 070	18	25	25	25	18	18	25	25	25	25	25	25	18	25	25	25	25	18
SL 070P	29	30	25	25	29	18	29	29	30	30	30	30	29	30	30	30	30	18
SL 090	37	43	43	43	37	37	43	43	43	43	43	43	37	43	43	43	43	37
SL 090P	65	60	50	50	65	40	65	65	60	60	50	50	65	50	60	50	50	40
SL 120	95	110	110	110	95	95	110	110	110	110	110	110	95	110	110	110	110	95
SL 120P	155	155	125	125	155	100	155	155	155	155	125	125	155	125	155	125	125	100

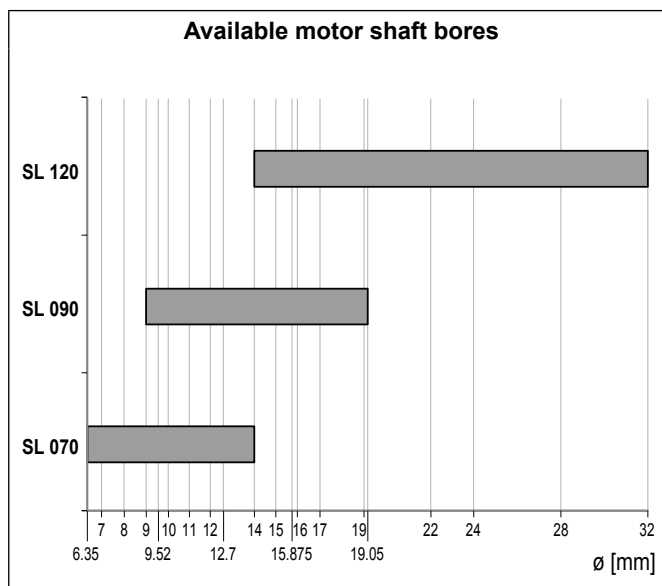
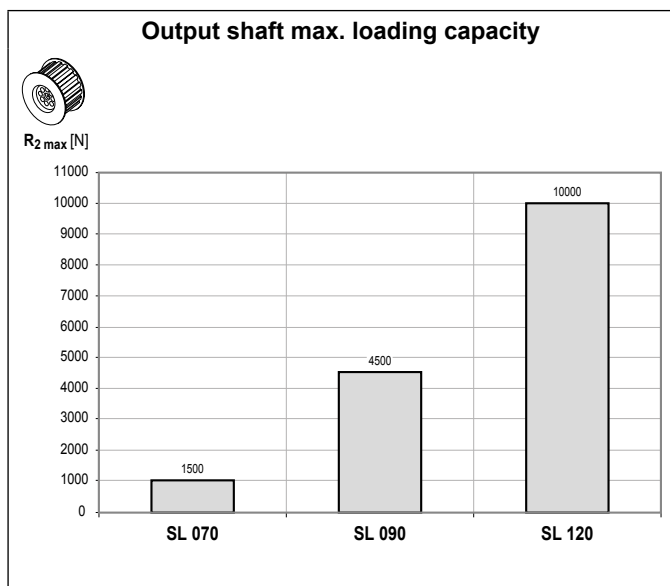

SL

9.1 ORDERING CODE

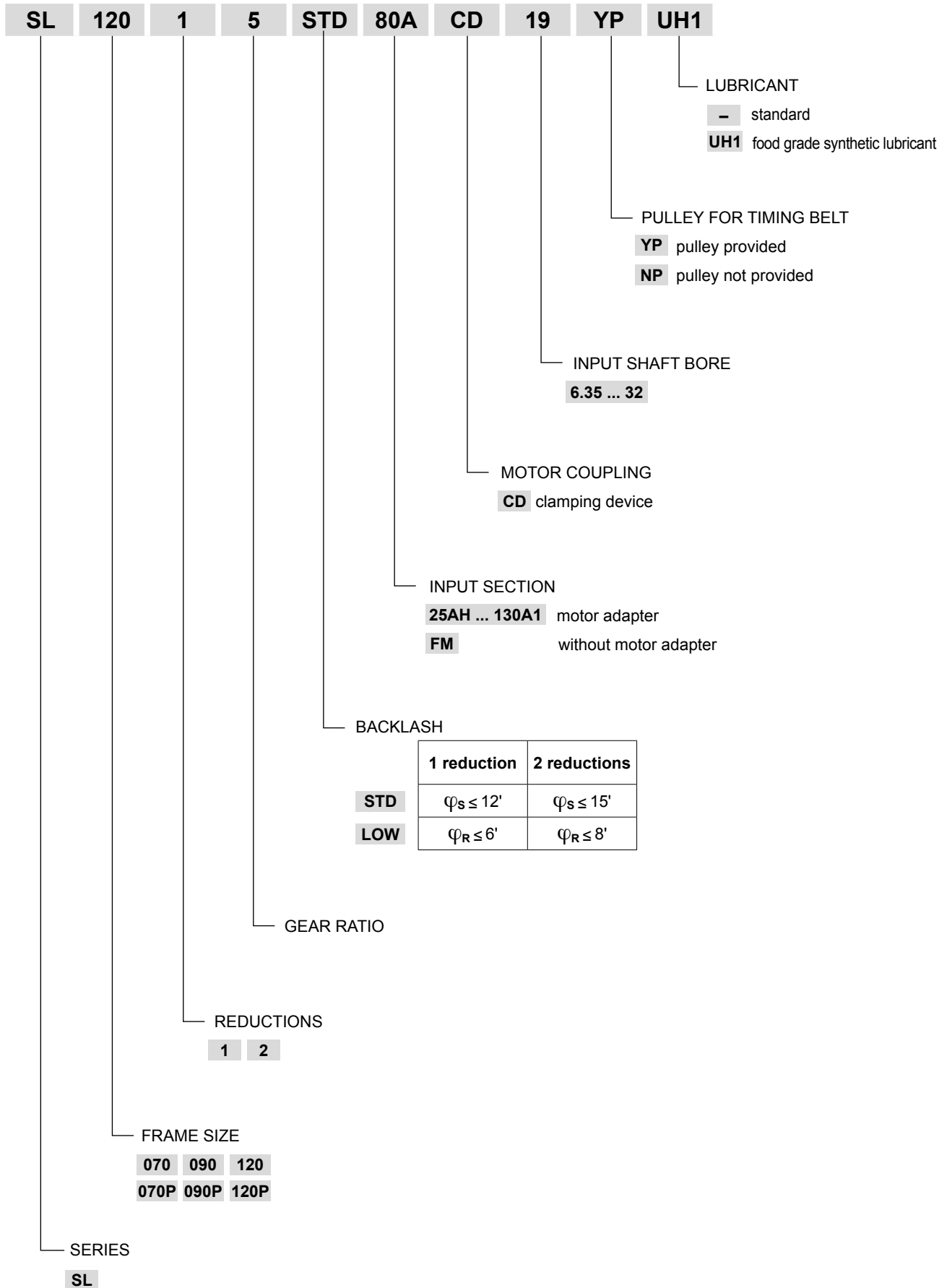

S-M-BOR-NL-CAFS-001-V01

SL

9.2 DIMENSIONS AND TECHNICAL SPECIFICATIONS

SL 070

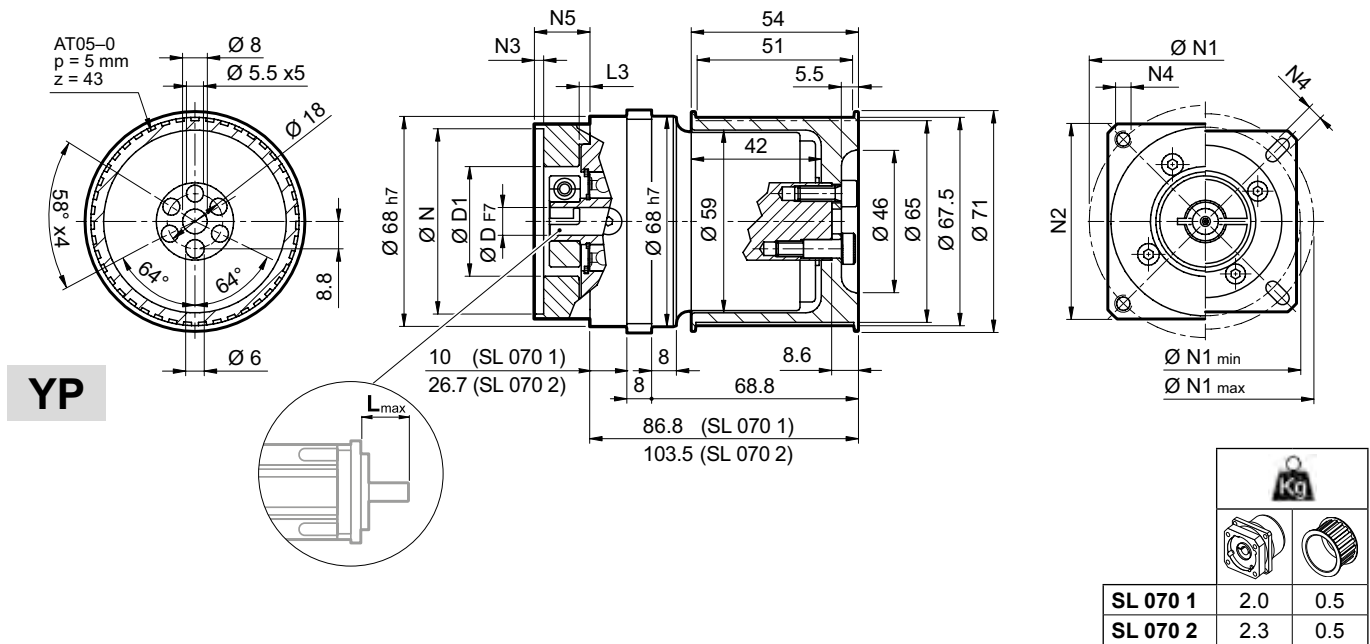

	D										N	N1		N2	N3	N4	N5	L _{max}
												min	max					
25AH	6.35	7	8	9	9.52	-	-	-	-	-	25	39	56					
26AH	6.35	7	8	9	9.52	-	-	-	-	-	26	39	56					
28AH	6.35	7	8	9	9.52	-	-	-	-	-	28	39	56					
30AH	6.35	7	8	9	9.52	-	-	-	-	-	30	39	56					
32AH	6.35	7	8	9	9.52	-	-	-	-	-	32	39	56	65	3.5	4.5	25	25
34AH	6.35	7	8	9	9.52	-	-	-	-	-	34	40	56					
36AH	6.35	7	8	9	9.52	-	-	-	-	-	36	42	56					
39AH	6.35	7	8	9	9.52	-	-	-	-	-	39	45	56					
40AH	6.35	7	8	9	9.52	-	-	-	-	-	40	46	56					
38B	6.35	7	8	9	9.52	10	11	12	12.7	-	38.1	66.6	60	3	M4x10	18	25	
40B	6.35	7	8	9	9.52	10	11	12	12.7	-	40	63	60	3	M4x10	18	25	
50A	6.35	7	8	9	9.52	10	11	12	12.7	-	50	60	60	3	M4x10	18	25	
50B	6.35	7	8	9	9.52	10	11	12	12.7	14	50	65	60	3	M5x12	23	30	
50BH	6.35	7	8	9	9.52	10	11	12	12.7	14	50	65	65	3	5.5	25	32	
50C	6.35	7	8	9	9.52	10	11	12	12.7	14	50	70	60	3	M4x10	23	30	
55MH	6.35	7	8	9	9.52	10	11	12	12.7	-	55	80	65	2	5.5	16	23	
60A	6.35	7	8	9	9.52	10	11	12	12.7	-	60	75	63	3	M5x12	18	25	
60A1	6.35	7	8	9	9.52	10	11	12	12.7	14	60	75	63	3	M5x12	23	30	
60B	6.35	7	8	9	9.52	10	11	12	12.7	14	60	85	75	3	M5x12	23	30	
60C	6.35	7	8	9	9.52	10	11	12	12.7	14	60	90	75	3	M5x12	23	30	
70A	6.35	7	8	9	9.52	10	11	12	12.7	14	70	85	75	3	M6x15	23	30	
70B	6.35	7	8	9	9.52	10	11	12	12.7	14	70	90	75	3	M5x12	23	30	
73A	6.35	7	8	9	9.52	10	11	12	12.7	14	73	98.4	85	3	M5x12	25	32	
80A	6.35	7	8	9	9.52	10	11	12	12.7	14	80	100	85	3	M6x15	23	30	

Please contact us for other motor adapters and input shaft bore.

SL 070

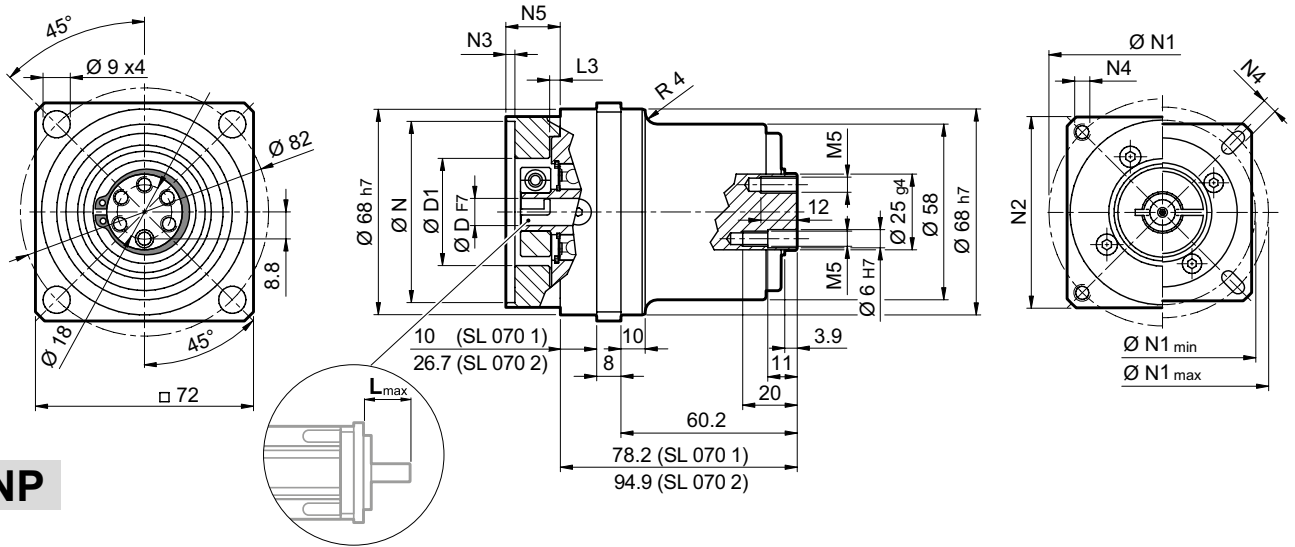

NP

FM

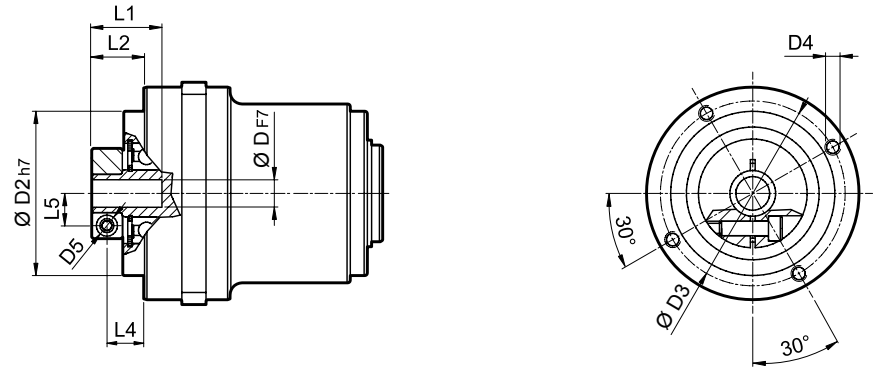

				D1	D2	D3	D4	D5	L1	L2	L3	L4	L5
6.35	7			32.5	50	42.5	M4x8	M4	21.7	13.2	3	8.2	8
8	9	9.52	10	32.5	50	42.5	M4x8	M4	21.7	13.2	3	8.2	9
11	12	12.7		35.5	50	42.5	M4x8	M4	22	13.5	3	8.5	11
14				35.5	50	42.5	M4x8	M4	25	17	3	10.2	11.5

	i	M _{n2}	M _{a2}	M _{p2}	n ₁	n _{1 max}	φ _S	φ _R	C _t	R _{2 max} *	A _{2 max}	η	J _G [kgcm ²]		
		[Nm]	[Nm]	[Nm]	[min ⁻¹]	[min ⁻¹]	[arcmin]	$\frac{Nm}{arcmin}$	[N]	[N]	%		6 ... 9.52	11 ... 14	
SL 070 1_3		18	30	60	3300	4000	12'	6'	6.5	3500	1600	97	0.14	0.16	3.86
SL 070 1_4		25	35	70	3500	5000	12'	6'	6.5	3500	1600	97	0.09	0.11	
SL 070 1_5		25	35	70	3500	5000	12'	6'	6.5	3500	1600	97	0.07	0.09	
SL 070 1_7		25	35	70	3500	5000	12'	6'	6.5	3500	1600	97	0.05	0.07	
SL 070 1_10		18	30	60	4000	6000	12'	6'	6.5	3500	1600	97	0.04	0.06	
SL 070 2_9		18	30	60	3300	4000	15'	8'	6	3500	1600	94	0.11	0.13	
SL 070 2_12		25	35	70	3300	4000	15'	8'	6	3500	1600	94	0.10	0.13	
SL 070 2_15		25	35	70	3300	4000	15'	8'	6	3500	1600	94	0.10	0.12	
SL 070 2_16		25	35	70	3500	5000	15'	8'	6	3500	1600	94	0.07	0.09	
SL 070 2_20		25	35	70	3500	5000	15'	8'	6	3500	1600	94	0.06	0.08	
SL 070 2_25		25	35	70	3500	5000	15'	8'	6	3500	1600	94	0.06	0.08	
SL 070 2_28		25	35	70	4000	6000	15'	8'	6	3500	1600	94	0.05	0.07	
SL 070 2_30		18	30	60	4000	6000	15'	8'	6	3500	1600	94	0.04	0.06	
SL 070 2_35		25	35	70	4000	6000	15'	8'	6	3500	1600	94	0.05	0.07	
SL 070 2_40		25	35	70	4000	6000	15'	8'	6	3500	1600	94	0.04	0.06	
SL 070 2_50		25	35	70	4000	6000	15'	8'	6	3500	1600	94	0.04	0.06	
SL 070 2_70		25	35	70	4000	6000	15'	8'	6	3500	1600	94	0.04	0.06	
SL 070 2_100		18	30	60	4000	6000	15'	8'	6	3500	1600	94	0.04	0.06	

* Applies for timing belt application

S-M-BOR-NL-CAFS-001-V01

SL

SL 090

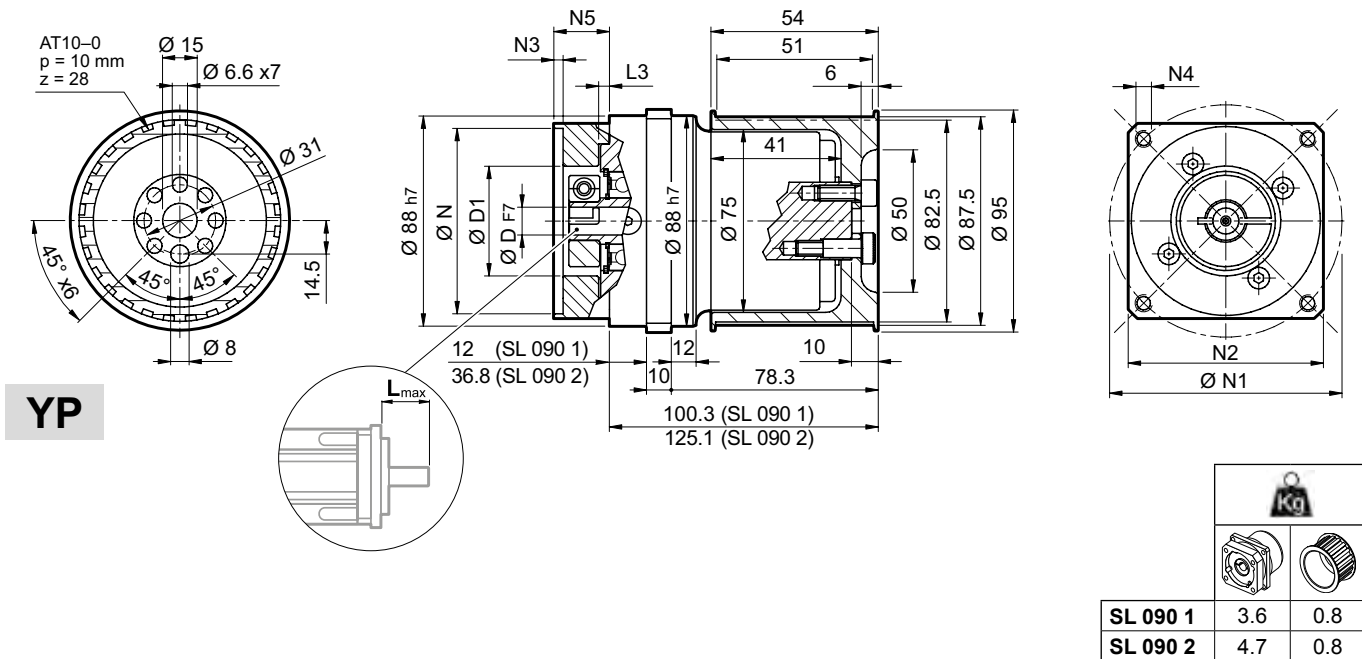

												N	N1	N2	N3	N4	N5	L _{max}
40B1	9	9.52	11	12	12.7	14	-	-	-	-	-	40	63	80	4	M4x10	34	40
45A	9	9.52	11	12	12.7	-	-	-	-	-	-	45	63	80	4	M4x10	34	40
50B1	9	9.52	11	12	12.7	14	-	-	-	-	-	50	65	80	4	M5x16	34	40
50BH1	9	9.52	11	12	12.7	14	-	-	-	-	-	50	65	80	4	5.5	34	40
50C1	9	9.52	11	12	12.7	14	-	-	-	-	-	50	70	80	4	M4x10	34	40
50D	9	9.52	11	12	12.7	14	-	-	-	-	-	50	95	80	4	M6x10	34	40
55A	9	9.52	11	12	12.7	14	15.875	16	17	19	19.05	55.5	125.7	105	4	M6x16	34	40
60A2	9	9.52	11	12	12.7	14	-	-	-	-	-	60	75	80	4	M5x16	34	40
60AH2	9	9.52	11	12	12.7	14	-	-	-	-	-	60	75	90	4	5.5	34	40
60B1	9	9.52	11	12	12.7	14	15.875	16	-	-	-	60	85	80	4	M5x16	34	40
60C1	9	9.52	11	12	12.7	14	15.875	16	-	-	-	60	90	80	4	M5x16	34	40
70A1	9	9.52	11	12	12.7	14	15.875	16	17	19	19.05	70	85	80	4	M6x20	34	40
70AH1	9	9.52	11	12	12.7	14	15.875	16	17	19	19.05	70	85	90	4	6.5	34	40
70B1	9	9.52	11	12	12.7	14	15.875	16	17	19	19.05	70	90	80	4	M5x16	34	40
73A1	9	9.52	11	12	12.7	14	-	-	-	-	-	73	98.4	85	4	M5x16	34	40
80A1	9	9.52	11	12	12.7	14	15.875	16	17	19	19.05	80	100	90	4	M6x16	34	40
95A	9	9.52	11	12	12.7	14	15.875	16	17	19	19.05	95	115	100	4	M8x20	34	40
95B	9	9.52	11	12	12.7	14	15.875	16	17	19	19.05	95	130	115	4	M8x20	34	40
110A	9	9.52	11	12	12.7	14	15.875	16	17	19	19.05	110	130	115	4	M8x20	34	40
110B	9	9.52	11	12	12.7	14	15.875	16	17	19	19.05	110	145	120	6.5	M8x20	44	50
110B1	9	9.52	11	12	12.7	14	15.875	16	17	19	19.05	110	145	120	6.5	M8x20	54	60

Please contact us for other motor adapters and input shaft bore.

SL 090

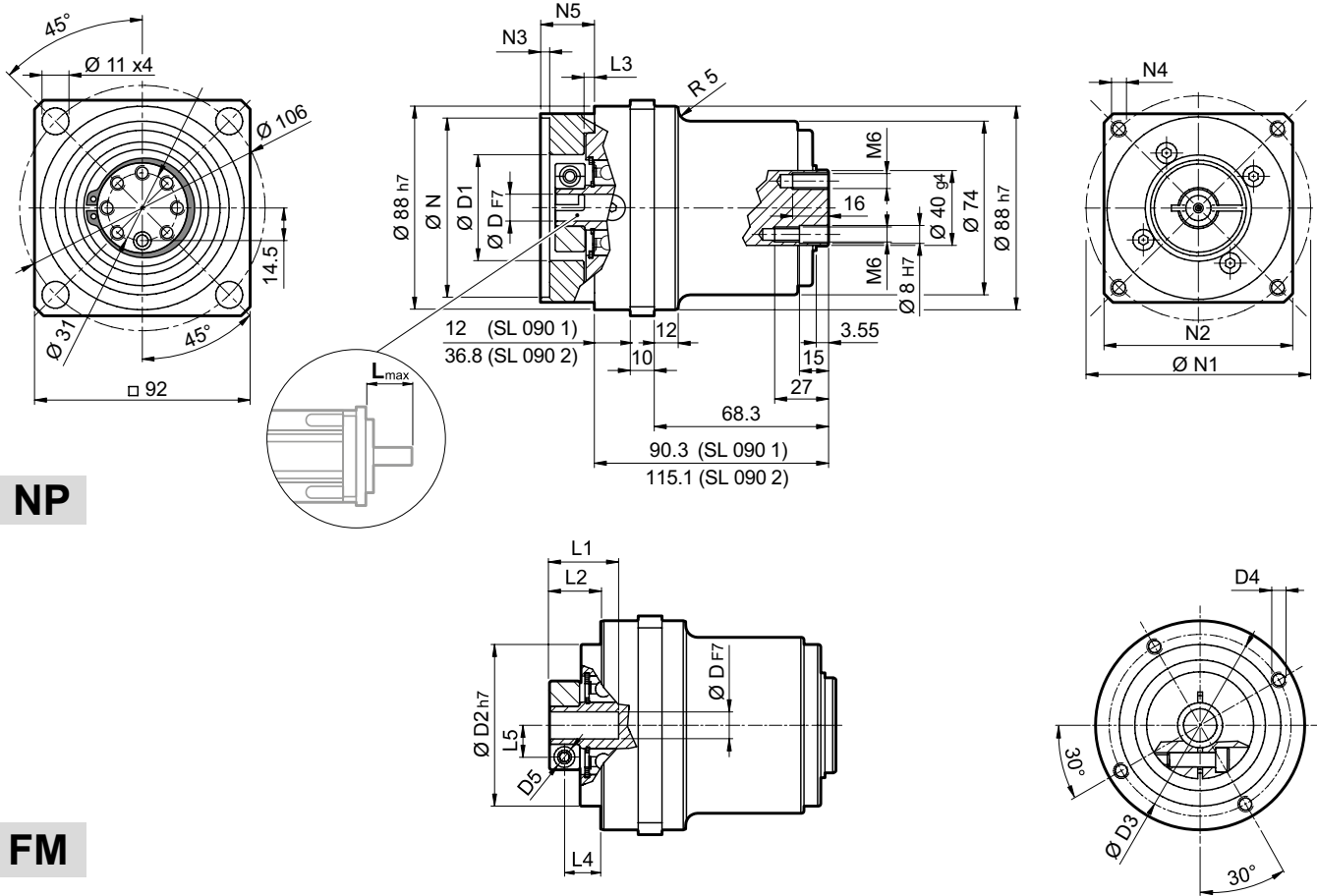

NP

FM

D				D1	D2	D3	D4	D5	L1	L2	L3	L4	L5
9	9.52			38	68	76.5	M6x10	M6	34	26.8	9.5	18.8	10.5
11	12	12.7		52	68	76.5	M6x10	M6	34	26.8	9.5	18.8	12.5
14	15.875	16	17	48	68	76.5	M6x10	M6	34	26.8	9.5	18.8	14.5
19	19.05			51	68	76.5	M6x10	M6	34	26.8	9.5	18.8	16.5

i	M _{n2} [Nm]	M _{a2} [Nm]	M _{p2} [Nm]	n ₁ [min ⁻¹]	n _{1 max} [min ⁻¹]	ψ _s [arcmin]	ψ _R [arcmin]	C _t [Nm/arcmin]	R _{2 max} * [N]	A _{2 max} [N]	η %	J _G [kgcm ²]		10.95
												D		
SL 090 1_3	37	70	150	2900	3500	12'	6'	12	4500	2000	97	9 ... 12.7	14 ... 19	10.95
SL 090 1_4	43	80	160	3100	4500	12'	6'	12	4500	2000	97	0.72	0.81	
SL 090 1_5	43	80	160	3200	4500	12'	6'	12	4500	2000	97	0.49	0.58	
SL 090 1_7	43	80	160	4000	6000	12'	6'	12	4500	2000	97	0.39	0.48	
SL 090 1_10	37	70	150	4000	6000	12'	6'	12	4500	2000	97	0.31	0.40	
SL 090 2_9	37	70	150	2900	3500	15'	8'	11.5	4500	2000	94	0.27	0.35	
SL 090 2_12	43	80	160	2900	3500	15'	8'	11.5	4500	2000	94	0.47	0.61	
SL 090 2_15	43	80	160	2900	3500	15'	8'	11.5	4500	2000	94	0.44	0.58	
SL 090 2_16	43	80	160	2900	3500	15'	8'	11.5	4500	2000	94	0.43	0.57	
SL 090 2_20	43	80	160	3100	4500	15'	8'	11.5	4500	2000	94	0.31	0.45	
SL 090 2_25	43	80	160	3200	4500	15'	8'	11.5	4500	2000	94	0.26	0.40	
SL 090 2_28	43	80	160	3200	4500	15'	8'	11.5	4500	2000	94	0.26	0.40	
SL 090 2_30	43	80	160	4000	6000	15'	8'	11.5	4500	2000	94	0.22	0.36	
SL 090 2_35	37	70	150	4000	6000	15'	8'	11.5	4500	2000	94	0.22	0.36	
SL 090 2_40	43	80	160	4000	6000	15'	8'	11.5	4500	2000	94	0.20	0.34	
SL 090 2_50	43	80	160	4000	6000	15'	8'	11.5	4500	2000	94	0.20	0.34	
SL 090 2_70	43	80	160	4000	6000	15'	8'	11.5	4500	2000	94	0.20	0.34	
SL 090 2_100	37	70	150	4000	6000	15'	8'	11.5	4500	2000	94	0.20	0.34	

* Applies for timing belt application

SL 120

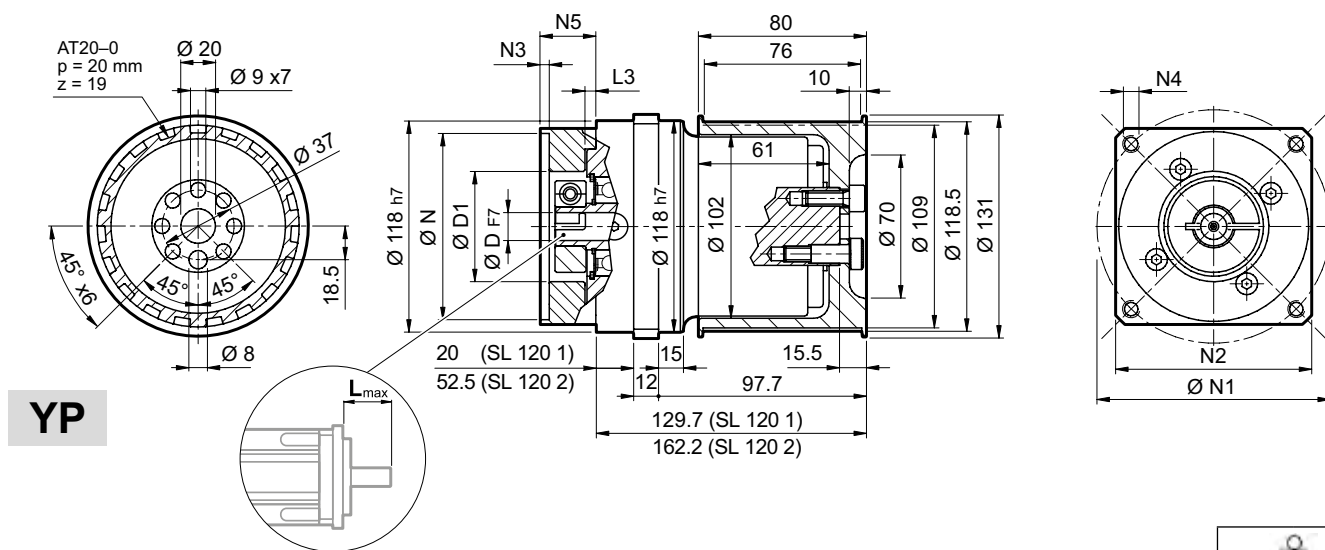

SL 120 1	8.4	2.6
SL 120 2	10.9	2.6

									N	N1	N2	N3	N4	N5	L _{max}
50D	14	15	15.875	16	19	-	-	-	50	95	100	5	M6x14	28	40
55A	14	15	15.875	16	19	-	-	-	55.5	125.7	105	5	M6x16	28	40
60A2	14	15	15.875	16	19	-	-	-	60	75	100	5	M5x14	28	40
60AH2	14	15	15.875	16	19	-	-	-	60	75	100	5	6.5	33	40
60B1	14	15	15.875	16	19	-	-	-	60	85	100	6.5	M5x14	28	40
70A1	14	15	15.875	16	19	-	-	-	70	85	100	5	M6x14	28	40
70AH1	14	15	15.875	16	19	-	-	-	70	85	100	5	6	33	40
70B1	14	15	15.875	16	19	-	-	-	70	90	100	5	M5x12	28	40
80A1	14	15	15.875	16	19	-	-	-	80	100	100	5	M6x16	28	40
80AH1	14	15	15.875	16	19	-	-	-	80	100	100	5	6.5	28	40
95A	14	15	15.875	16	19	-	-	-	95	115	100	5	M8x18	28	40
95A1	14	15	15.875	16	19	22	24	-	95	115	100	5	M8x18	38	50
95B	14	15	15.875	16	19	-	-	-	95	130	115	5	M8x18	28	40
110A	14	15	15.875	16	19	-	-	-	110	130	115	5	M8x18	28	40
110A1	14	15	15.875	16	19	22	24	-	110	130	115	6.5	M8x20	38	50
110B	14	15	15.875	16	19	22	24	-	110	145	120	6.5	M8x20	38	50
110B1	14	15	15.875	16	19	22	24	28	110	145	120	6.5	M8x20	48	60
130A	14	15	15.875	16	19	22	24	-	130	165	140	6.5	M10x20	38	50
130A1	14	15	15.875	16	19	22	24	28	130	165	140	6.5	M10x25	48	60

Please contact us for other motor adapters and input shaft bore.

SL 120

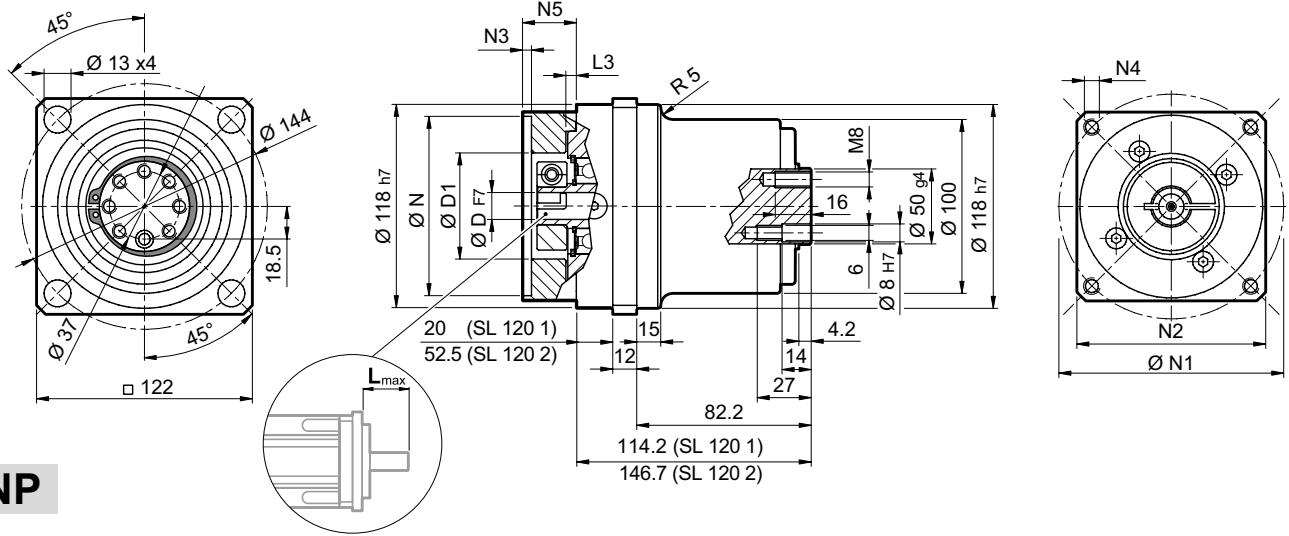

NP

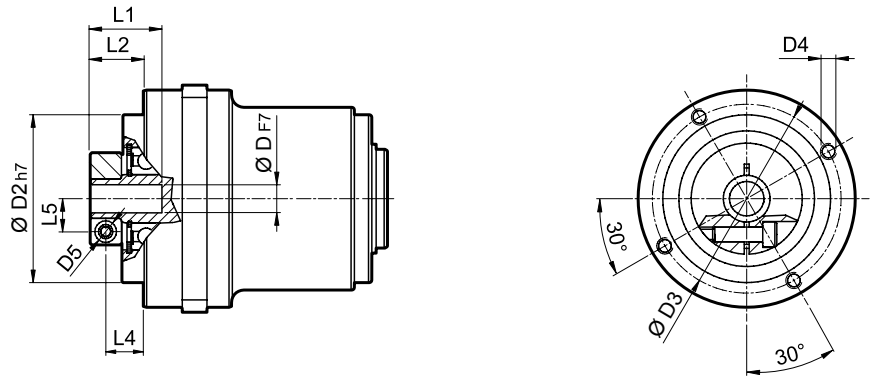

FM

				D1	D2	D3	D4	D5	L1	L2	L3	L4	L5
14	15	15.875	16	48	90	98	M6x15	M6	33.5	20	7.6	12.5	14.5
19				51	90	98	M6x15	M6	33.5	20	7.6	12.5	16.5
22	24			56.5	90	98	M6x15	M6	36.5	23	7.6	14	19
28				70	90	98	M6x15	M8	36.5	23	7.6	14	22.5
32				71	90	98	M6x15	M8	38	24.5	7.6	15.5	24.5

	i	M _{n2} [Nm]	M _{a2} [Nm]	M _{p2} [Nm]	n ₁ [min ⁻¹]	n _{1 max} [min ⁻¹]	φ _S [arcmin]	φ _R [arcmin]	C _t [$\frac{Nm}{arcmin}$]	R _{2 max} * [N]	A _{2 max} [N]	η %	J _G [kgcm ²]			
													14 ... 19	22 ; 24	28 ; 32	
SL 120 1_3	95	160	300	2500	3500	12'	6'	45	10000	4500	97	2.18	2.81	3.25	50.62	
SL 120 1_4	110	190	360	2800	4500	12'	6'	45	10000	4500	97	1.30	1.93	2.37		
SL 120 1_5	110	190	360	3000	4500	12'	6'	45	10000	4500	97	0.96	1.59	2.03		
SL 120 1_7	110	190	360	3500	4500	12'	6'	45	10000	4500	97	0.66	1.28	1.72		
SL 120 1_10	95	160	300	3500	5000	12'	6'	45	10000	4500	97	0.49	1.11	1.55		
SL 120 2_9	95	160	300	2500	3500	15'	8'	40	10000	4500	94	1.61	2.20	2.57		
SL 120 2_12	110	190	360	2500	3500	15'	8'	40	10000	4500	94	1.51	2.10	2.47		
SL 120 2_15	110	190	360	2500	3500	15'	8'	40	10000	4500	94	1.47	2.06	2.43		
SL 120 2_16	110	190	360	2800	4500	15'	8'	40	10000	4500	94	0.92	1.52	1.88		
SL 120 2_20	110	190	360	3000	4500	15'	8'	40	10000	4500	94	0.90	1.50	1.86		
SL 120 2_25	110	190	360	3000	4500	15'	8'	40	10000	4500	94	0.71	1.30	1.67		
SL 120 2_28	110	190	360	3500	5000	15'	8'	40	10000	4500	94	0.54	1.13	1.50		
SL 120 2_30	95	160	300	3500	5000	15'	8'	40	10000	4500	94	0.44	1.04	1.40		
SL 120 2_35	110	190	360	3500	5000	15'	8'	40	10000	4500	94	0.53	1.13	1.49		
SL 120 2_40	110	190	360	3500	5000	15'	8'	40	10000	4500	94	0.43	1.03	1.39		
SL 120 2_50	110	190	360	3500	5000	15'	8'	40	10000	4500	94	0.43	1.02	1.39		
SL 120 2_70	110	190	360	3500	5000	15'	8'	40	10000	4500	94	0.42	1.02	1.38		
SL 120 2_100	95	160	300	3500	5000	15'	8'	40	10000	4500	94	0.42	1.02	1.38		

* Applies for timing belt application

SL 070P

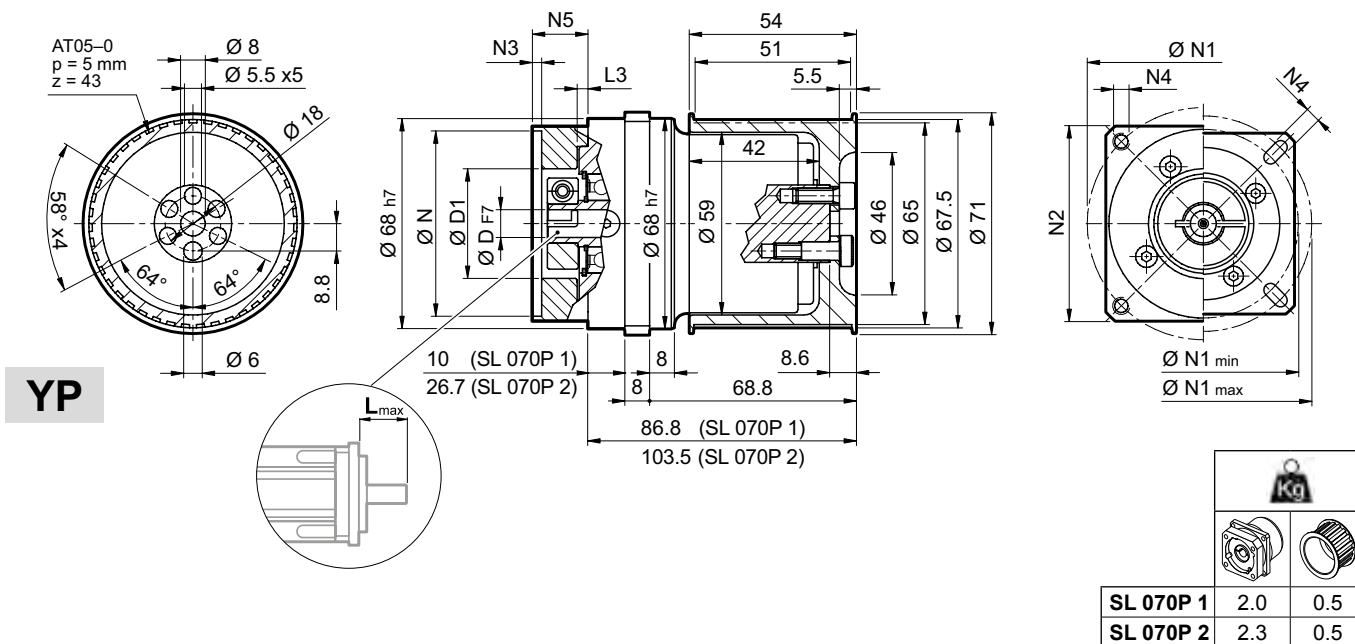

		D											N	N1		N2	N3	N4	N5	L _{max}
															min					
25AH	6.35	7	8	9	9.52	-	-	-	-	-	25	39	56							
26AH	6.35	7	8	9	9.52	-	-	-	-	-	26	39	56							
28AH	6.35	7	8	9	9.52	-	-	-	-	-	28	39	56							
30AH	6.35	7	8	9	9.52	-	-	-	-	-	30	39	56							
32AH	6.35	7	8	9	9.52	-	-	-	-	-	32	39	56	65	3.5	4.5	25	25		
34AH	6.35	7	8	9	9.52	-	-	-	-	-	34	40	56							
36AH	6.35	7	8	9	9.52	-	-	-	-	-	36	42	56							
39AH	6.35	7	8	9	9.52	-	-	-	-	-	39	45	56							
40AH	6.35	7	8	9	9.52	-	-	-	-	-	40	46	56							
38B	6.35	7	8	9	9.52	10	11	12	12.7	-	38.1	66.6	60	3	M4x10	18	25			
40B	6.35	7	8	9	9.52	10	11	12	12.7	-	40	63	60	3	M4x10	18	25			
50A	6.35	7	8	9	9.52	10	11	12	12.7	-	50	60	60	3	M4x10	18	25			
50B	6.35	7	8	9	9.52	10	11	12	12.7	14	50	65	60	3	M5x12	23	30			
50BH	6.35	7	8	9	9.52	10	11	12	12.7	14	50	65	65	3	5.5	25	32			
50C	6.35	7	8	9	9.52	10	11	12	12.7	14	50	70	60	3	M4x10	23	30			
55MH	6.35	7	8	9	9.52	10	11	12	12.7	-	55	80	65	2	5.5	16	23			
60A	6.35	7	8	9	9.52	10	11	12	12.7	-	60	75	63	3	M5x12	18	25			
60A1	6.35	7	8	9	9.52	10	11	12	12.7	14	60	75	63	3	M5x12	23	30			
60B	6.35	7	8	9	9.52	10	11	12	12.7	14	60	85	75	3	M5x12	23	30			
60C	6.35	7	8	9	9.52	10	11	12	12.7	14	60	90	75	3	M5x12	23	30			
70A	6.35	7	8	9	9.52	10	11	12	12.7	14	70	85	75	3	M6x15	23	30			
70B	6.35	7	8	9	9.52	10	11	12	12.7	14	70	90	75	3	M5x12	23	30			
73A	6.35	7	8	9	9.52	10	11	12	12.7	14	73	98.4	85	3	M5x12	25	32			
80A	6.35	7	8	9	9.52	10	11	12	12.7	14	80	100	85	3	M6x15	23	30			

Please contact us for other motor adapters and input shaft bore.

SL 070P

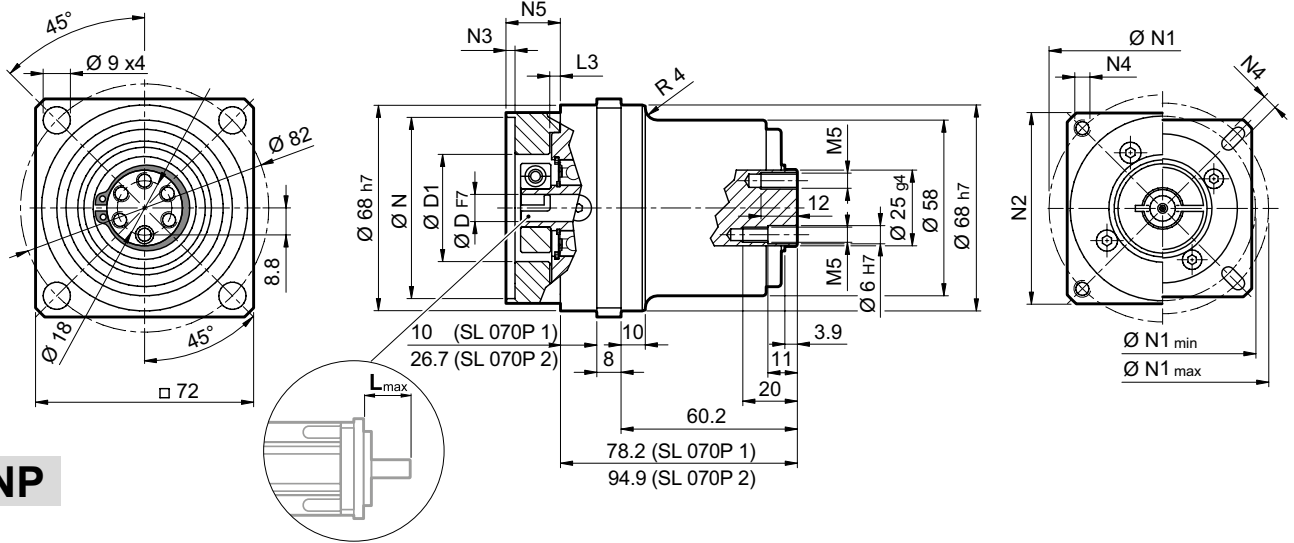

NP

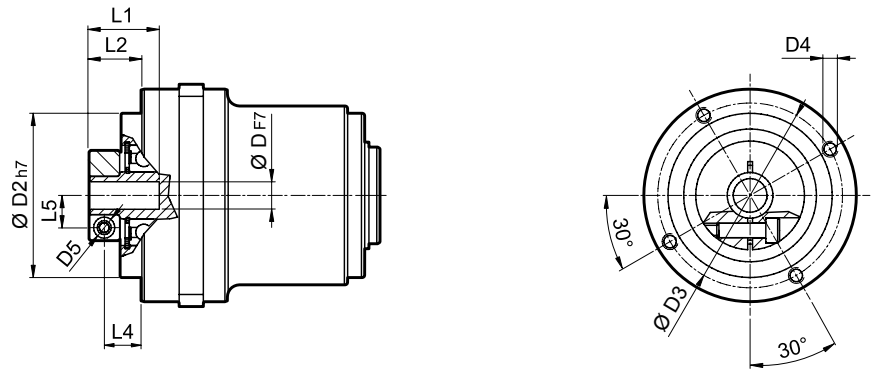

FM

D				D1	D2	D3	D4	D5	L1	L2	L3	L4	L5
6.35	7			32.5	50	42.5	M4x8	M4	21.7	13.2	3	8.2	8
8	9	9.52	10	32.5	50	42.5	M4x8	M4	21.7	13.2	3	8.2	9
11	12	12.7		35.5	50	42.5	M4x8	M4	22	13.5	3	8.5	11
14				35.5	50	42.5	M4x8	M4	25	17	3	10.2	11.5

i	M _{n2} [Nm]	M _{a2} [Nm]	M _{p2} [Nm]	n ₁ [min ⁻¹]	n _{1 max} [min ⁻¹]	φ _s [arcmin]	φ _R	C _t [Nm/arcmin]	R _{2 max} * [N]	A _{2 max} [N]	η %	J _G [kgcm ²]		D
												6 ... 9.52	11 ... 14	
SL 070P 1_3	29	55	60	3300	4000	12'	6'	6.5	3500	1600	97	0.14	0.16	3.86
SL 070P 1_4	30	45	70	3500	5000	12'	6'	6.5	3500	1600	97	0.09	0.11	
SL 070P 1_5	25	40	70	3500	5000	12'	6'	6.5	3500	1600	97	0.07	0.09	
SL 070P 1_7	25	40	70	4000	5000	12'	6'	6.5	3500	1600	97	0.05	0.07	
SL 070P 1_10	18	30	60	4000	6000	12'	6'	6.5	3500	1600	97	0.04	0.06	
SL 070P 2_9	29	55	60	3300	4000	15'	8'	6	3500	1600	94	0.11	0.13	
SL 070P 2_12	29	55	70	3300	4000	15'	8'	6	3500	1600	94	0.10	0.13	
SL 070P 2_15	29	55	70	3300	4000	15'	8'	6	3500	1600	94	0.10	0.12	
SL 070P 2_16	30	45	70	3500	5000	15'	8'	6	3500	1600	94	0.07	0.09	
SL 070P 2_20	30	45	70	3500	5000	15'	8'	6	3500	1600	94	0.06	0.08	
SL 070P 2_25	30	45	70	3500	5000	15'	8'	6	3500	1600	94	0.06	0.08	
SL 070P 2_28	30	45	70	4000	6000	15'	8'	6	3500	1600	94	0.05	0.07	
SL 070P 2_30	29	55	60	4000	6000	15'	8'	6	3500	1600	94	0.04	0.06	
SL 070P 2_35	30	45	70	4000	6000	15'	8'	6	3500	1600	94	0.05	0.07	
SL 070P 2_40	30	45	70	4000	6000	15'	8'	6	3500	1600	94	0.04	0.06	
SL 070P 2_50	30	45	70	4000	6000	15'	8'	6	3500	1600	94	0.04	0.06	
SL 070P 2_70	30	45	70	4000	6000	15'	8'	6	3500	1600	94	0.04	0.06	
SL 070P 2_100	18	30	60	4000	6000	15'	8'	6	3500	1600	94	0.04	0.06	

* Applies for timing belt application

SL 090P

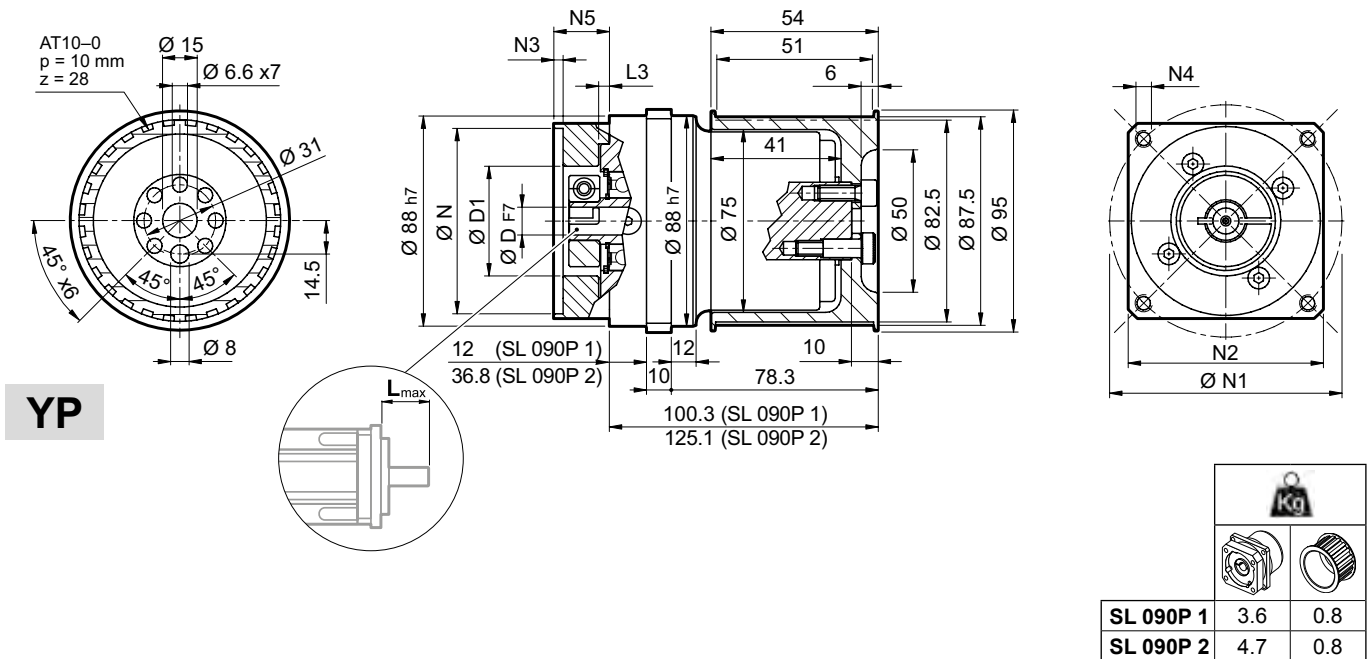

												N	N1	N2	N3	N4	N5	L _{max}
40B1	9	9.52	11	12	12.7	14	-	-	-	-	-	40	63	80	4	M4x10	34	40
45A	9	9.52	11	12	12.7	-	-	-	-	-	-	45	63	80	4	M4x10	34	40
50B1	9	9.52	11	12	12.7	14	-	-	-	-	-	50	65	80	4	M5x16	34	40
50BH1	9	9.52	11	12	12.7	14	-	-	-	-	-	50	65	80	4	5.5	34	40
50C1	9	9.52	11	12	12.7	14	-	-	-	-	-	50	70	80	4	M4x10	34	40
50D	9	9.52	11	12	12.7	14	-	-	-	-	-	50	95	80	4	M6x10	34	40
55A	9	9.52	11	12	12.7	14	15.875	16	17	19	19.05	55.5	125.7	105	4	M6x16	34	40
60A2	9	9.52	11	12	12.7	14	-	-	-	-	-	60	75	80	4	M5x16	34	40
60AH2	9	9.52	11	12	12.7	14	-	-	-	-	-	60	75	90	4	5.5	34	40
60B1	9	9.52	11	12	12.7	14	15.875	16	-	-	-	60	85	80	4	M5x16	34	40
60C1	9	9.52	11	12	12.7	14	15.875	16	-	-	-	60	90	80	4	M5x16	34	40
70A1	9	9.52	11	12	12.7	14	15.875	16	17	19	19.05	70	85	80	4	M6x20	34	40
70AH1	9	9.52	11	12	12.7	14	15.875	16	17	19	19.05	70	85	90	4	6.5	34	40
70B1	9	9.52	11	12	12.7	14	15.875	16	17	19	19.05	70	90	80	4	M5x16	34	40
73A1	9	9.52	11	12	12.7	14	-	-	-	-	-	73	98.4	85	4	M5x16	34	40
80A1	9	9.52	11	12	12.7	14	15.875	16	17	19	19.05	80	100	90	4	M6x16	34	40
95A	9	9.52	11	12	12.7	14	15.875	16	17	19	19.05	95	115	100	4	M8x20	34	40
95B	9	9.52	11	12	12.7	14	15.875	16	17	19	19.05	95	130	115	4	M8x20	34	40
110A	9	9.52	11	12	12.7	14	15.875	16	17	19	19.05	110	130	115	4	M8x20	34	40
110B	9	9.52	11	12	12.7	14	15.875	16	17	19	19.05	110	145	120	6.5	M8x20	44	50
110B1	9	9.52	11	12	12.7	14	15.875	16	17	19	19.05	110	145	120	6.5	M8x20	54	60

Please contact us for other motor adapters and input shaft bore.

SL 090P

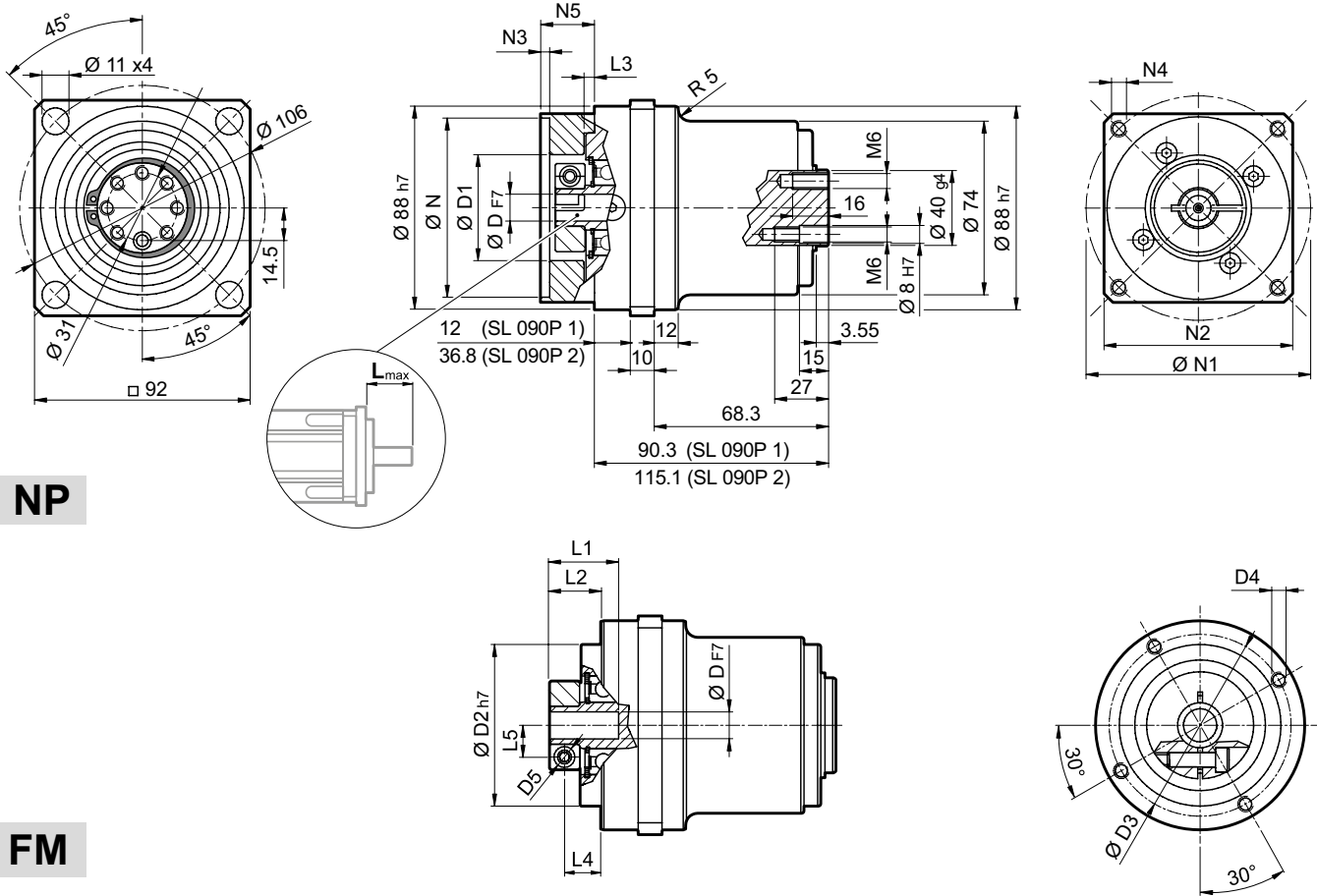

NP

FM

D				D1	D2	D3	D4	D5	L1	L2	L3	L4	L5
9	9.52			38	68	76.5	M6x10	M6	34	26.8	9.5	18.8	10.5
11	12	12.7		52	68	76.5	M6x10	M6	34	26.8	9.5	18.8	12.5
14	15.875	16	17	48	68	76.5	M6x10	M6	34	26.8	9.5	18.8	14.5
19	19.05			51	68	76.5	M6x10	M6	34	26.8	9.5	18.8	16.5

i	M _{n2} [Nm]	M _{a2} [Nm]	M _{p2} [Nm]	n ₁ [min ⁻¹]	n _{1 max} [min ⁻¹]	ψ _s [arcmin]	ψ _R [arcmin]	C _t [Nm/arcmin]	R _{2 max} * [N]	A _{2 max} [N]	η [%]	J _G [kgcm ²]		10.95
												D		
SL 090P 1_3	65	120	150	3500	4000	12'	6'	12	4500	2000	97	0.72	0.81	10.95
SL 090P 1_4	60	110	160	3500	4000	12'	6'	12	4500	2000	97	0.49	0.58	
SL 090P 1_5	50	100	160	3200	4500	12'	6'	12	4500	2000	97	0.39	0.48	
SL 090P 1_7	50	100	160	4000	6000	12'	6'	12	4500	2000	97	0.31	0.40	
SL 090P 1_10	40	70	150	4000	6000	12'	6'	12	4500	2000	97	0.27	0.35	
SL 090P 2_9	65	120	150	3500	3500	15'	8'	11.5	4500	2000	94	0.47	0.61	
SL 090P 2_12	65	120	160	3500	3500	15'	8'	11.5	4500	2000	94	0.44	0.58	
SL 090P 2_15	65	120	160	3500	3500	15'	8'	11.5	4500	2000	94	0.43	0.57	
SL 090P 2_16	60	110	160	3500	4500	15'	8'	11.5	4500	2000	94	0.31	0.45	
SL 090P 2_20	60	110	160	3500	4500	15'	8'	11.5	4500	2000	94	0.26	0.40	
SL 090P 2_25	50	100	160	3200	4500	15'	8'	11.5	4500	2000	94	0.26	0.40	
SL 090P 2_28	50	100	160	4000	6000	15'	8'	11.5	4500	2000	94	0.22	0.36	
SL 090P 2_30	65	120	150	4000	6000	15'	8'	11.5	4500	2000	94	0.20	0.34	
SL 090P 2_35	50	100	160	4000	6000	15'	8'	11.5	4500	2000	94	0.22	0.36	
SL 090P 2_40	60	110	160	4000	6000	15'	8'	11.5	4500	2000	94	0.20	0.34	
SL 090P 2_50	50	100	160	4000	6000	15'	8'	11.5	4500	2000	94	0.20	0.34	
SL 090P 2_70	50	100	160	4000	6000	15'	8'	11.5	4500	2000	94	0.20	0.34	
SL 090P 2_100	40	70	150	4000	6000	15'	8'	11.5	4500	2000	94	0.19	0.34	

* Applies for timing belt application

SL 120P

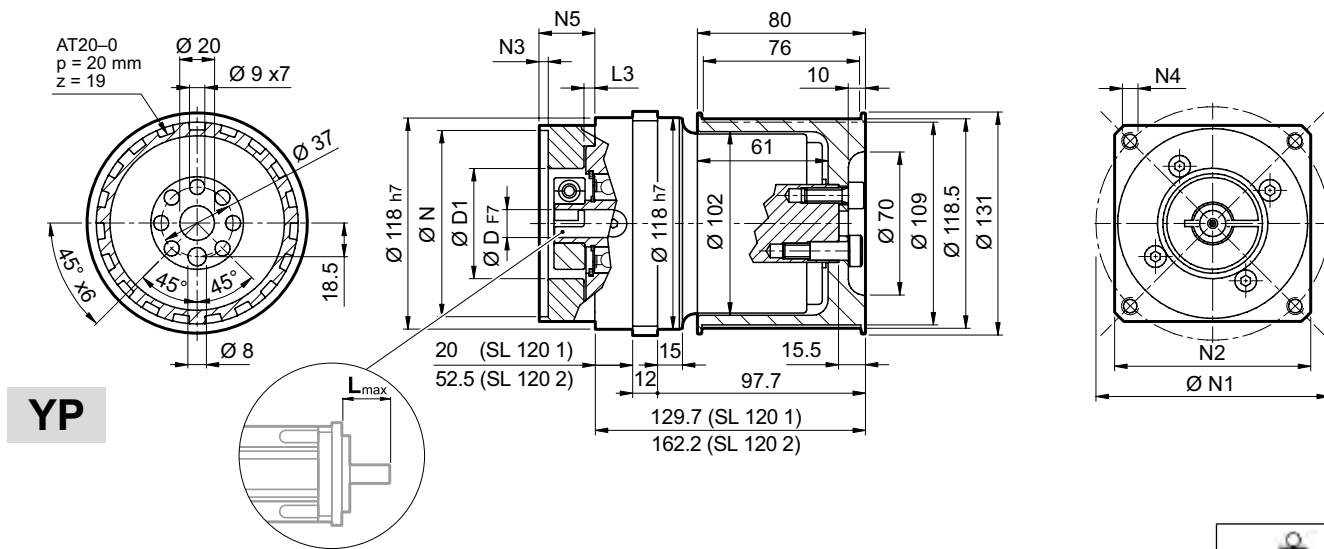

SL 120P 1	8.4	2.6
SL 120P 2	10.9	2.6

									N	N1	N2	N3	N4	N5	L _{max}
50D	14	15	15.875	16	19	-	-	-	50	95	100	5	M6x14	28	40
55A	14	15	15.875	16	19	-	-	-	55.5	125.7	105	5	M6x16	28	40
60A2	14	15	15.875	16	19	-	-	-	60	75	100	5	M5x14	28	40
60AH2	14	15	15.875	16	19	-	-	-	60	75	100	5	6.5	33	40
60B1	14	15	15.875	16	19	-	-	-	60	85	100	6.5	M5x14	28	40
70A1	14	15	15.875	16	19	-	-	-	70	85	100	5	M6x14	28	40
70AH1	14	15	15.875	16	19	-	-	-	70	85	100	5	6	33	40
70B1	14	15	15.875	16	19	-	-	-	70	90	100	5	M5x12	28	40
80A1	14	15	15.875	16	19	-	-	-	80	100	100	5	M6x16	28	40
80AH1	14	15	15.875	16	19	-	-	-	80	100	100	5	6.5	28	40
95A	14	15	15.875	16	19	-	-	-	95	115	100	5	M8x18	28	40
95A1	14	15	15.875	16	19	22	24	-	95	115	100	5	M8x18	38	50
95B	14	15	15.875	16	19	-	-	-	95	130	115	5	M8x18	28	40
110A	14	15	15.875	16	19	-	-	-	110	130	115	5	M8x18	28	40
110A1	14	15	15.875	16	19	22	24	-	110	130	115	6.5	M8x20	38	50
110B	14	15	15.875	16	19	22	24	-	110	145	120	6.5	M8x20	38	50
110B1	14	15	15.875	16	19	22	24	28	110	145	120	6.5	M8x20	48	60
130A	14	15	15.875	16	19	22	24	-	130	165	140	6.5	M10x20	38	50
130A1	14	15	15.875	16	19	22	24	28	130	165	140	6.5	M10x25	48	60

Please contact us for other motor adapters and input shaft bore.

SL 120P

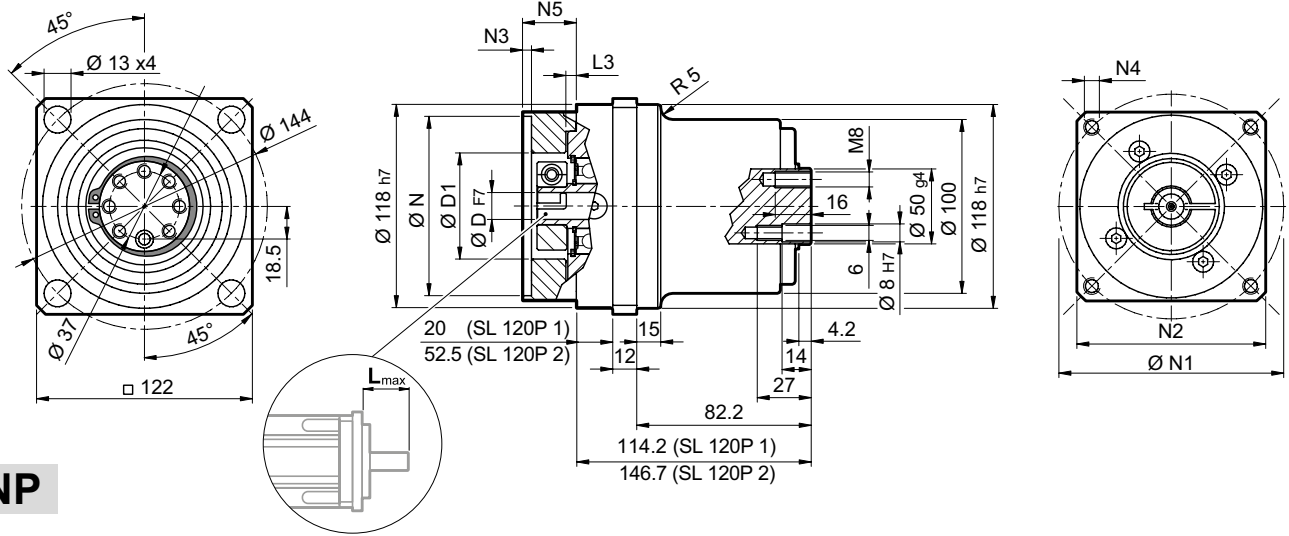

NP

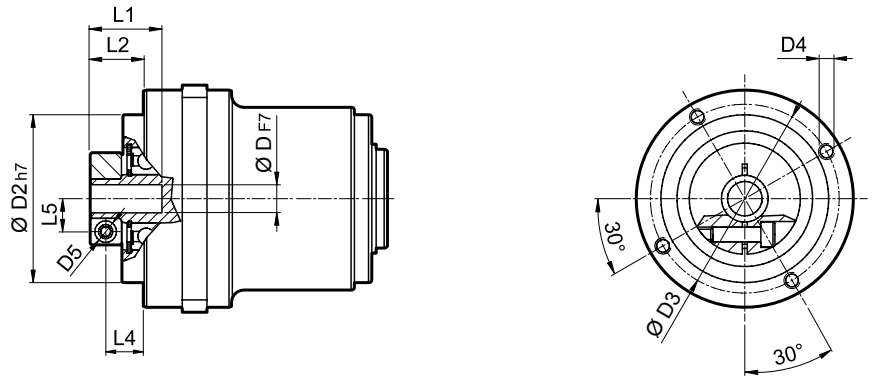

FM

D				D1	D2	D3	D4	D5	L1	L2	L3	L4	L5
14	15	15.875	16	48	90	98	M6x15	M6	33.5	20	7.6	12.5	14.5
19				51	90	98	M6x15	M6	33.5	20	7.6	12.5	16.5
22	24			56.5	90	98	M6x15	M6	36.5	23	7.6	14	19
28				70	90	98	M6x15	M8	36.5	23	7.6	14	22.5
32				71	90	98	M6x15	M8	38	24.5	7.6	15.5	24.5

i	M _{n2} [Nm]	M _{a2} [Nm]	M _{p2} [Nm]	n ₁ [min ⁻¹]	n _{1 max} [min ⁻¹]	φ _S [arcmin]	φ _R [arcmin]	C _t [Nm/arcmin]	R _{2 max} * [N]	A _{2 max} [N]	η [%]	J _G [kgcm ²]			50.62
												D	14 ... 19	22 ; 24	
SL 120P 1_3	155	280	300	3000	4000	12'	6'	45	10000	4500	97	2.18	2.81	3.25	50.62
SL 120P 1_4	155	300	360	3000	4500	12'	6'	45	10000	4500	97	1.30	1.93	2.37	
SL 120P 1_5	125	240	360	3000	4500	12'	6'	45	10000	4500	97	0.96	1.59	2.03	
SL 120P 1_7	125	240	360	3500	4500	12'	6'	45	10000	4500	97	0.66	1.28	1.72	
SL 120P 1_10	100	160	300	3500	5000	12'	6'	45	10000	4500	97	0.49	1.11	1.55	
SL 120P 2_9	155	280	300	3000	4000	15'	8'	40	10000	4500	94	1.61	2.20	2.57	
SL 120P 2_12	155	300	360	3000	4000	15'	8'	40	10000	4500	94	1.51	2.10	2.47	
SL 120P 2_15	155	300	360	3000	4000	15'	8'	40	10000	4500	94	1.47	2.06	2.43	
SL 120P 2_16	155	300	360	3000	4500	15'	8'	40	10000	4500	94	0.92	1.52	1.88	
SL 120P 2_20	155	300	360	3000	4500	15'	8'	40	10000	4500	94	0.90	1.50	1.86	
SL 120P 2_25	125	240	360	3000	4500	15'	8'	40	10000	4500	94	0.71	1.30	1.67	
SL 120P 2_28	125	240	360	3500	5000	15'	8'	40	10000	4500	94	0.54	1.13	1.50	
SL 120P 2_30	155	300	300	3500	5000	15'	8'	40	10000	4500	94	0.44	1.04	1.40	
SL 120P 2_35	125	240	360	3500	5000	15'	8'	40	10000	4500	94	0.53	1.13	1.49	
SL 120P 2_40	155	300	360	3500	5000	15'	8'	40	10000	4500	94	0.43	1.03	1.39	
SL 120P 2_50	125	240	360	3500	5000	15'	8'	40	10000	4500	94	0.43	1.02	1.39	
SL 120P 2_70	125	240	360	3500	5000	15'	8'	40	10000	4500	94	0.42	1.02	1.38	
SL 120P 2_100	100	160	300	3500	5000	15'	8'	40	10000	4500	94	0.42	1.02	1.38	

* Applies for timing belt application

S-M-BOR-NL-CAFS-001-V01

TS

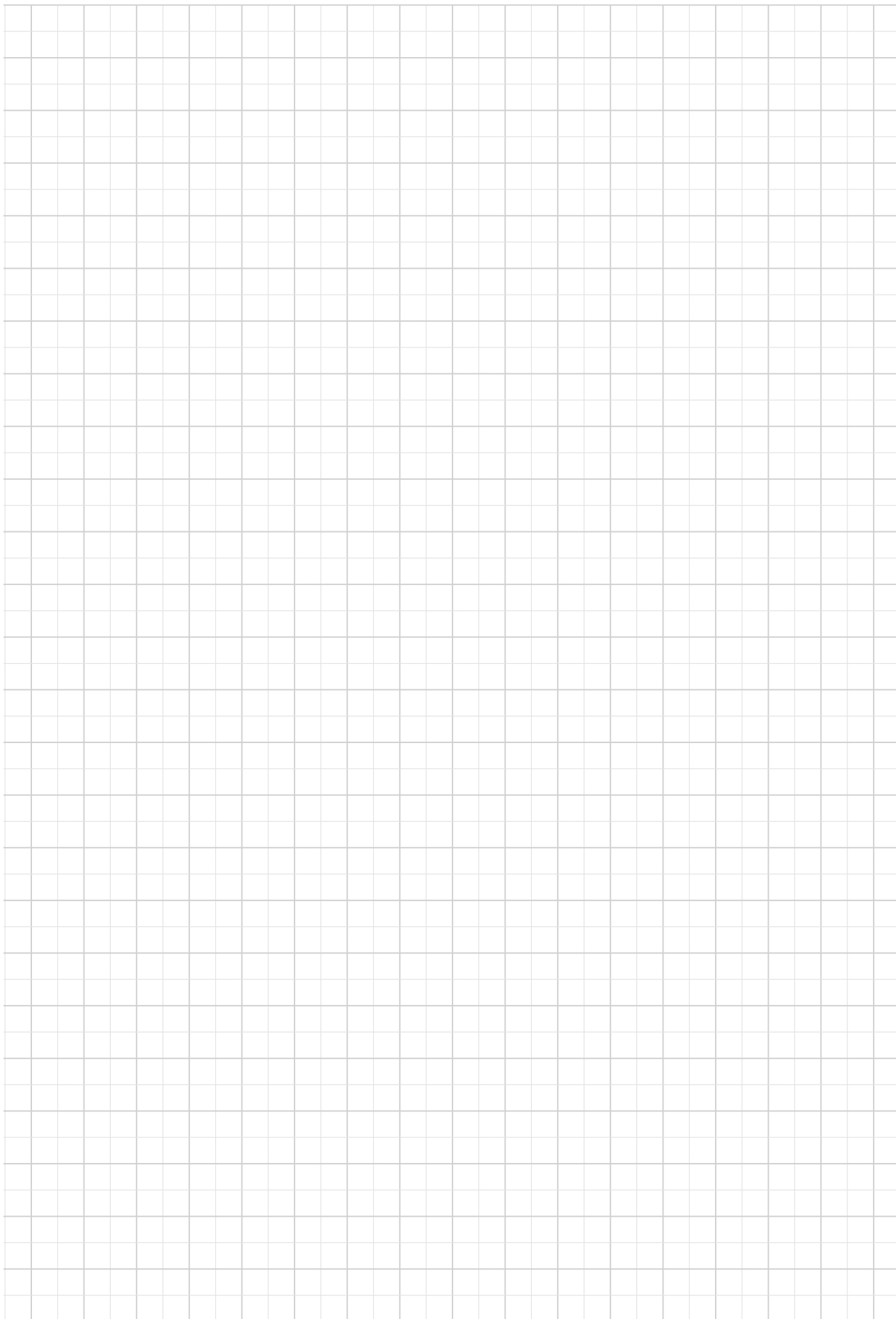

SL

KR PRECISION BEVEL GEARBOX

The flexible, efficient economical solution to applications calling for space saving right angle drives with minimal backlash.

Available in different configurations with numerous input and output configuration.

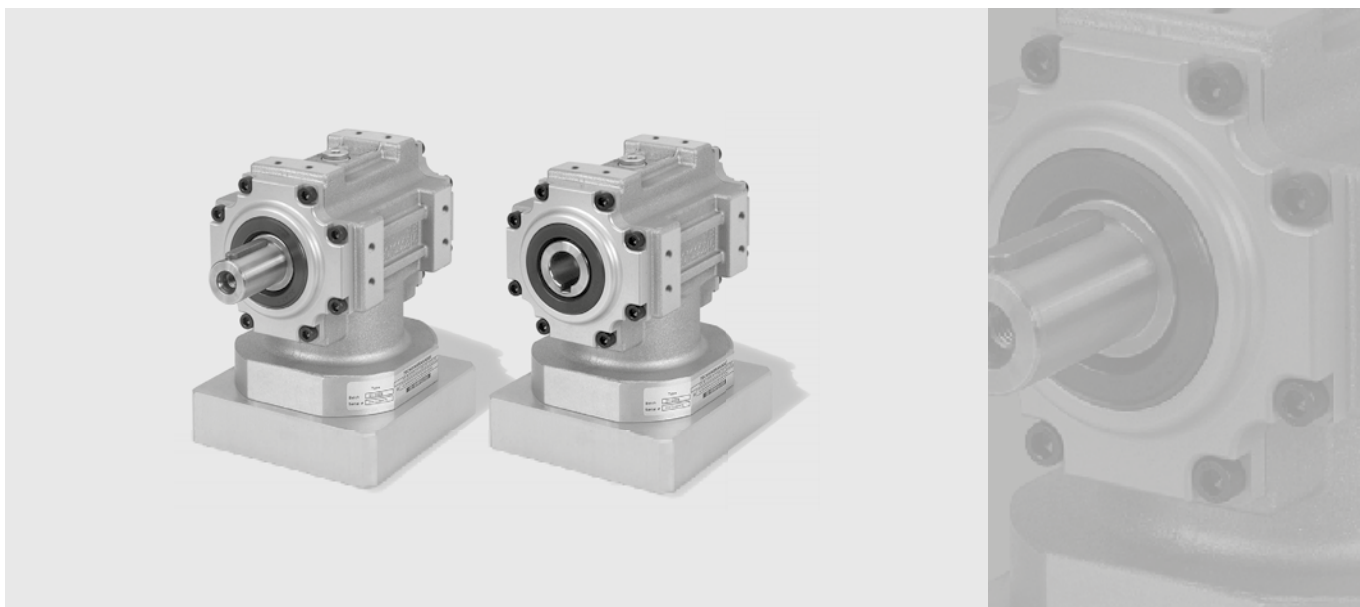

Product Line Up:

- Best Combination of Dynamics, Compactness and Precision
- Designed for Cyclic and Continuous Duty
- Good Torsional Stiffness
- Geometrical Backlash less than 8 arcmin

10 FEATURES OF KR SERIES

Bevel helical units type KR, manufactured under the most stringent quality specifications, are designed for dynamic and accurate applications where light weight and space effectiveness are a factor.

Many options can be selected from the catalogue as far as motor adapters and output shaft configurations that facilitate the installation on the driven equipment.

- Available in one only backlash option ($\varphi_s \leq 8'$)
- Single reduction: ratios $i = 1, 2, 5$
- Radial ball bearings (SB) are of standard supply, while taper roller bearings (HB) can be optionally specified for particularly demanding loading conditions
- Degree of protection IP65
- Oil seals from fluoroelastomer compound as standard
- Noise pressure level $L_p \leq 70$ dB(A). Conditions: distance 1 m; measured without load an input speed of $n_1 = 3000$ min⁻¹
- Lubrication optimized for the type of duty specified when ordering, in the absence of contamination the lubricant requires no periodical changes.

duty	KR 010 ... KR 040
S1 (continuous)	Synthetic oil viscosity ISO VG 220
S5 (intermittent)	NLGI grease consistency 00

- Ambient temperature min -20°C, max +30°C. For temperature higher than 30°C please consider derating factor f_T .
- Housing temperature must not exceed $T_{max} = 90^\circ\text{C}$.

Distribution of nominal torque		M_{n2} [Nm]		
	[i]	1	2	5
KR 010		10	7	3
KR 020		24	15	10
KR 030		55	37	22
KR 040		120	85	45

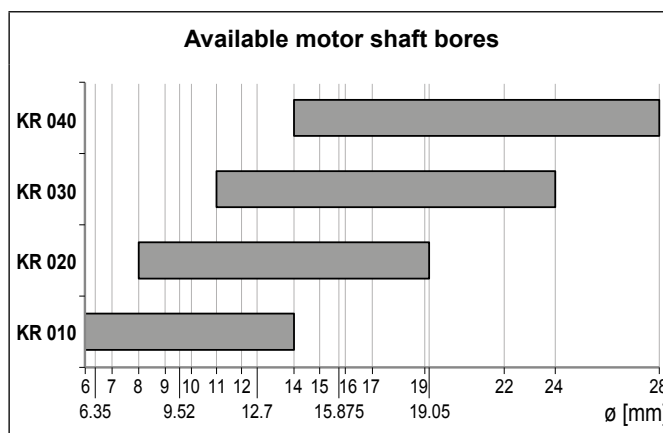

10.1 VERSIONS

Solid shaft

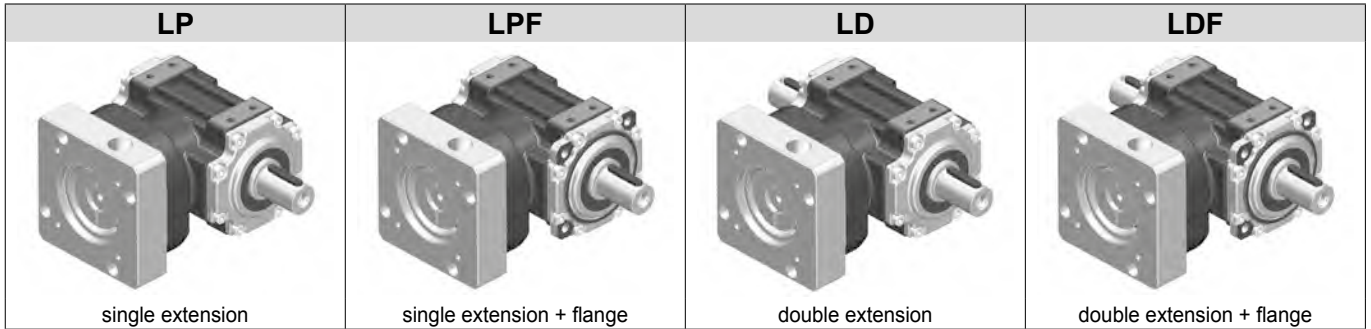

Hollow shaft

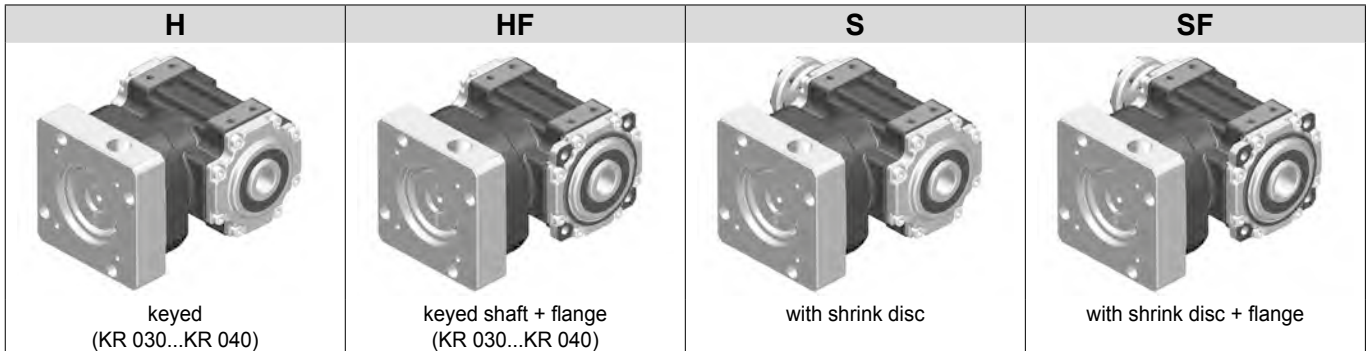

10.2 MOUNTING POSITIONS

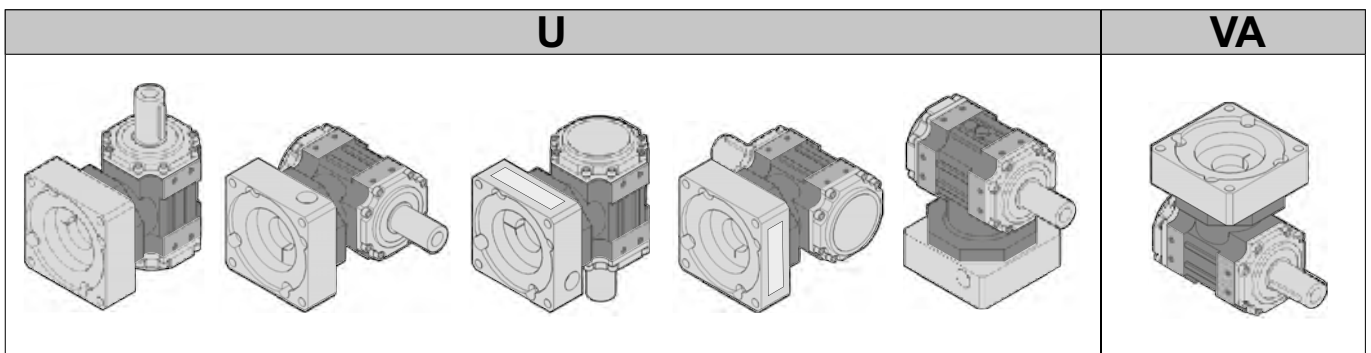

10.3 COORDINATED SHAFT ROTATION

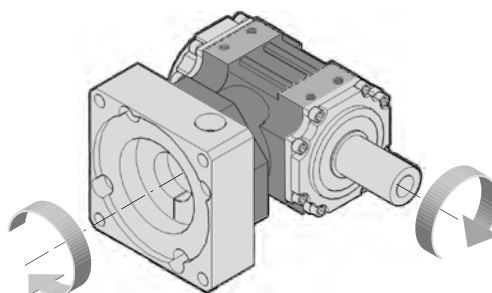

10.4 ORDERING CODE

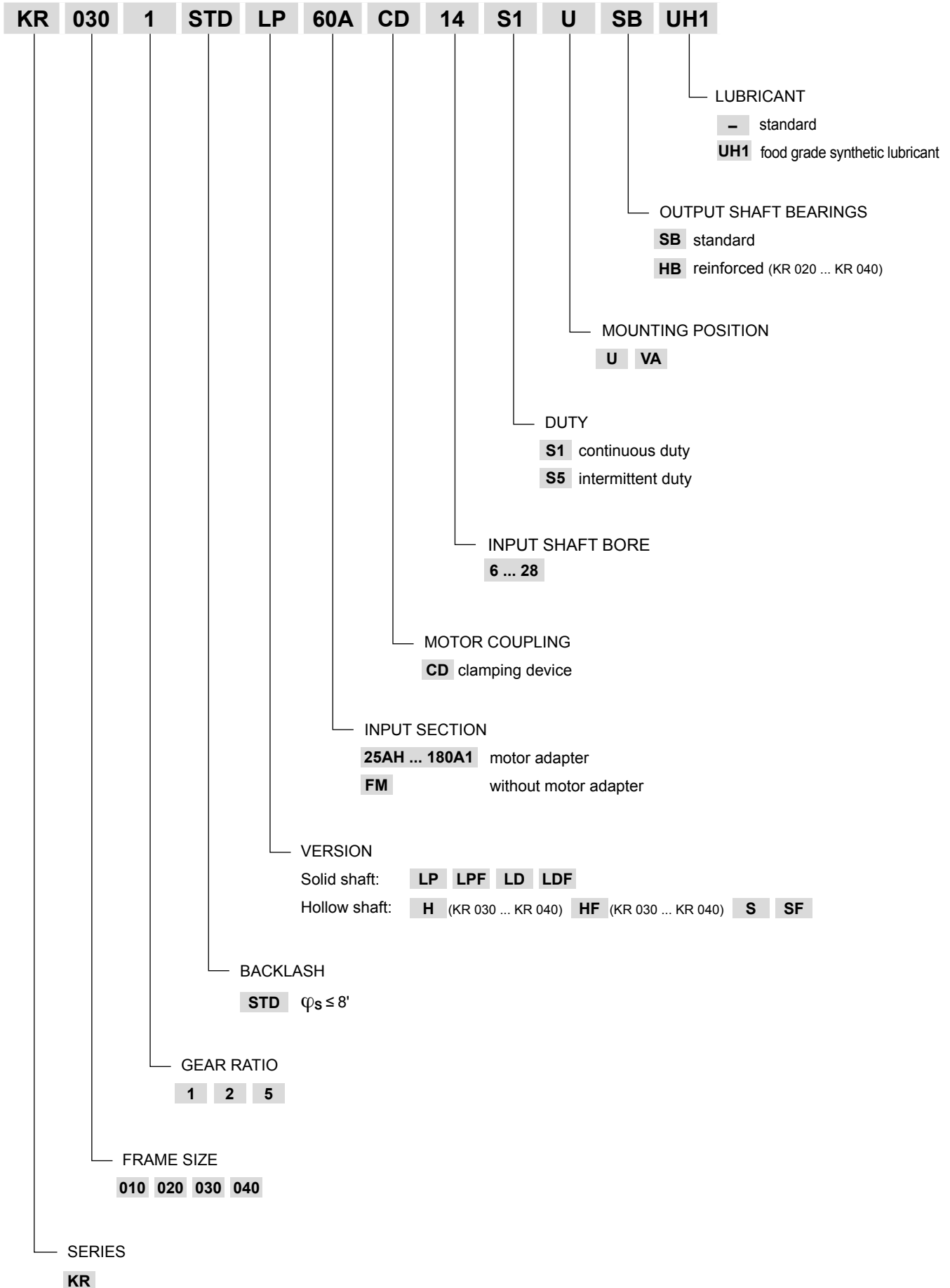

KR

10.5 TECHNICAL SPECIFICATIONS

KR 010								
	M_{n2} [Nm]	M_{a2} [Nm]	M_{p2} [Nm]	C_t [$\frac{Nm}{arcmin}$]	n_1 [min ⁻¹]	$n_{1 max}$ [min ⁻¹]	φ_s [arcmin]	η %
i = 1	10	14	20	0.5	2000	4000		
i = 2	7	10	15	0.4	2500	5000	8'	97
i = 5	3	4	6	0.2	3000	5000		

KR 020								
	M_{n2} [Nm]	M_{a2} [Nm]	M_{p2} [Nm]	C_t [$\frac{Nm}{arcmin}$]	n_1 [min ⁻¹]	$n_{1 max}$ [min ⁻¹]	φ_s [arcmin]	η %
i = 1	24	35	50	1.4	2000	4000		
i = 2	15	21	30	1.1	2500	5000	8'	97
i = 5	10	13	20	0.7	3000	5000		

KR 030								
	M_{n2} [Nm]	M_{a2} [Nm]	M_{p2} [Nm]	C_t [$\frac{Nm}{arcmin}$]	n_1 [min ⁻¹]	$n_{1 max}$ [min ⁻¹]	φ_s [arcmin]	η %
i = 1	55	75	110	4	1500	3500		
i = 2	37	52	75	3	2000	4500	8'	97
i = 5	22	29	45	2	2800	4500		

KR 040								
	M_{n2} [Nm]	M_{a2} [Nm]	M_{p2} [Nm]	C_t [$\frac{Nm}{arcmin}$]	n_1 [min ⁻¹]	$n_{1 max}$ [min ⁻¹]	φ_s [arcmin]	η %
i = 1	120	170	240	11	1500	3500		
i = 2	85	120	170	9	2000	4500	8'	97
i = 5	45	60	90	5	2500	4500		

Stiffness value is referred to LP version

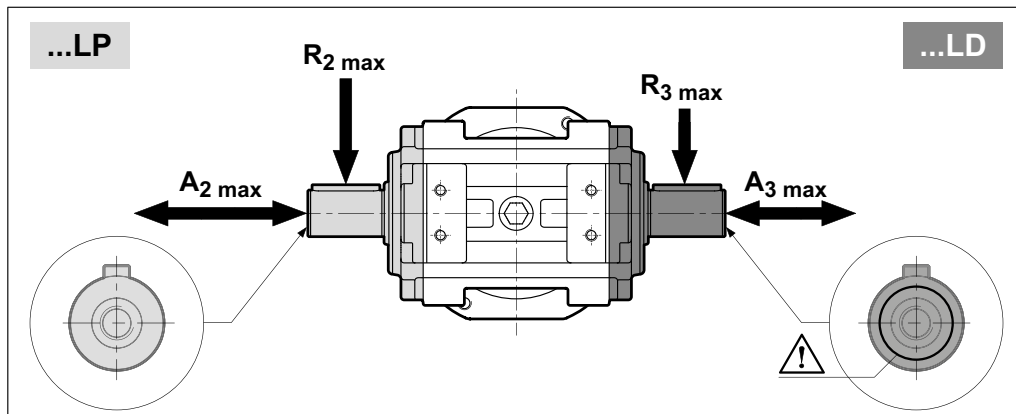





		$R_{2 max}$ [N]	$A_{2 max}$ [N]	$A_{2' max}$ [N]	$R_{3 max}$ [N]	$A_{3 max}$ [N]	$A_{3' max}$ [N]
KR 010	SB	1000	—	200	500	—	100
	HB	1500	—	300	750	—	150
KR 020	SB	3000	1500	600	3000	1500	600
	HB	4000	2000	800	4000	2000	800
KR 030	SB	2000	—	400	1000	—	200
	HB	4000	2000	800	4000	2000	800
KR 040	SB	3000	—	600	1500	—	300
	HB	5500	2750	1100	5500	2750	1100

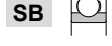

10.6 MASS MOMENT OF INERTIA

10.6.1 KR 010...KR 040 with standard ball bearings - SB

KR 010			
		J_G [kgcm ²]	
			
		$6 \leq D \leq 9.52$	$10 \leq D \leq 14$
i = 1	S, SF	0.52	0.52
	LP, LPF	0.38	0.38
	LD, LDF	0.39	0.39
i = 2	S, SF	0.27	0.29
	LP, LPF	0.24	0.25
	LD, LDF	0.24	0.25
i = 5	S, SF	0.20	0.21
	LP, LPF	0.19	0.21
	LD, LDF	0.19	0.21

KR 020			
		J_G [kgcm ²]	
			
		$8 \leq D \leq 12.7$	$14 \leq D \leq 19.05$
i = 1	S, SF	1.61	1.80
	LP, LPF	1.34	1.52
	LD, LDF	1.37	1.55
i = 2	S, SF	0.86	1.05
	LP, LPF	0.80	0.98
	LD, LDF	0.80	0.99
i = 5	S, SF	0.66	0.84
	LP, LPF	0.64	0.83
	LD, LDF	0.65	0.83

KR 030				
		J_G [kgcm ²]		
				
		$11 \leq D \leq 12.7$	$14 \leq D \leq 19$	$22 \leq D \leq 24$
i = 1	H, HF	4.37	4.45	4.64
	S, SF	5.00	5.08	5.27
	LP, LPF	4.70	4.78	4.97
	LD, LDF	4.63	4.71	4.90
i = 2	H, HF	2.04	2.12	2.31
	S, SF	2.20	2.28	2.47
	LP, LPF	2.12	2.20	2.39
	LD, LDF	2.11	2.19	2.37
i = 5	H, HF	1.47	1.55	1.74
	S, SF	1.50	1.57	1.76
	LP, LPF	1.48	1.56	1.75
	LD, LDF	1.48	1.56	1.75

KR 040				
		J_G [kgcm ²]		
				
		$14 \leq D \leq 19$	$22 \leq D \leq 24$	D = 28
i = 1	H, HF	17.19	17.37	17.77
	S, SF	20.46	20.65	21.05
	LP, LPF	18.21	18.40	18.80
	LD, LDF	18.90	19.08	19.48
i = 2	H, HF	4.47	4.65	5.06
	S, SF	5.29	5.47	5.87
	LP, LPF	4.73	4.91	5.31
	LD, LDF	4.90	5.08	5.48
i = 5	H, HF	5.23	5.42	5.82
	S, SF	5.36	5.55	5.95
	LP, LPF	5.27	5.46	5.86
	LD, LDF	5.30	5.49	5.89

10.6.2 KR 020...KR 040 with taper roller bearings - HB

KR 020			
		J _G [kgcm ²]	
		D	
HB 		8 ≤ D ≤ 12.7	14 ≤ D ≤ 19.05
i = 1	S, SF	1.87	2.06
	LP, LPF	1.60	1.78
	LD, LDF	1.62	1.81
i = 2	S, SF	0.93	1.12
	LP, LPF	0.86	1.05
	LD, LDF	0.87	1.05
i = 5	S, SF	0.67	0.85
	LP, LPF	0.66	0.84
	LD, LDF	0.66	0.84

KR 030				
		J _G [kgcm ²]		
		D		
HB 		11 ≤ D ≤ 12.7	14 ≤ D ≤ 19	22 ≤ D ≤ 24
i = 1	H, HF	5.48	5.56	5.75
	S, SF	6.11	6.19	6.38
	LP, LPF	5.81	5.89	6.08
	LD, LDF	5.74	5.82	6.01
i = 2	H, HF	2.92	3.00	3.19
	S, SF	3.08	3.16	3.35
	LP, LPF	3.01	3.09	3.27
	LD, LDF	2.99	3.07	3.26
i = 5	H, HF	1.51	1.59	1.78
	S, SF	1.54	1.62	1.81
	LP, LPF	1.53	1.61	1.80
	LD, LDF	1.53	1.60	1.79

KR 040				
		J _G [kgcm ²]		
		D		
HB 		14 ≤ D ≤ 19	22 ≤ D ≤ 24	D = 28
i = 1	H, HF	18.82	19.01	19.41
	S, SF	22.10	22.28	22.69
	LP, LPF	19.85	20.04	20.44
	LD, LDF	20.53	20.72	21.12
i = 2	H, HF	4.88	5.06	5.47
	S, SF	5.70	6.28	6.28
	LP, LPF	5.13	5.72	5.72
	LD, LDF	5.31	5.89	5.89
i = 5	H, HF	5.30	5.48	5.89
	S, SF	5.43	6.02	6.02
	LP, LPF	5.34	5.93	5.93
	LD, LDF	5.37	5.95	5.95

10.7 DIMENSIONS

KR 010

25AH ... 80A

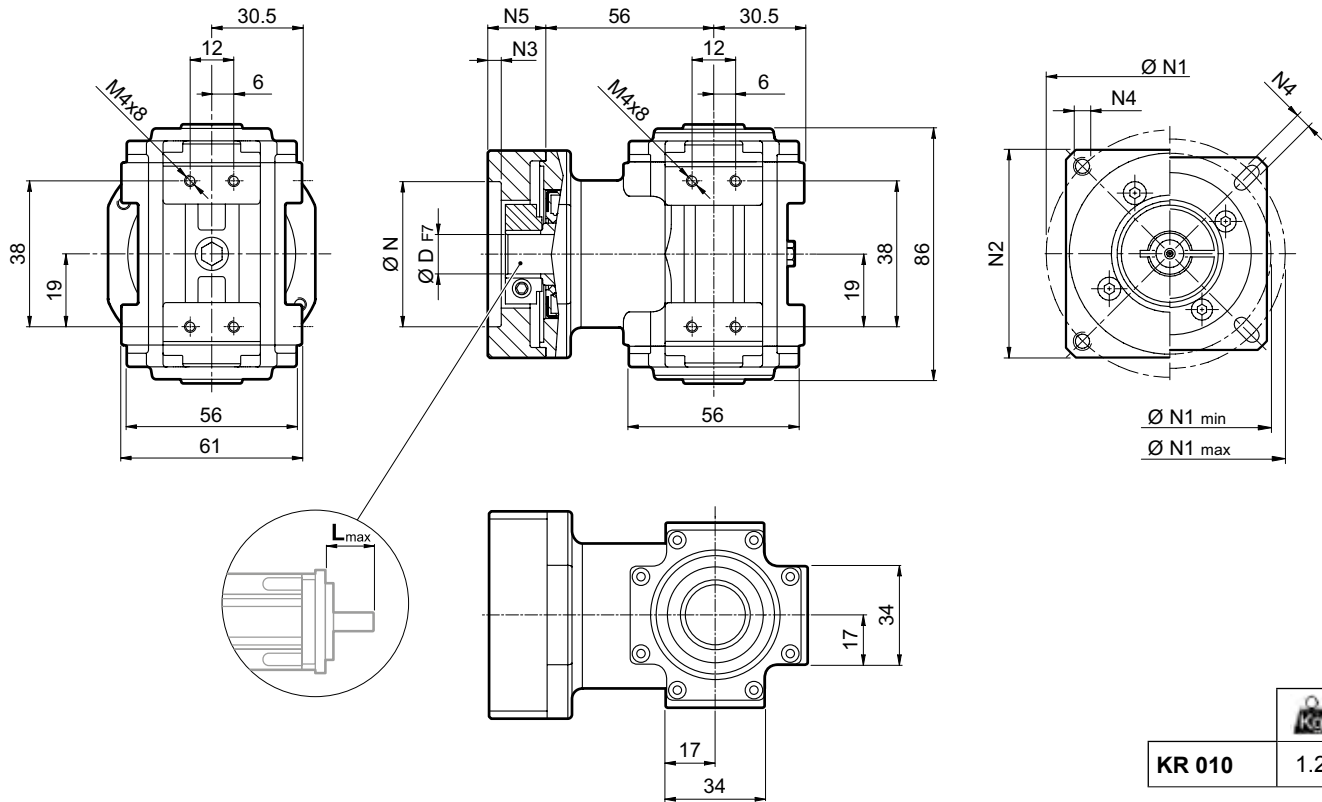

KR 010	1.2
--------	-----

	D	N	N1		N2	N3	N4	N5	L _{max}
			min	max					
25AH	6 6.35 7 8 9 9.52 - - - - -	25	39	56					
26AH	6 6.35 7 8 9 9.52 - - - - -	26	39	56					
28AH	6 6.35 7 8 9 9.52 - - - - -	28	39	56					
30AH	6 6.35 7 8 9 9.52 - - - - -	30	39	56					
32AH	6 6.35 7 8 9 9.52 - - - - -	32	39	56	65	3.5	4.5	25	25
34AH	6 6.35 7 8 9 9.52 - - - - -	34	40	56					
36AH	6 6.35 7 8 9 9.52 - - - - -	36	42	56					
39AH	6 6.35 7 8 9 9.52 - - - - -	39	45	56					
40AH	6 6.35 7 8 9 9.52 - - - - -	40	46	56					
38B	6 6.35 7 8 9 9.52 10 11 12 12.7 -	38.1	66.6		60	3	M4x10	18	25
40B	6 6.35 7 8 9 9.52 10 11 12 12.7 -	40	63		60	3	M4x10	18	25
50A	6 6.35 7 8 9 9.52 10 11 12 12.7 -	50	60		60	3	M4x10	18	25
50B	6 6.35 7 8 9 9.52 10 11 12 12.7 14	50	65		60	3	M5x12	23	30
50BH	6 6.35 7 8 9 9.52 10 11 12 12.7 14	50	65		65	3	5.5	25	32
50C	6 6.35 7 8 9 9.52 10 11 12 12.7 14	50	70		60	3	M4x10	23	30
55MH	6 6.35 7 8 9 9.52 10 11 12 12.7 -	55	80		65	2	5.5	16	23
60A	6 6.35 7 8 9 9.52 10 11 12 12.7 -	60	75		63	3	M5x12	18	25
60A1	6 6.35 7 8 9 9.52 10 11 12 12.7 14	60	75		63	3	M5x12	23	30
60B	6 6.35 7 8 9 9.52 10 11 12 12.7 14	60	85		75	3	M5x12	23	30
60C	6 6.35 7 8 9 9.52 10 11 12 12.7 14	60	90		75	3	M5x12	23	30
70A	6 6.35 7 8 9 9.52 10 11 12 12.7 14	70	85		75	3	M6x15	23	30
70B	6 6.35 7 8 9 9.52 10 11 12 12.7 14	70	90		75	3	M5x12	23	30
73A	6 6.35 7 8 9 9.52 10 11 12 12.7 14	73	98.4		85	3	M5x12	25	32
80A	6 6.35 7 8 9 9.52 10 11 12 12.7 14	80	100		85	3	M6x15	23	30

Please contact us for other motor adapters and input shaft bore.

KR 010

KR 010... S

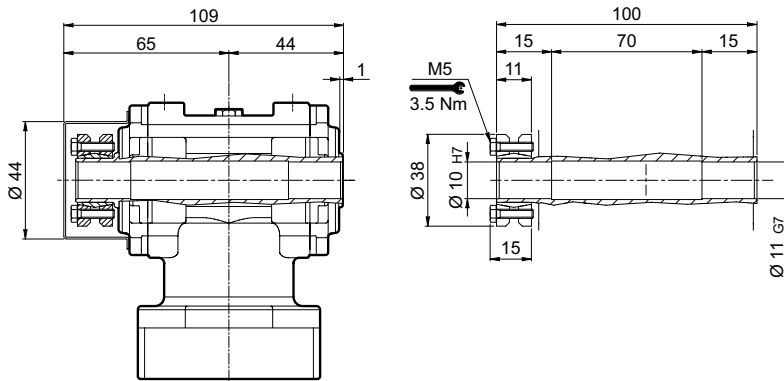

KR 010... SF

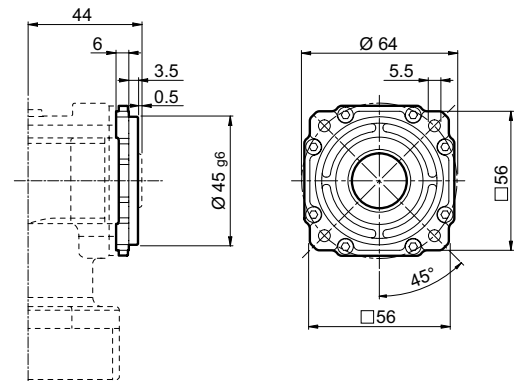

KR 010... LP

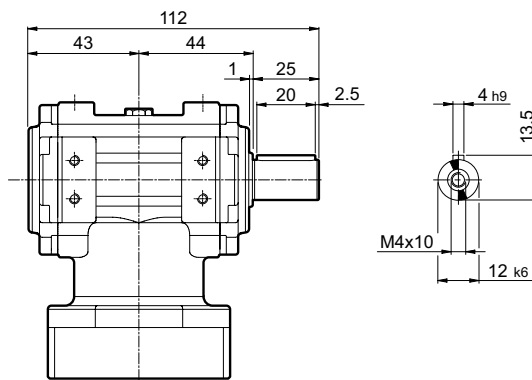

KR 010... LPF

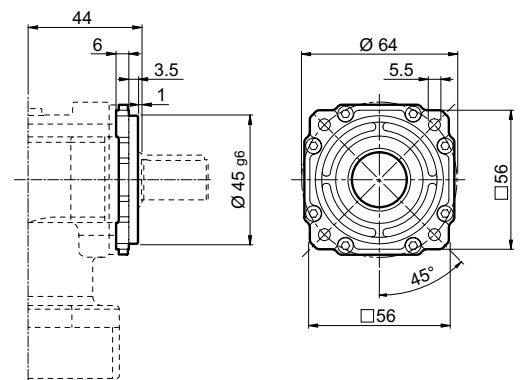

KR 010... LD

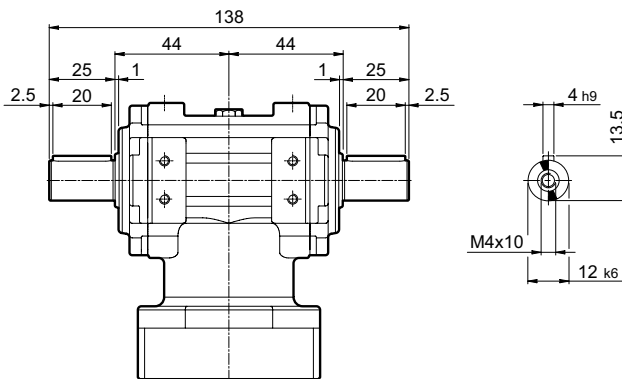

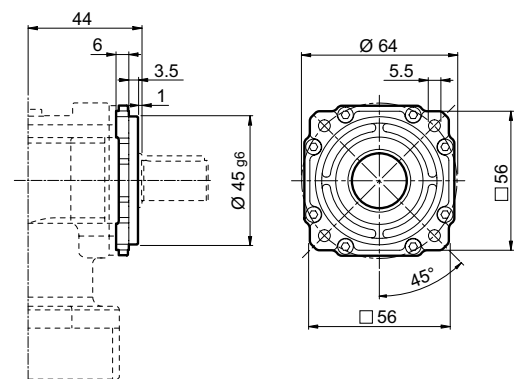

KR 010... LDF

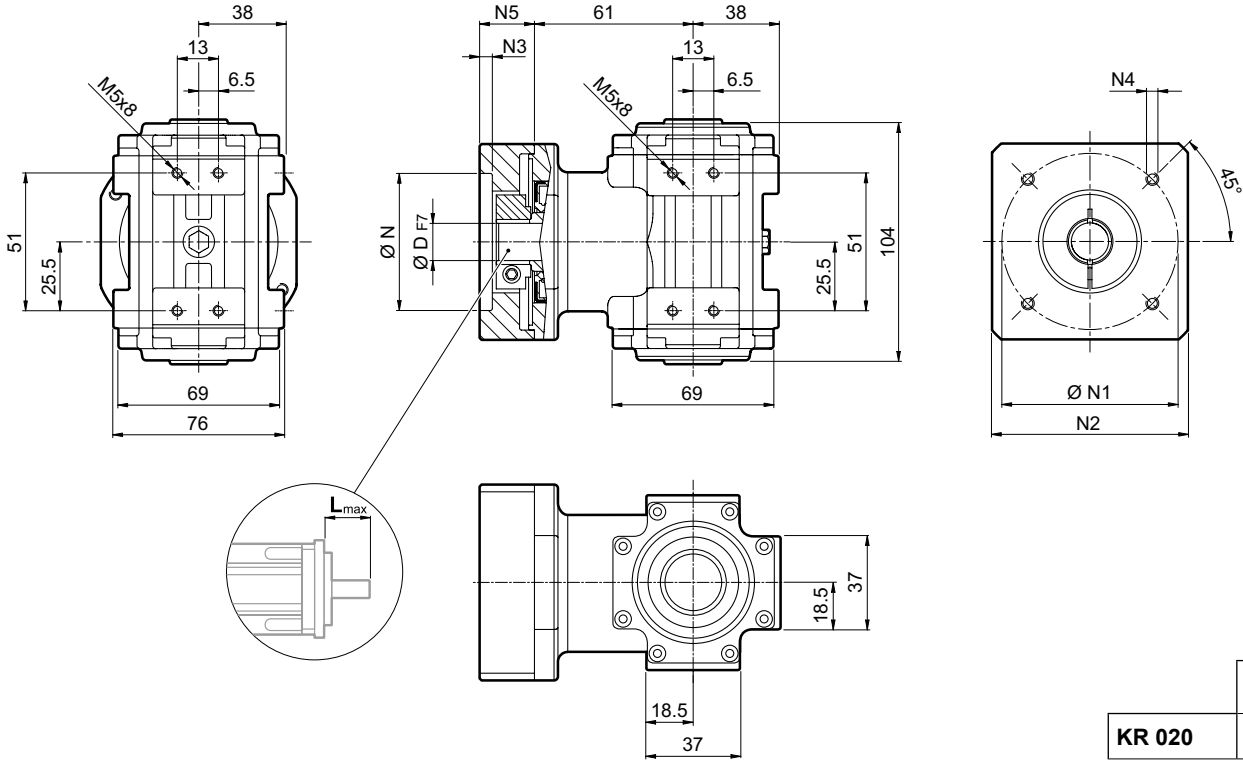

KR 020

40B1 ... 110B1

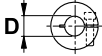

	KR 020	2.6
---	---------------	-----

												N	N1	N2	N3	N4	N5	L _{max}	
40B1	8	9	9.52	11	12	12.7	14	-	-	-	-	-	40	63	80	4	M4x10	34	40
45A	8	9	9.52	11	12	12.7	-	-	-	-	-	-	45	63	80	4	M4x10	34	40
50B1	8	9	9.52	11	12	12.7	14	-	-	-	-	-	50	65	80	4	M5x16	34	40
50BH1	8	9	9.52	11	12	12.7	14	-	-	-	-	-	50	65	80	4	5.5	34	40
50C1	8	9	9.52	11	12	12.7	14	-	-	-	-	-	50	70	80	4	M4x10	34	40
50D	8	9	9.52	11	12	12.7	14	-	-	-	-	-	50	95	80	4	M6x10	34	40
55A	8	9	9.52	11	12	12.7	14	15.875	16	17	19	19.05	55.5	125.7	105	4	M6x16	34	40
60A2	8	9	9.52	11	12	12.7	14	-	-	-	-	-	60	75	80	4	M5x16	34	40
60AH2	8	9	9.52	11	12	12.7	14	-	-	-	-	-	60	75	90	4	5.5	34	40
60B1	8	9	9.52	11	12	12.7	14	15.875	16	-	-	-	60	85	80	4	M5x16	34	40
60C1	8	9	9.52	11	12	12.7	14	15.875	16	-	-	-	60	90	80	4	M5x16	34	40
70A1	8	9	9.52	11	12	12.7	14	15.875	16	17	19	19.05	70	85	80	4	M6x20	34	40
70AH1	8	9	9.52	11	12	12.7	14	15.875	16	17	19	19.05	70	85	90	4	6.5	34	40
70B1	8	9	9.52	11	12	12.7	14	15.875	16	17	19	19.05	70	90	80	4	M5x16	34	40
73A1	8	9	9.52	11	12	12.7	14	-	-	-	-	-	73	98.4	85	4	M5x16	34	40
80A1	8	9	9.52	11	12	12.7	14	15.875	16	17	19	19.05	80	100	90	4	M6x16	34	40
95A	8	9	9.52	11	12	12.7	14	15.875	16	17	19	19.05	95	115	100	4	M8x20	34	40
95B	8	9	9.52	11	12	12.7	14	15.875	16	17	19	19.05	95	130	115	4	M8x20	34	40
110A	8	9	9.52	11	12	12.7	14	15.875	16	17	19	19.05	110	130	115	4	M8x20	34	40
110B	8	9	9.52	11	12	12.7	14	15.875	16	17	19	19.05	110	145	120	6.5	M8x20	44	50
110B1	8	9	9.52	11	12	12.7	14	15.875	16	17	19	19.05	110	145	120	6.5	M8x20	54	60

Please contact us for other motor adapters and input shaft bore.

KR 020

KR 020... S

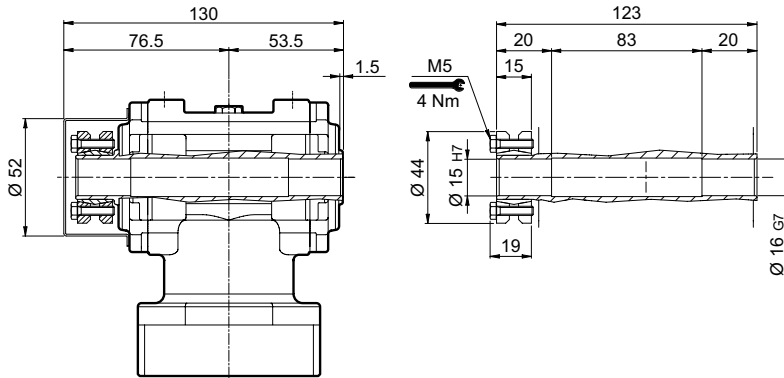

KR 020... SF

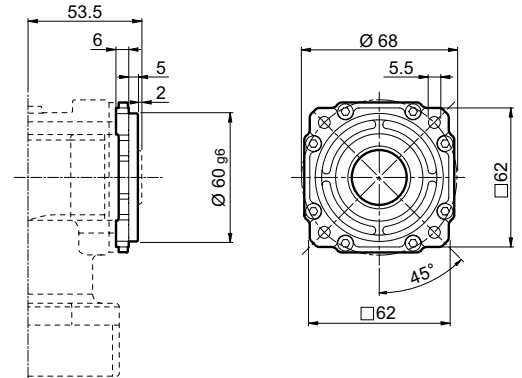

KR 020... LP

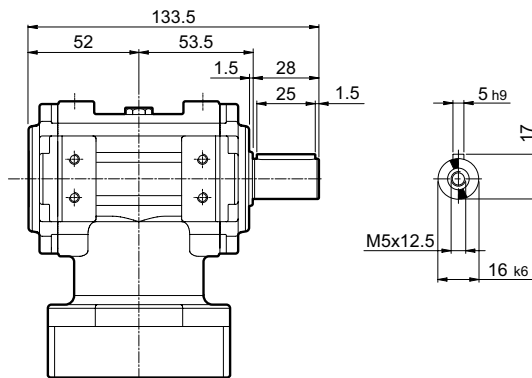

KR 020... LPF

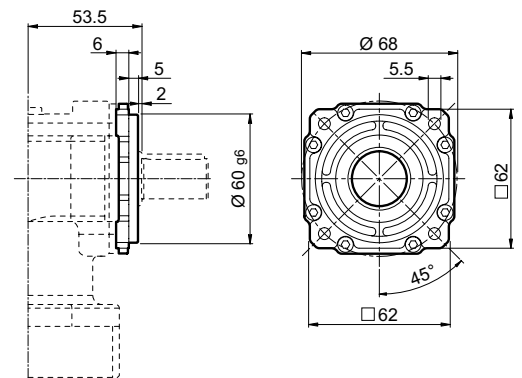

KR 020... LD

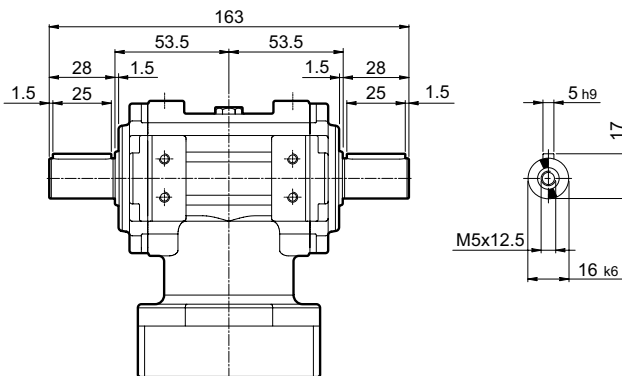

KR 020... LDF

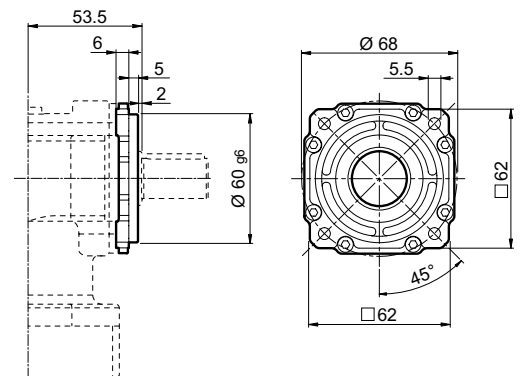

KR 030

50D ... 130A1

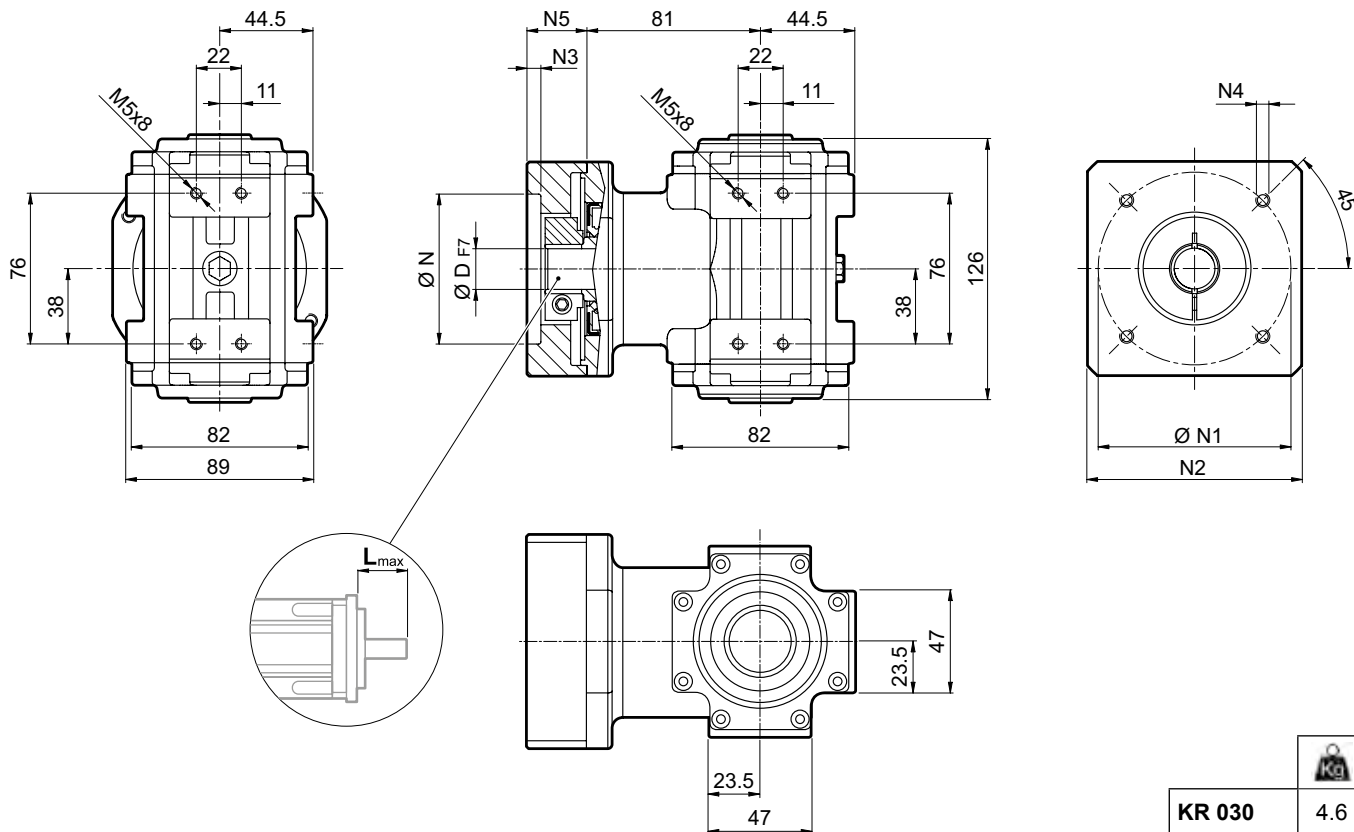

KR 030

4.6

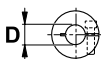
											N	N1	N2	N3	N4	N5	L _{max}
	11	12	12.7	14	15	15.875	16	19	—	—							
50D	11	12	12.7	14	15	15.875	16	19	—	—	50	95	100	5	M6x14	28	40
55A	11	12	12.7	14	15	15.875	16	19	—	—	55.5	125.7	105	5	M6x16	28	40
60A2	11	12	12.7	14	15	15.875	16	19	—	—	60	75	100	5	M5x14	28	40
60AH2	11	12	12.7	14	15	15.875	16	19	—	—	60	75	100	5	6.5	33	40
60B1	11	12	12.7	14	15	15.875	16	19	—	—	60	85	100	6.5	M5x14	28	40
70A1	11	12	12.7	14	15	15.875	16	19	—	—	70	85	100	5	M6x14	28	40
70AH1	11	12	12.7	14	15	15.875	16	19	—	—	70	85	100	5	6	33	40
70B1	11	12	12.7	14	15	15.875	16	19	—	—	70	90	100	5	M5x12	28	40
80A1	11	12	12.7	14	15	15.875	16	19	—	—	80	100	100	5	M6x16	28	40
80AH1	11	12	12.7	14	15	15.875	16	19	—	—	80	100	100	5	6.5	28	40
95A	11	12	12.7	14	15	15.875	16	19	—	—	95	115	100	5	M8x18	28	40
95A1	11	12	12.7	14	15	15.875	16	19	22	24	95	115	100	5	M8x18	38	50
95B	11	12	12.7	14	15	15.875	16	19	—	—	95	130	115	5	M8x18	28	40
110A	11	12	12.7	14	15	15.875	16	19	—	—	110	130	115	5	M8x18	28	40
110A1	11	12	12.7	14	15	15.875	16	19	22	24	110	130	115	6.5	M8x20	38	50
110B	11	12	12.7	14	15	15.875	16	19	22	24	110	145	120	6.5	M8x20	38	50
110B1	11	12	12.7	14	15	15.875	16	19	22	24	110	145	120	6.5	M8x20	48	60
130A	11	12	12.7	14	15	15.875	16	19	22	24	130	165	140	6.5	M10x20	38	50
130A1	11	12	12.7	14	15	15.875	16	19	22	24	130	165	140	6.5	M10x25	48	60

Please contact us for other motor adapters and input shaft bore.

KR 030

KR 030... H

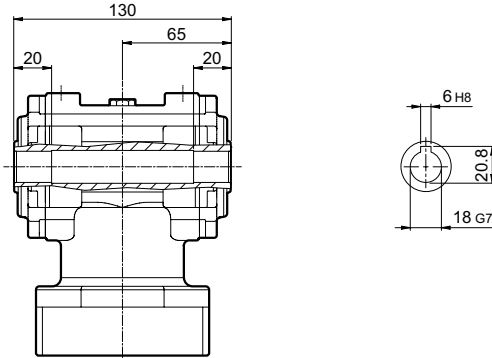

KR 030... HF

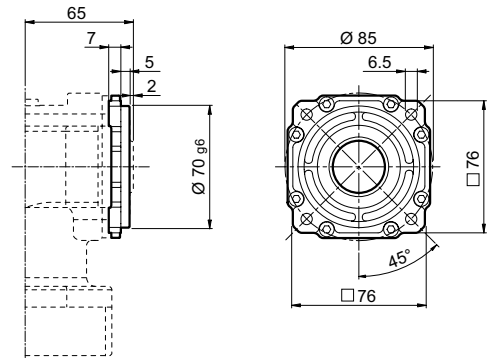

KR 030... S

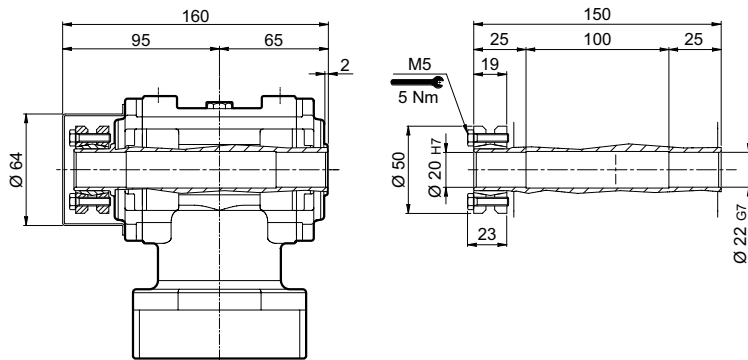

KR 030... SF

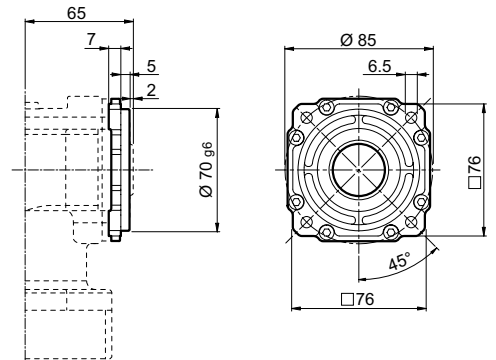

KR 030... LP

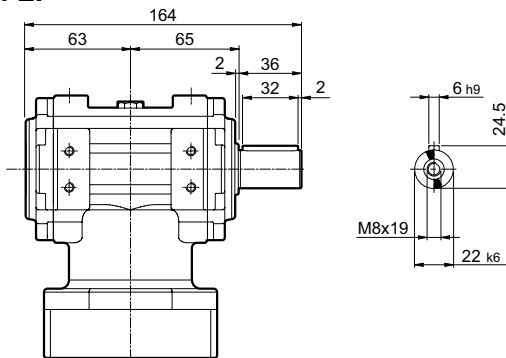

KR 030... LPF

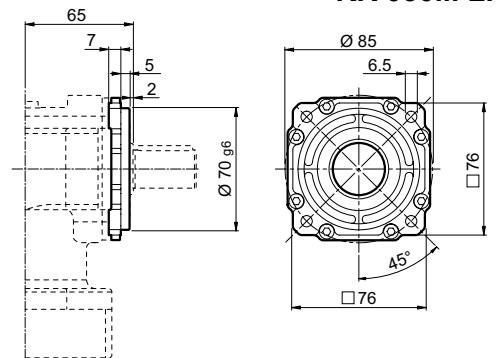

KR 030... LD

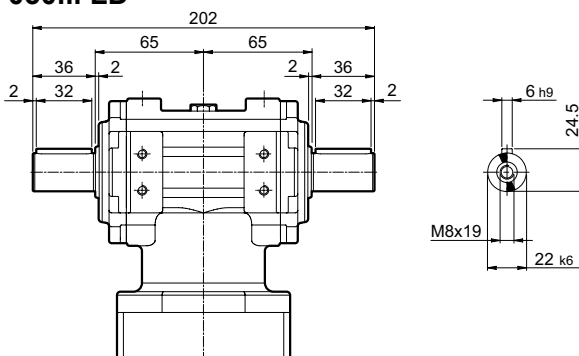

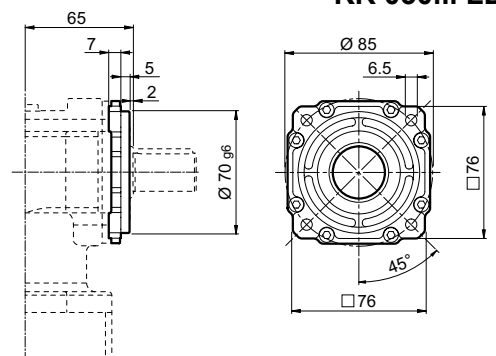

KR 030... LDF

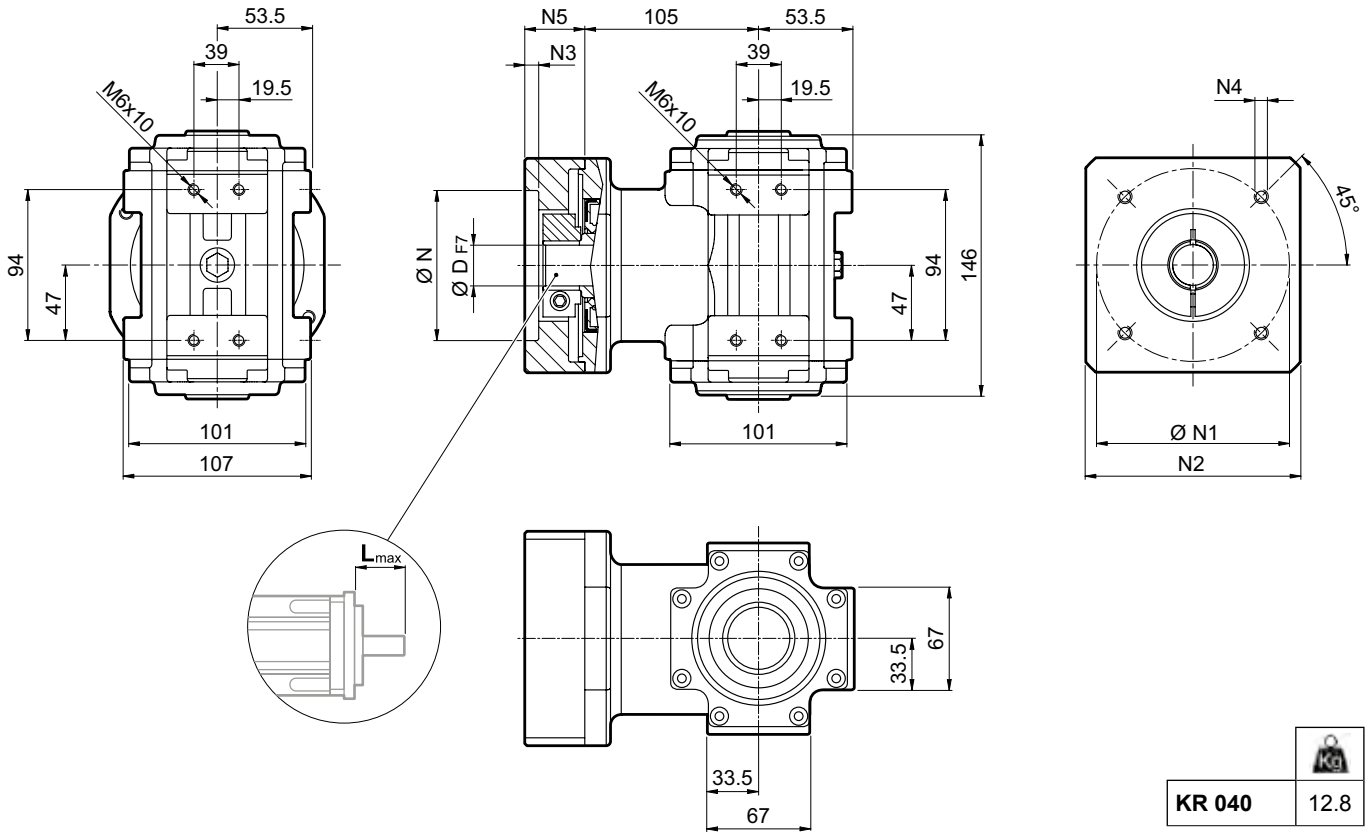

KR 040

55A1 ... 180A1

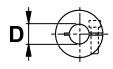

	KR 040	12.8
---	---------------	------

								N	N1	N2	N3	N4	N5	L _{max}
55A1	14	15.875	16	19	-	-	-	55.5	125.7	130	4	M6x15	39.5	50
80A2	14	15.875	16	19	-	-	-	80	100	130	4	M6x15	39.5	50
95A1	14	15.875	16	19	22	24	-	95	115	130	4	M8x20	39.5	50
110A1	14	15.875	16	19	22	24	-	110	130	130	4	M8x20	39.5	50
110B1	14	15.875	16	19	22	24	-	110	145	130	6.5	M8x20	49.5	60
114A	14	15.875	16	19	22	24	28	114.3	200	170	5.5	M12x25	69.5	80
130A	14	15.875	16	19	22	24	-	130	165	140	4	M10x20	39.5	50
130A1	14	15.875	16	19	22	24	28	130	165	140	4	M10x20	49.5	60
180A	14	15.875	16	19	22	24	28	180	215	190	5.5	M14x25	49.5	60
180A1	14	15.875	16	19	22	24	28	180	215	190	5.5	M14x25	69.5	80

Please contact us for other motor adapters and input shaft bore.

KR 040

KR 040... H

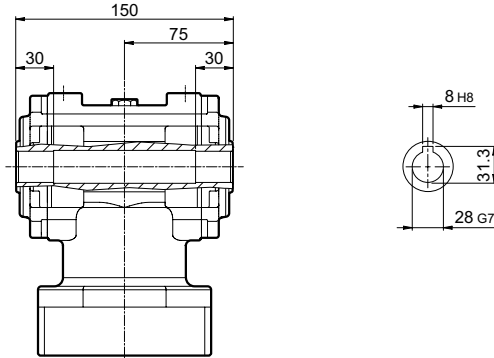

KR 040... HF

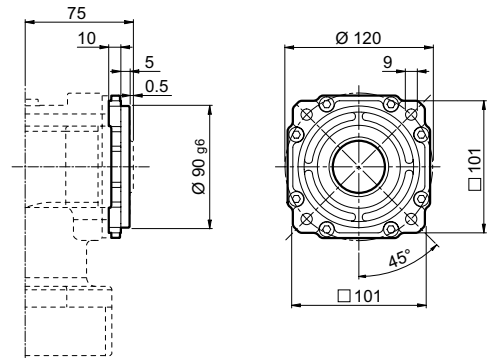

KR 040... S

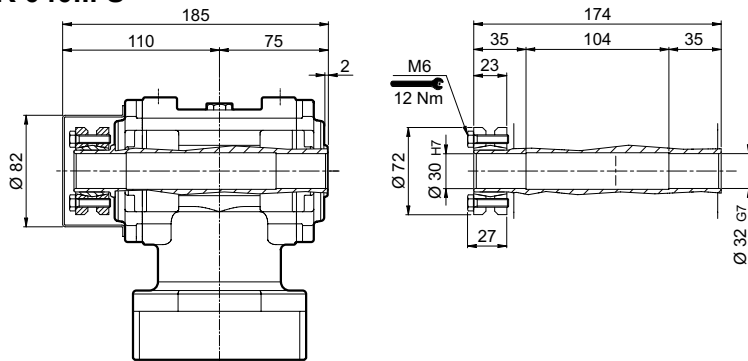

KR 040... SF

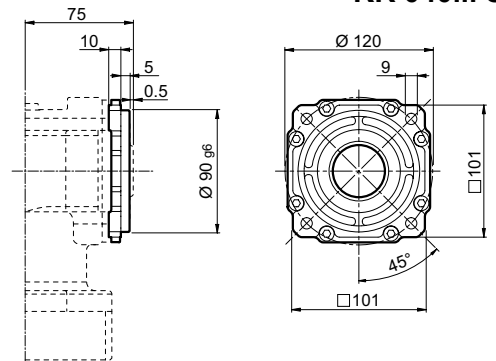

KR 040... LP

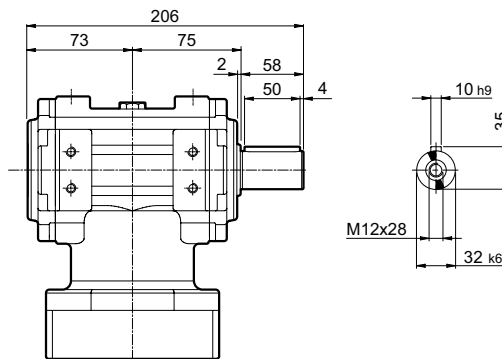

KR 040... LPF

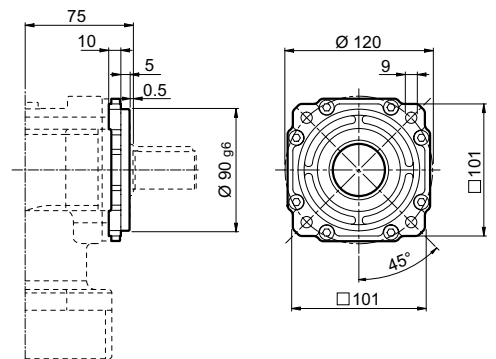

KR 040... LD

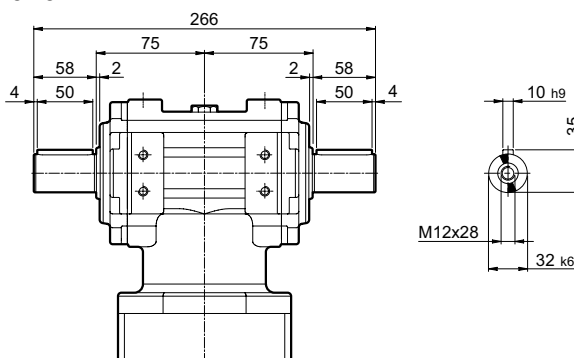

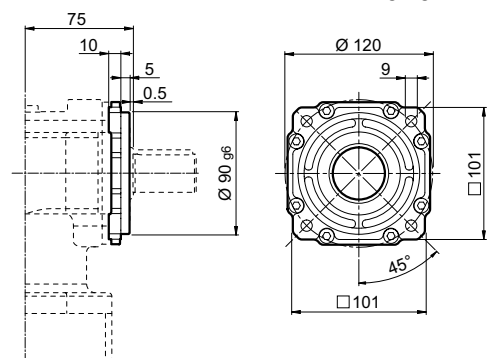

KR 040... LDF

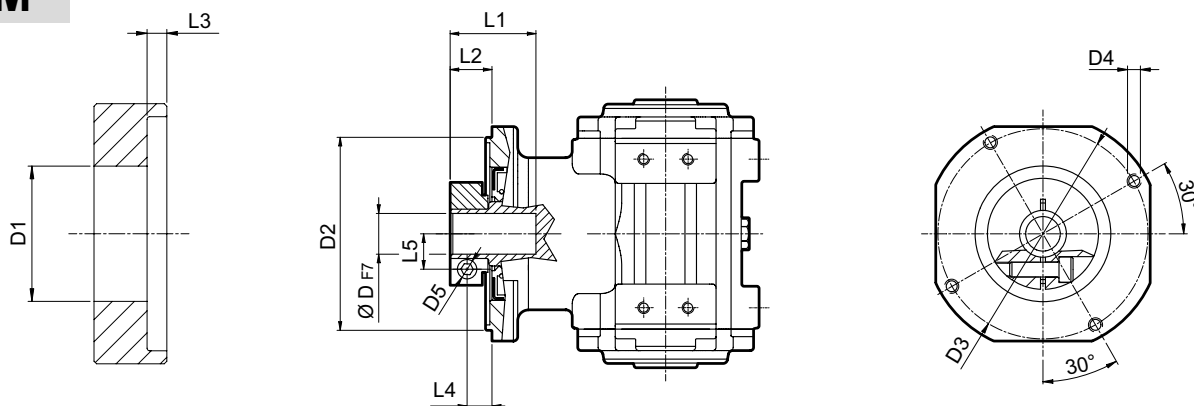

10.7.1 GEARBOX WITHOUT MOTOR ADAPTER

FM

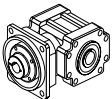
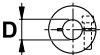



		D1	D2	D3	D4	D5	L1	L2	L3	L4	L5	
KR 010	6 6.35 7	32.5	50	42.5	M4x8	M4	28	13.5	3	8.5	8	1.0
	8 9 9.52 10	32.5	50	42.5	M4x8	M4	28	13.5	3	8.5	9	
	11 12 12.7	35.5	50	42.5	M4x8	M4	23	13.5	3	8.5	11	
	14	35.5	50	42.5	M4x8	M4	25	15.5	3	8.9	11.5	
KR 020	8 9 9.52	38	68	76.5	M6x10	M6	36.3	26.3	9.5	18.8	10.5	2.0
	11 12 12.7	43	68	76.5	M6x10	M6	36.3	26.3	9.5	18.8	12.5	
	14 15.875 16 17	48	68	76.5	M6x10	M6	36.3	26.3	9.5	18.8	14.5	
	19 19.05	51	68	76.5	M6x10	M6	36.3	26.3	9.5	18.8	16.5	
KR 030	11 12 12.7	43	90	98	M6x15	M6	35	19.5	7.6	12.1	12.5	3.5
	14 15 15.875 16	48	90	98	M6x15	M6	35	19.5	7.6	12.1	14.5	
	19	51	90	98	M6x15	M6	35	19.5	7.6	12.1	16.5	
	22 24	56.5	90	98	M6x15	M6	37	21.5	7.6	12.1	19	
KR 040	14 15.875 16	48	113	125.5	M8x15	M6	46	27.5	6	20	14.5	10.0
	19	51	113	125.5	M8x15	M6	46	27.5	6	20	16.5	
	22 24	56.5	113	125.5	M8x15	M6	47.5	29	6	20	19	
	28	67	113	125.5	M8x15	M8	47.5	29	6	20	22.5	

10.7.2 MACHINE SHAFT

Pivot of driven equipment should be made from high grade alloy steel. Table below shows recommended dimensions for the Customer to consider when designing mating shaft. A device retaining the shaft axially is also recommended (not shown). The number and size of relative tapped holes at shaft end depend on application requirements.

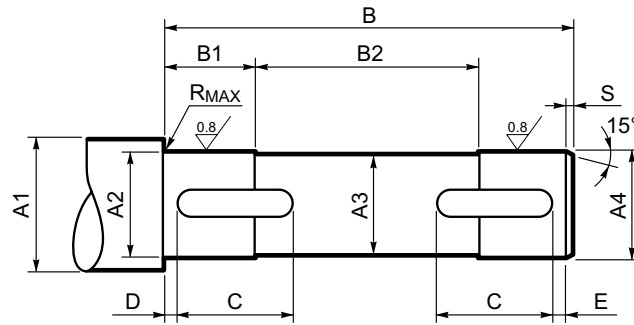
H

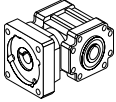

	A1	A2	A3	A4	B	B1	B2	C	D	E	R _{MAX}	 UNI 6604	S
KR 030	≥ 26	18 h7	17	18 h7	129	18	90	32	2	2	0.5	6x6x25 A	1
KR 040	≥ 36	28 h7	27	28 h7	149	28	90	50	2	2	0.5	8x7x35 A	

NB: The choice of driven shaft with a UNI 6604 key as described introduces increased backlash into the application compared to that achieved by a configuration with just the gearbox ($\psi_s \leq 8'$).

S

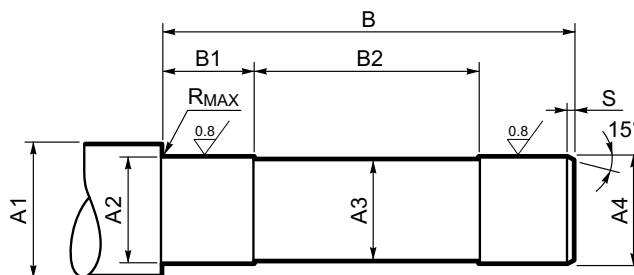

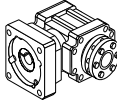
	A1	A2	A3	A4	B	B1	B2	R _{MAX}	S
KR 010	≥ 15	11 h7	9.5	10 h6	99	13	70	0.5	1
KR 020	≥ 20	16 h7	14.5	15 h6	122	18	83	0.2	
KR 030	≥ 30	22 h7	19.5	20 h6	149	23	100	0.5	
KR 040	≥ 40	32 h7	29.5	30 h6	173	33	104	0.5	

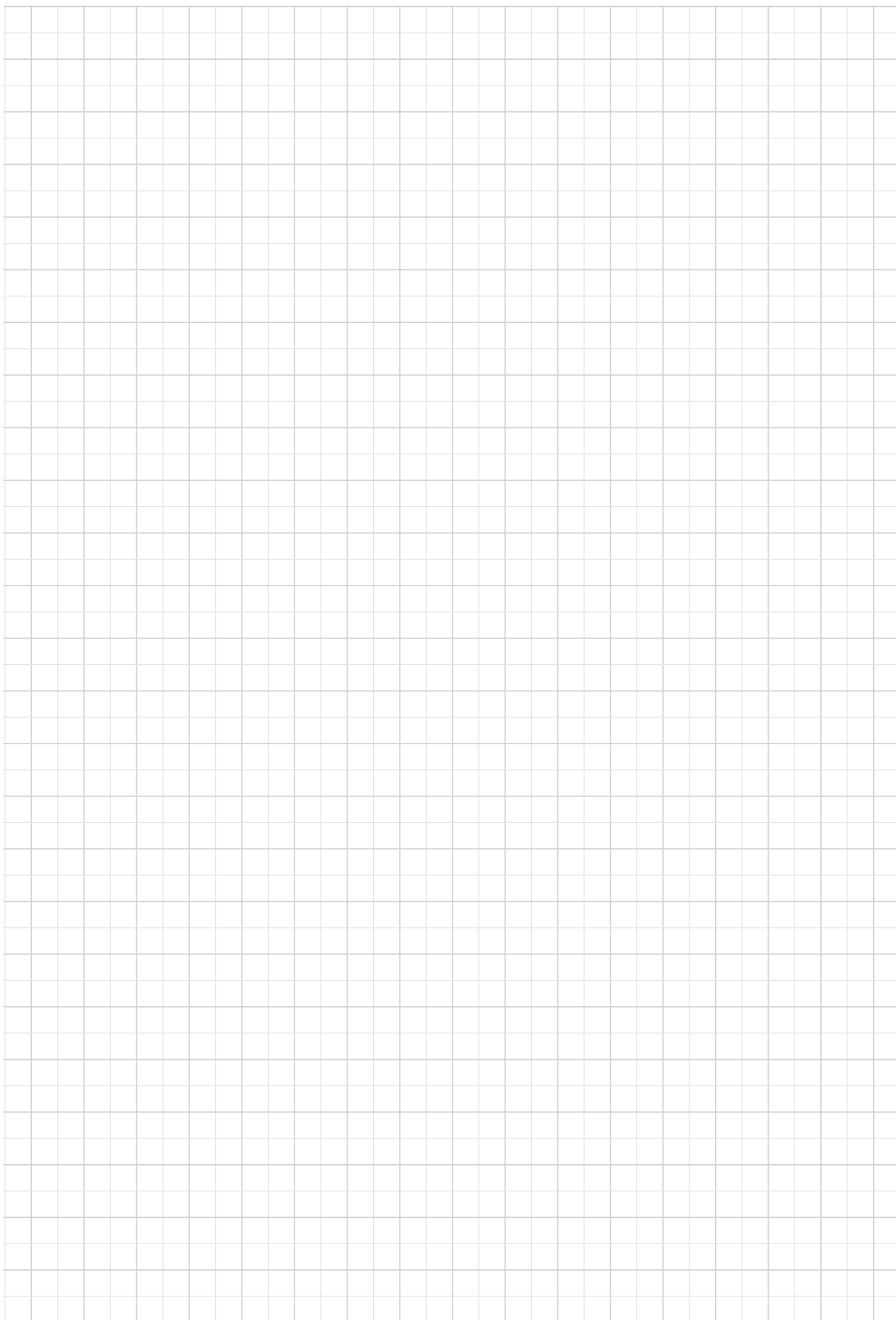

Leveringsprogramma



- Frequentieregelaars / Gelijkstroomregelaars
- Servobesturingen / PLC's
- Scada / adaptieve regelsystemen
- Pulsgevers / Encoders / Tacho's
- Industriële besturingscomponenten

Besturingen

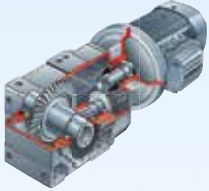

- Wormwielreductoren
- Tandwielreductoren
- Planetaire reductoren
- Servo reductoren
- Mobiele aandrijvingen

Reductoren



- Draaistroommotoren (met rem) / Wisselstroommotoren (met rem)
- Servomotoren (met rem) / Gelijkstroommotoren (met rem)
- ATEX / Drukvaste motoren (met rem)
- Trilmotoren
- Hydromotoren en remmen

Motoren



- Starre / Draaistijve koppelingen
- Flexibele / (Hoog)elastische koppelingen
- Aanloop / Schakelbare koppelingen
- Vrijloop / Veiligheidskoppelingen
- Remkoppelingcombinaties

Koppelingen



- Tandwiel overbrengingen
- Snaar overbrengingen
- Ketting overbrengingen
- Klembussen

Open aandrijvingen



- Lineaire aandrijvingen / Spindelaandrijvingen
- Remmen (Schijf / Blok / Hydraulisch / Pneumatisch)
- Afstandbedienkabels
- Universele lagers / Klaplagers / Spanassen
- Hydraulische ventielen en appendages

Componenten



- Lieren / Takels / Hijs- en heftoebehoren
- Heftafels / Tilhulpmiddelen
- Goederenliften / Huisliften
- Interne logistieke systemen
- Transport equipment

Transport



- Reparatie, Revisie en onderhoud van alle fabrikaten aandrijfcomponenten
- MRO (=Maintenance Repair Overhaul)
- Diagnostiek, preventief- en correctief onderhoud "On en off site"
- Wikkelen en balanceren van elektromotoren / generatoren
- Engineering en productie van speciale maatwerk aandrijvingen en refits
- Ontwerp en bouw van besturingsystemen en schakelkasten

Services

- Verkoop elektro-mechanische aandrijvingen (motoren, reductoren, lineaire aandrijvingen, componenten) en regelaars.
- Engineering en productie van speciale aandrijvingen.



- Engineering en productie van besturingsoplossingen en paneelbouw.
- Verkoop van frequentieregelaars, servoaandrijvingen en complete besturingen.



- Regionale verkoop elektro-mechanische aandrijvingen (motoren, reductoren, lineaire aandrijvingen, componenten) en regelaars.
- Specialist in servo-tandoverbrengingen en koppelingen.



- Regionale verkoop elektro-mechanische aandrijvingen en regelaars.
- Reparatie en revisie van alle fabrikaten aandrijfcomponenten.
- Maintenance Repair Overhaul
- Wikkelen en balanceren van elektromotoren.



- Maintenance Repair Overhaul
- Preventief en correctief onderhoud van aandrijvingen in productie-omgevingen.
- Revisie generatorsets.
- Specialist in ATEX onderhoud.
- Verkoop elektro-mechanische aandrijvingen en regelaars.



- Verkoop in België en Luxemburg van elektro-mechanische aandrijvingen (motoren, reductoren, lineaire aandrijvingen, componenten) en regelaars.
- Engineering en productie van speciale aandrijvingen.



ELSTO Drives

Loosterweg 7
 2215 TL Voorhout - NL
T +31(0)88 7865200
F +31(0)88 7865299
E drives@elsto.eu

ELSTO Controls

Carolus Clusiuslaan 1
 2215 RV Voorhout - NL
T +31(0)88 7865800
F +31(0)88 7865899
E controls@elsto.eu

ELSTO Noord

Gotenburgweg 60
 9723 TM Groningen - NL
T +31(0)88 7865500
F +31(0)88 7865599
E noord@elsto.eu

ELSTO Services

Copernicusstraat 9 C
 6003 DE Weert - NL
T +31(0)88 7865460
F +31(0)88 7865494
E services@elsto.eu

STOLK Services

Voltweg 20
 4631 SR Hoogerheide - NL
T +31(0)88 7865400
F +31(0)88 7865499
E info@stolkservices.nl

BOEKHOLT Transmissions

Postbus 56
 2160 Wommelgem (Antw.)
T +32(0)3 355 1110
F +32(0)3 355 1115
E info@boekholt.be